



Electric Tilting Bratt Pan

Specification	PRO 900 SERIES
E1SBE 50 AERO	V02965
E1SBE 50 AERO EL	V02973
E1SBE 75 AERO	V03015
E1SBE 75 AERO EL	V03013



INSTALLATION MANUAL

CHARVET

F-38850 – CHARAVINES Pro 900 EN ESB
Tel.: (33)-4-76-06-64-22
Fax: +33 (0) 4 76 55 78 75
Email: info@charvet.fr
Email: sav@charvet-sa.fr



ind. A - Created on: 09-10-2013
Updated on:
Code:

SUMMARY

<u>INSTALLATION MANUAL.....</u>	<u>1</u>
<u>1. INSTALLATION</u>	<u>3</u>
1.1. GENERAL POINTS	3
1.2. HANDLING - INSTALLATION	3
1.3. INSTALLATION	3
1.4. DATA PLATE	4
<u>2. POWER CONNECTION.....</u>	<u>4</u>
2.1. CHECKS BEFORE CONNECTING	4
2.2. CONNECTING THE APPLIANCE TO THE MAINS POWER SUPPLY.....	5
2.3. CHECKS AFTER CONNECTION	6
2.4. ADAPTING THE APPLIANCE TO THE VARIOUS GRID VOLTAGES	6
<u>3. WATER CONNECTION (V02973/V02965)</u>	<u>6</u>
3.1. REMOVING THE SOLENOID VALVE.....	7
3.2. CHECKS AFTER CONNECTION.....	8
<u>4. BASIC SPARE PARTS LIST.....</u>	<u>8</u>
<u>5. MAINTENANCE.</u>	<u>9</u>
5.1. CHANGING THE HEATING ELEMENT (TILTING BRATT PAN 50/75).....	9
<u>6. WIRING</u>	<u>10</u>

1. INSTALLATION

1.1. General points

The appliance must be installed in an adequately aerated room, equipped with an air extraction system, following standard procedure and conforming to the regulations in effect in the country of installation, and to the instructions contained in this manual.

The user's manual must be given to the user after installation.

1.2. Handling - Installation

It is imperative to leave the appliance on its wooden pallet during the handling process until the final installation.

Unpack and check the appliance for damage upon receipt.

In case of damage, mark delivery note immediately and accordingly (within 48 hours); notify the carrier by registered mail with acknowledgement of receipt. Notify your installer.

1.3. Installation

Special attention must be paid to the local fire prevention regulations of the organization concerned (see [Public Access Premises]).

The appliance must be installed under a suitable aspiration hood.

If the appliance is to be installed against a wall or partition, near a piece of furniture or decorative borders, it is advised that these are of a fireproof material.

If this is not the case, they must be protected by an approved fireproof, insulating material.

If in doubt of the fireproof construction of adjacent walls, the distance to combustible material should be no less than 10 cm.

Remove all plastic protection.

Install the appliance in the work place.

Warning



Fixed appliance:

- Check that the masonry plinth is well horizontally leveled.
- Level the appliance by adjusting the height of the feet until the working surface is level.

• Mobile appliance:

Install the castors (they are delivered in a box kept inside the appliance).

The castors with brakes must be locked when the appliance is being connected and during cooking.

Fix all independent half modules against the wall.

Any intervention or repair on an appliance must be undertaken by a qualified installer. The appliance shall be isolated from the electrical supply or shall be segregated (written procedures, physically) for the duration of the work.

When the appliance is ready for use, ensure the users know how to use it properly.
(Please see the User's Manual.)

Warranty: The warranty is discussed in our sale contract.

This warranty does not cover damage due to faulty installation, misuse or inadequate maintenance.

1.4. **Data plate**

Each appliance has its own data plate. Transfer all the information written on the data plate to the last page of the user's manual.

This will facilitate the communications between you and your client for better service.

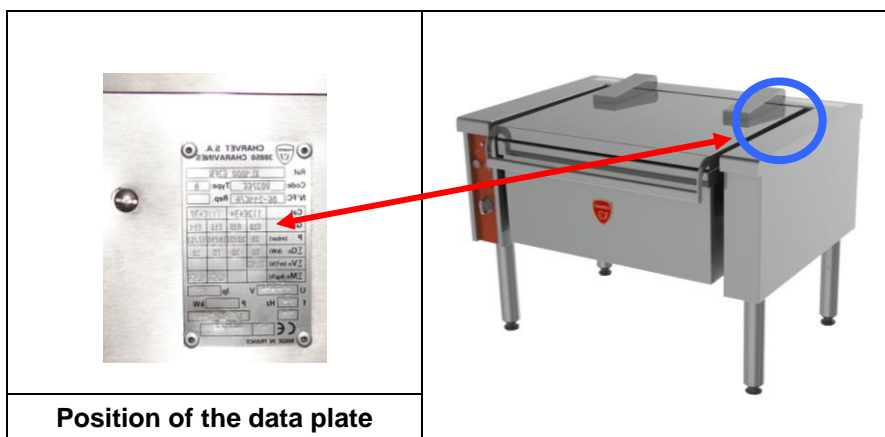

2. POWER CONNECTION

Warning

The appliance must be earth wired.
It is dangerous to connect the appliance unless it is earthed.
We cannot be held responsible for accidents due to non existent or incorrect earth link connection.

Fixed appliance:

Check that the electric network is equipped with all-pole circuit breakers having a cross section of 3.5 mm, and that it complies with the European Standard EN 60335-1 dated of May 2003.

CAUTION:

Use a standardized cable (245 IEC 57 or 245 IEC 66) or other approved cable with the same characteristics.

All controls and checks below are done when the appliance is switched off and cold.

2.1. **Checks before connecting**

- The electrical voltage of the supply is compatible with the voltage of the appliance (see § 4.4.).
- The cable is fixed properly.
- The connections are tight enough.
- The cross-section of the cable is compatible with the voltage of the appliance.

2.2. Connecting the appliance to the mains power supply

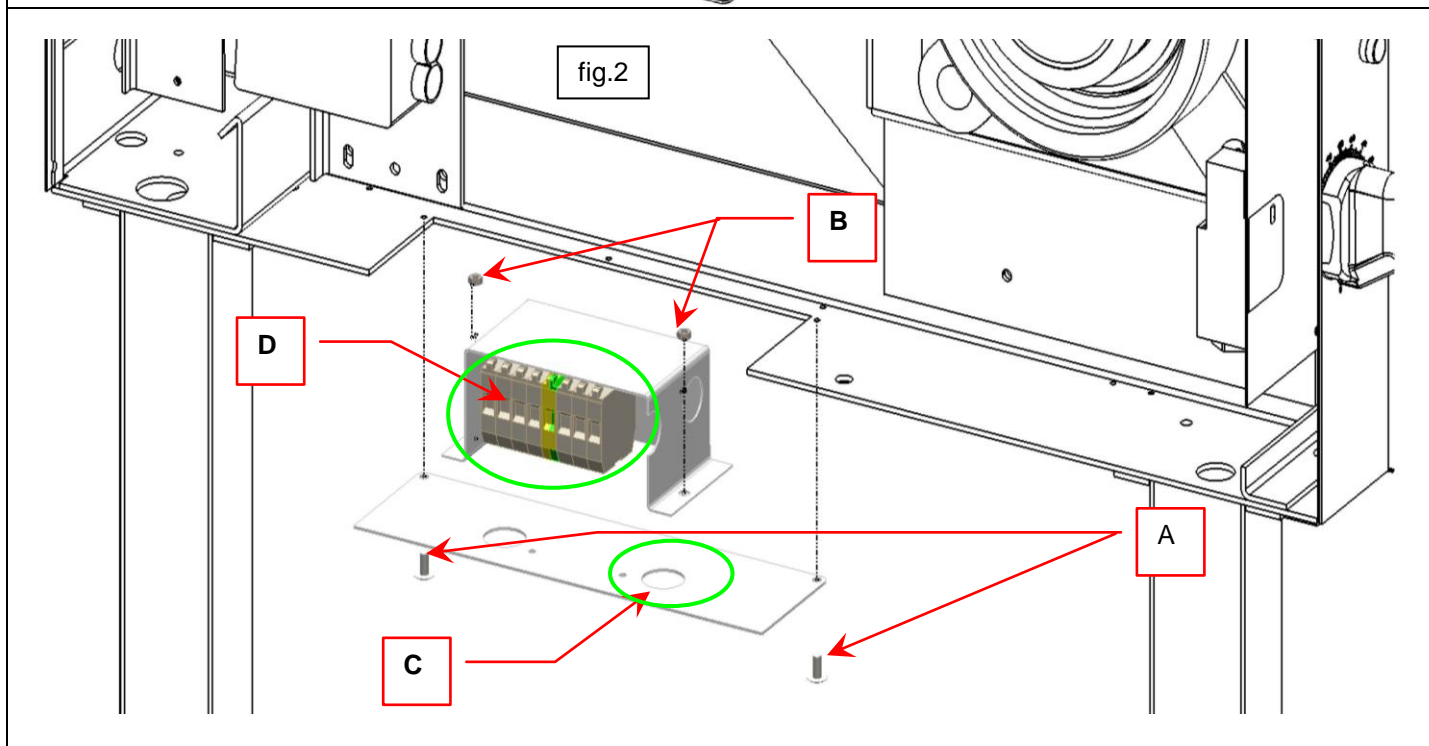
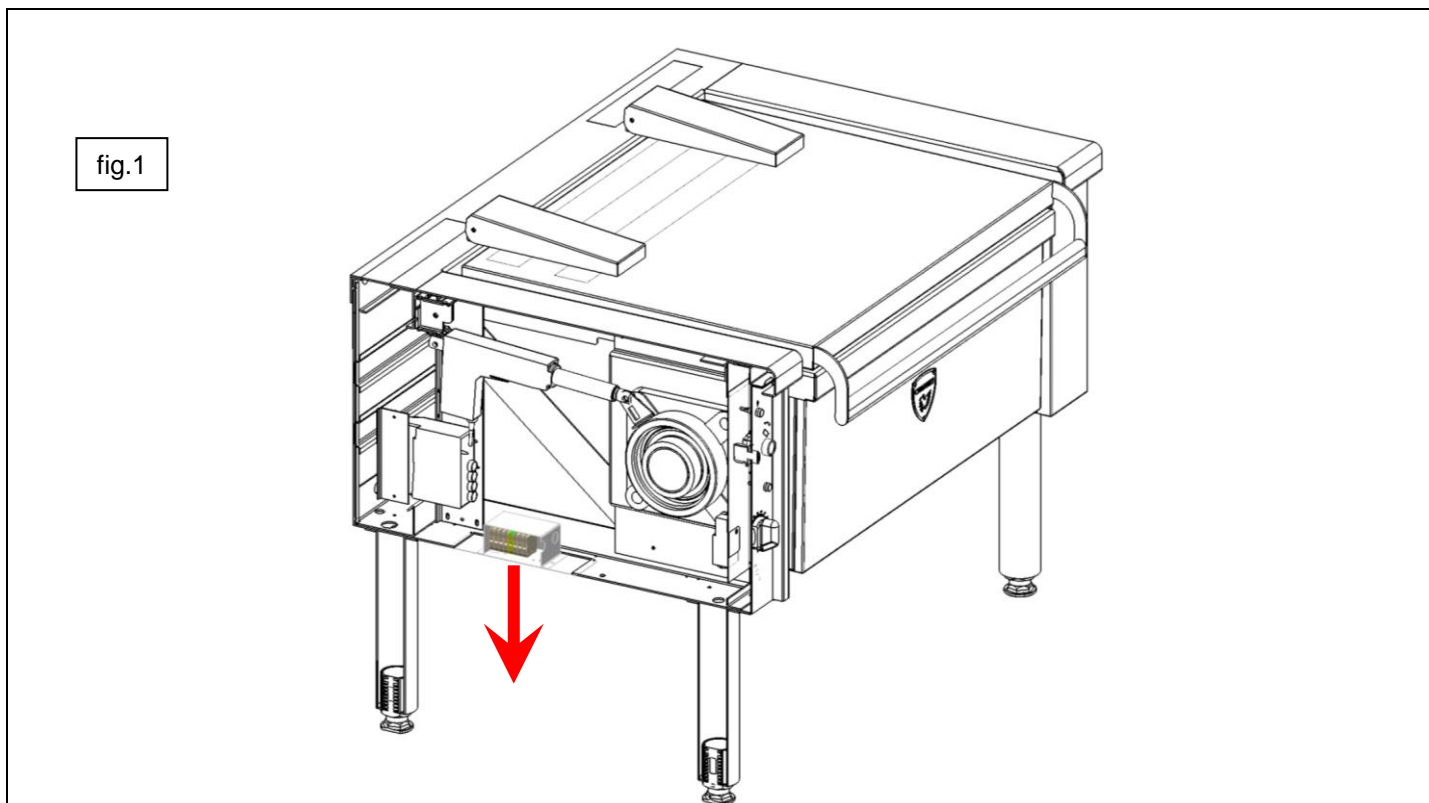

- To access the terminal block:
- Unscrew the support (A), then the switch box fastenings.
- Thread cable through the hole (C).
- Connect the power cable to the terminals, following the information written on the box (see figure below).
- Before reassembling the parts, check the electrical equipment is properly insulated (cable).

2.3. **Checks after connection**

- The appliance is earth wired (see the warnings).
- The equipment is well insulated.
- The appliance is in good working state (ignition, etc.).

Starting up: Please see the User's Manual - "Starting up" section

2.4. **Adapting the appliance to the various grid voltages**

<i>Transformer voltage</i>	⇨				
<i>Power supply configurations</i>	⇩	1~230V + E	3~230V + E	3~400V + E	3~400V+N+E
Tilting bratt pan 50-75		B	A	B	B
Electric diagram			SE0123/02		
Tilting bratt pan 50-75		B	A	B	B
Electric diagram			SE0123/02		
A → Coupling possible B → Please consult Charvet C → Coupling impossible D → No voltage available					

3. **WATER CONNECTION (V02973/V02965)**

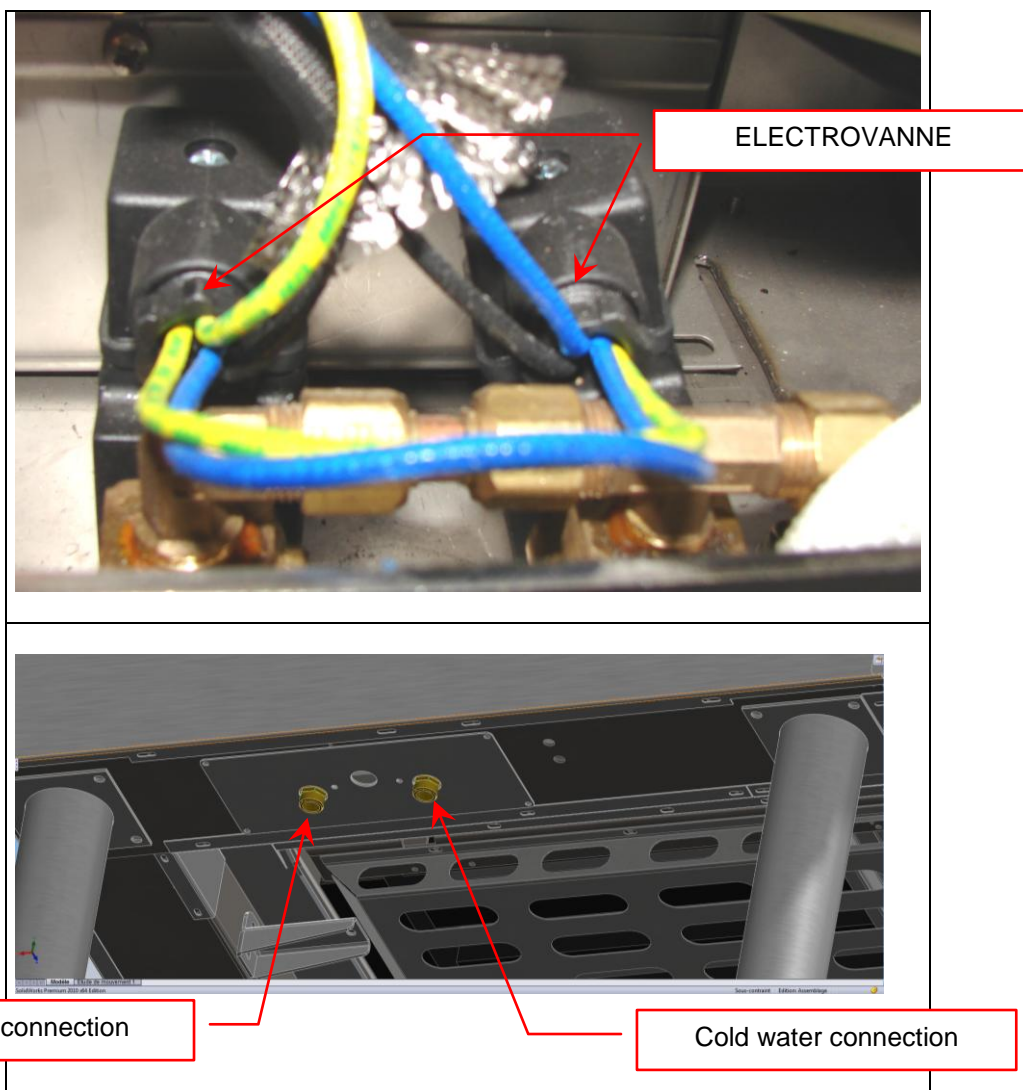

3.1. Removing the solenoid valve

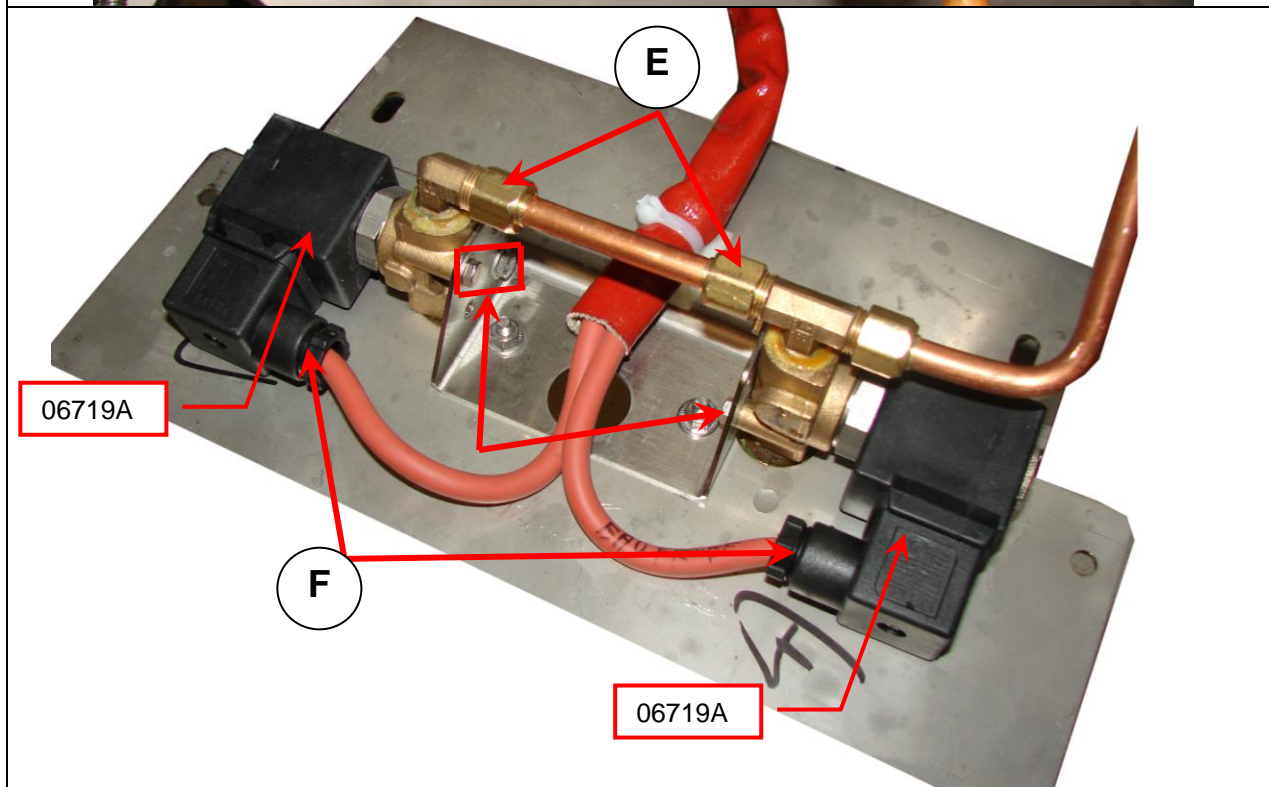
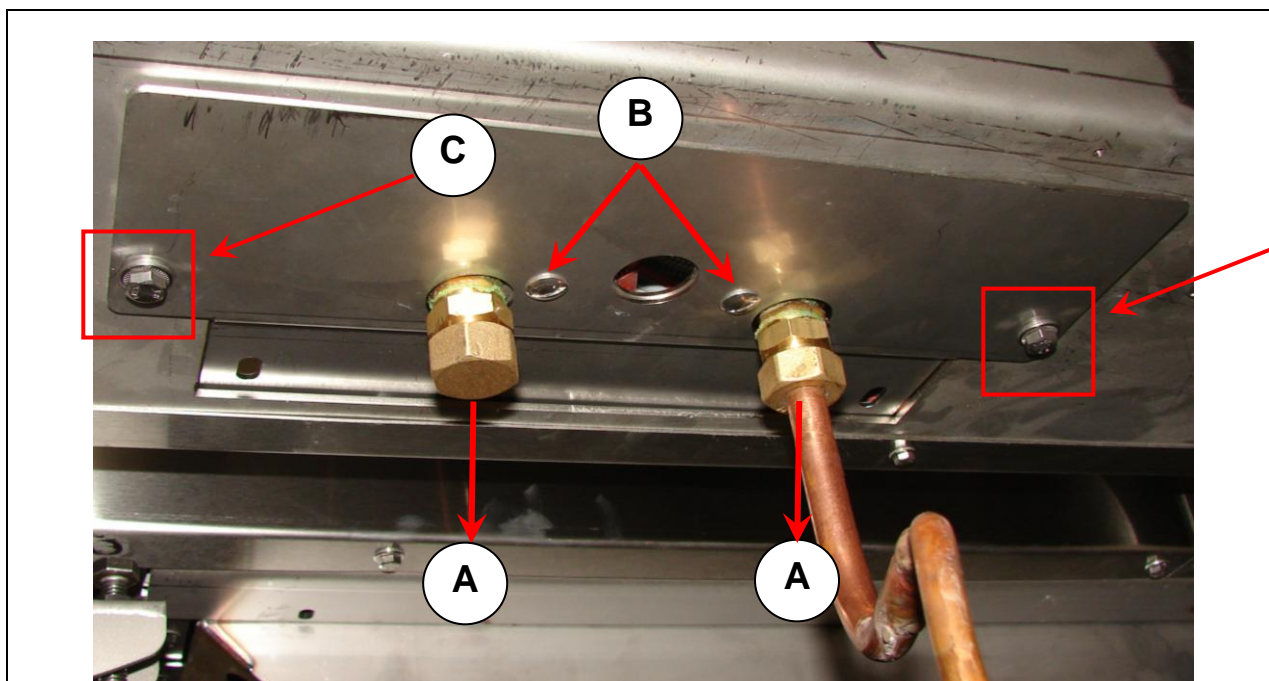

- a) Remove the water supply pipes.
- b) Unscrew the small support (2 screws).
- c) Unscrew the big support (2 screws).
- d) Unscrew the solenoid valve fastenings (4 screws).
- e) Loosen the copper connection.
- f) Disconnect the solenoid valves.

3.2. Checks after connection.

- After connection, ensure that:
- The circuit is watertight.
- Check that the water circuit is in good working order.

4. BASIC SPARE PARTS LIST

Specification	Code	Photograph	Specification	Code	Photograph
Option: Electronic control board for the tilting device.	08793A		Option: Solenoid valve (water)	06719A	
Option: Pulse electronic control board	08794A		Energy regulator 230V	09099A	
Option: Digital display thermostat	504860		Red indicator 230V Green indicator 400V White indicator 400V Amber indicator 230V	505914 505927 505926 505915	
Option: Water meter	08796A		Temperature probe	08783A	
Push button to raise or lower the tank	03967A 07095A		Pulser	09103A	
Electric actuator	08785A		Right lever - limit switch of the tank	506116	
Control box	08786A		Contacteur 400V	00080A	
Strip	02465A		Control knob GAS	505691	

5. MAINTENANCE.

5.1. Changing the heating element (tilting bratt pan 50/75)

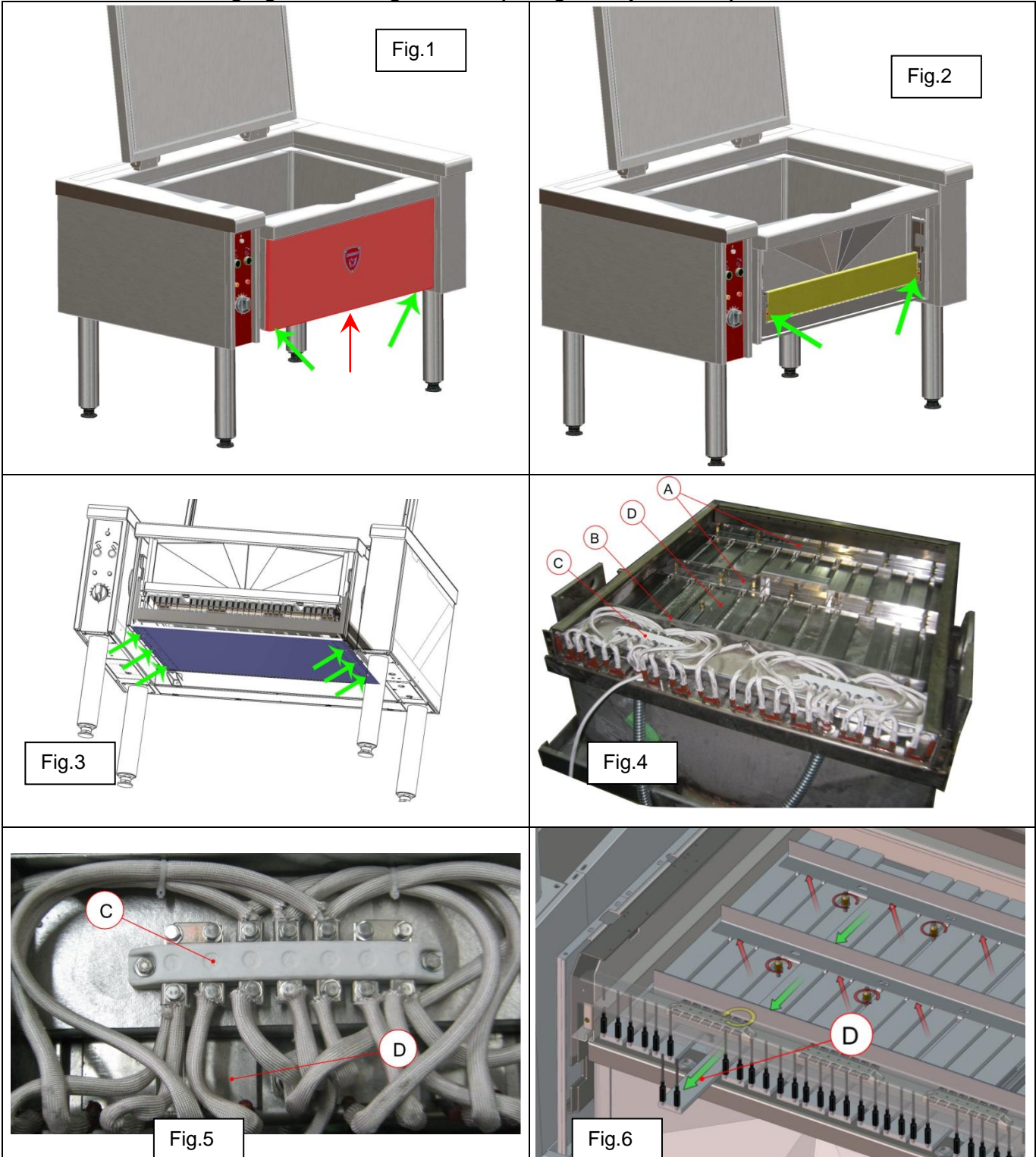

- Remove the cover panel of the tank (Fig. 1) and the lid (Fig. 2).
- Remove the element cover located beneath the tank (Fig. 3)
- (Fig. 4) Loosen the element supports (A) and the baffle (B)
- Disconnect the element from the bar (C) (Fig. 5)
- Slide the element out to remove it (D) (Fig. 6)

6. WIRING

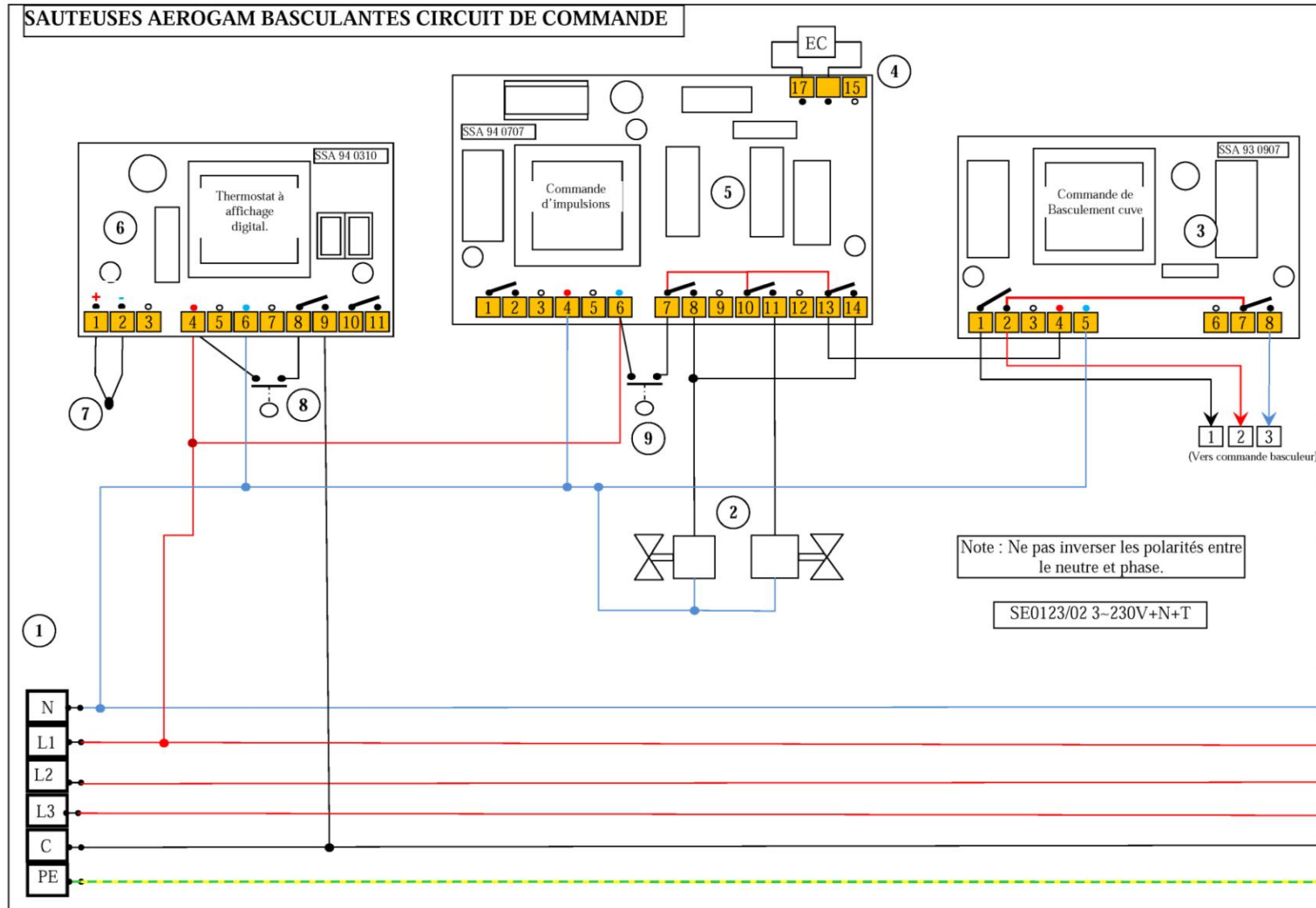

Thermostat with digital display:

- (1 & 2) = Temperature probe
- (4 & 6) = 230V supply
- (8 & 9) = Heating up stage
- (10 & 11) = Accessory relay

Pulse control:

- (1 & 2) = ON/OFF
- (4 & 6) = 230V supply
- (7 & 8) = EV2
- (10 & 11) = EV1
- (13 & 14) = Automatic EV

Control for tilting device:

- (1 & 2) = Control #2
- (4 & 5) = 230V supply
- (7 & 8) = Control #1

Note : Ne pas inverser les polarités entre le neutre et phase.

SE0123/02 3-230V+N+T

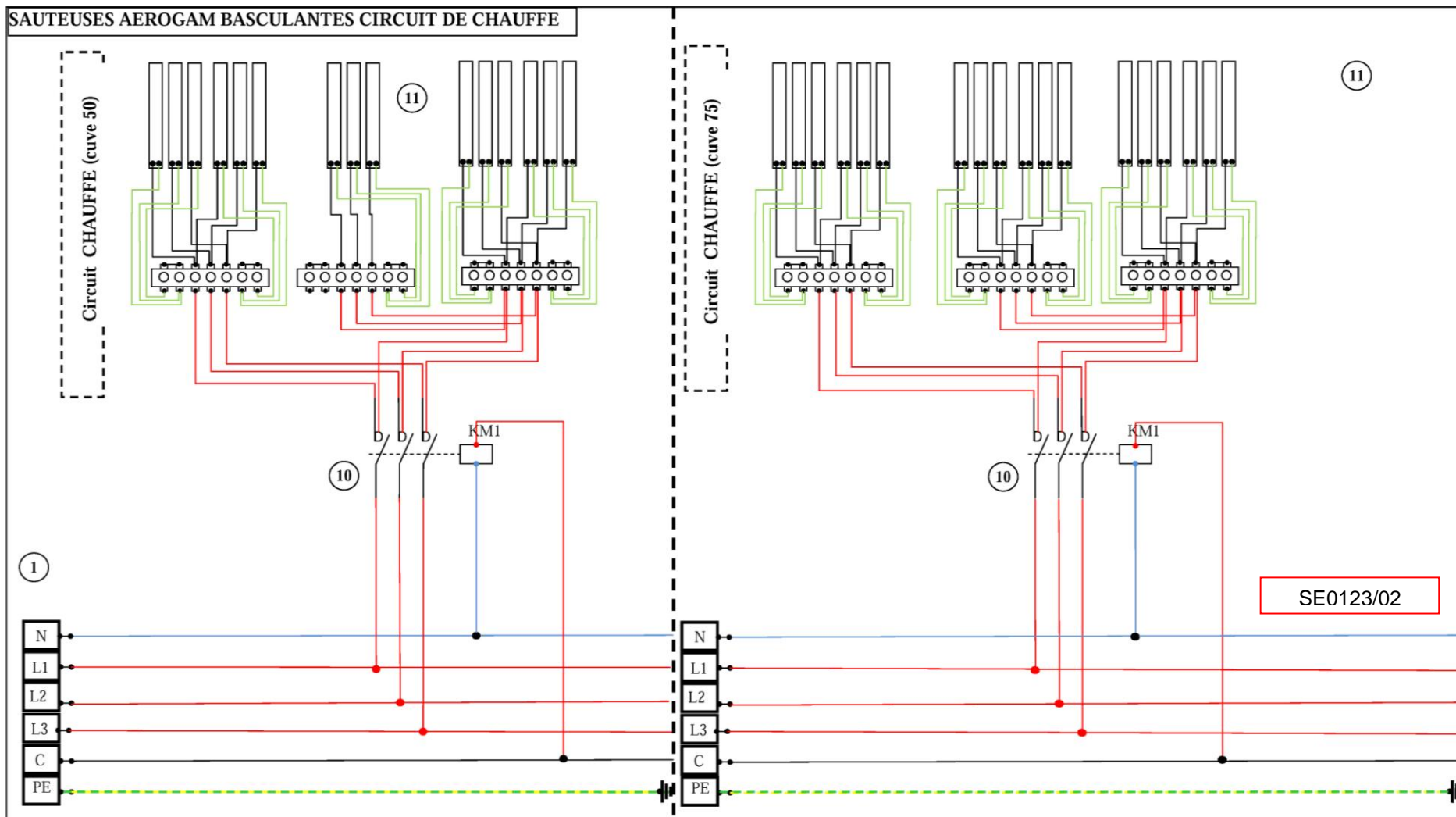

No	Code	Specification	Quantity	No	Code	Specification	Quantity
01	02468A	10mm ² Terminal (brand: Viking)	3	06	08795A	Digital display thermostat	1
01	03575A	10mm ² Earth terminal (brand: Viking)	1	07	08783A	Temperature probe	1
02	06719A	Solenoid valve	2	08	05091A	Limit detector of the tank	1
03	08793A	Control board for tilting device	1	09	05091A	Limit detector of the lid	1
04	08796A	Water meter	1	10	00080A	Contacteur 400V	1
04	09103A	Pulser	1	11	505301	1000W - 230V Flat heating element (50 L tank)	15
05	08794A	Pulse control board	1	11	505301	1000W - 230V Flat heating element (75 L tank)	18

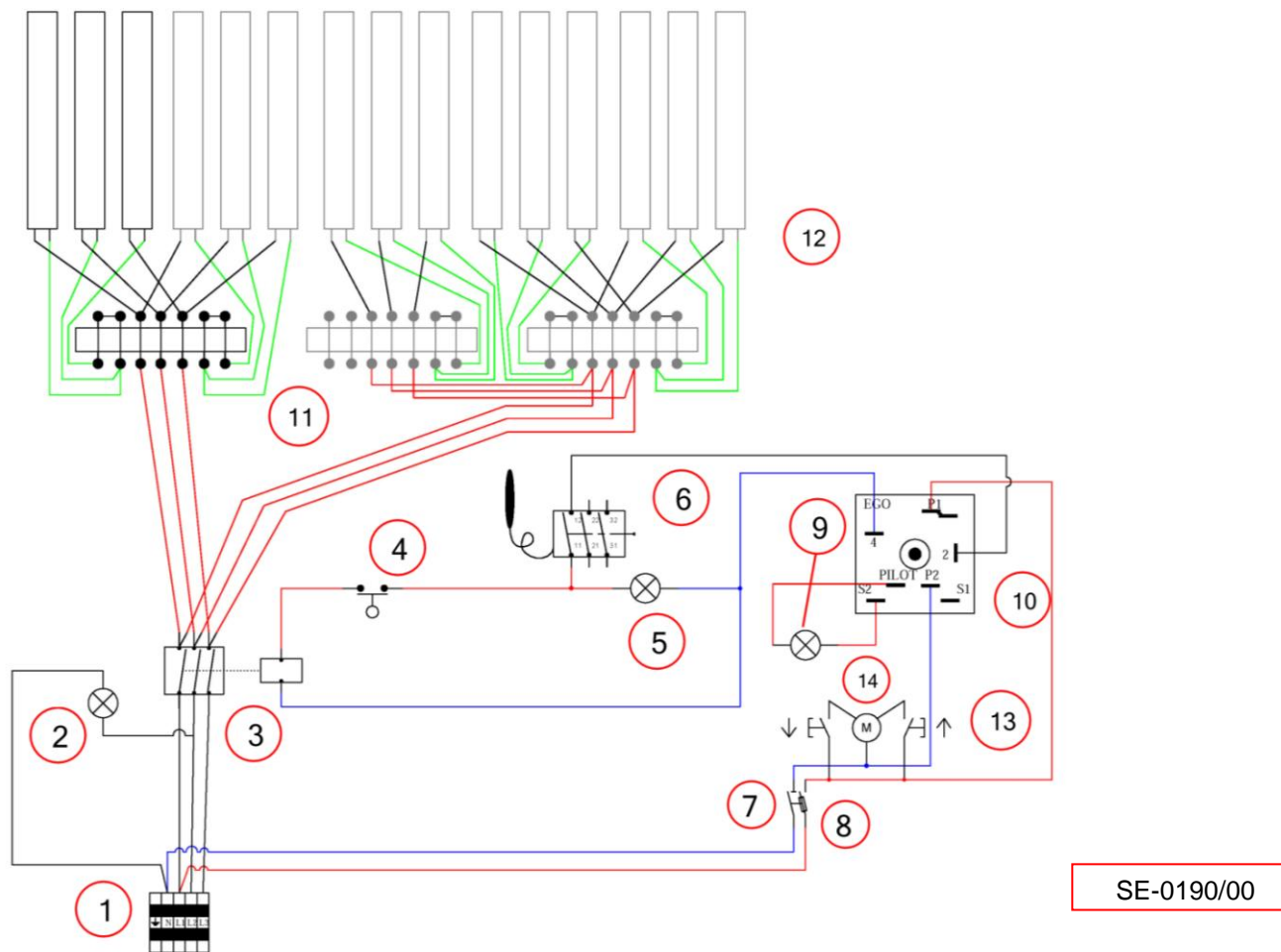

No	Code	Specification	Quantity	No	Code	Specification	Quantity
01	02468A	10mm ² Terminal (brand: Viking)	1	08	02726A	Fuse terminal block disconnecter	1
01	03575A	10 mm ² Earth terminal (brand: Viking)	1	09	505915	230V Amber indicator	2
02	505926	400V White indicator	1	10	09099A	230V Energy regulator	1
03	00551A	230V Contactor	1	11	02465A	7-Pole M4 bar + jumper	3
04	05091A	Limit	1	12	505301	1000W - 230V Heating element	15
05	505914	230V Red heating indicator	1	13	07095A	UP/DOWN push button	2
06	01999A	50°-350°C Tripolar safety thermostat	1	14	08785	LINAK® jack	1
07	500237	Neutral terminal block disconnecter	1				



Electric Tilting Bratt Pan

Specification	PRO 900 SERIES
E1SBE 50 AERO	V02965
E1SBE 50 AERO EL	V02973
E1SBE 75 AERO	V03015
E1SBE 75 AERO EL	V03012



USER'S INSTRUCTIONS

CHARVET

F-38850 – CHARAVINES Pro 900 EN GSB

Tel.: (33)-4-76-06-64-22

Fax: +33 (0) 4 76 55 78 75

Email: info@charvet.fr

Email: sav@charvet-sa.fr



ind. A - Created on: 09-10-2013
Updated on:
Code:

SUMMARY

<u>USER'S INSTRUCTIONS</u>	1
<u>1. PRIOR TO STARTING UP:</u>	3
1.1. CONTROL PANEL	4
<u>2. STARTING UP:</u>	5
2.1. STARTING UP THE WATER SYSTEM:.....	5
2.2. MANUAL WATER FILLING:	5
2.3. PROGRAMMED WATER FILLING:	5
2.4. STARTING-UP THE HEATING PHASE:.....	5
2.5. TILTING DEVICE CONTROL:	5
<u>3. SWITCHING OFF</u>	6
<u>4. MAINTENANCE</u>	6
4.1. CLEANING OF THE STAINLESS STEEL SURFACES:	6
4.2. CLEANING THE TANK.....	6
<u>5 BASIC SPARE PARTS LIST</u>	7

INTRODUCTION

- A) **Our equipment is for professional use only and must be used by qualified staff.**
- B) **The equipment must be installed in compliance with regulations and standards in force in the country of installation, in an adequately aerated room equipped with an air extraction hood.**
- C) **Appliances may be installed side by side or against walls made of non combustible material. Distance to combustible material shall never be less than 10 cm.**
- D) **It is imperative to hire a qualified installer for all new installations or modifications of existing equipment.**
- E) **WARRANTY: *The warranty is discussed in our sale contract. For any warranty claims, please contact an authorized reseller. This warranty does not cover damage due to faulty installation, misuse or inadequate maintenance.***

Warning!

The bratt pan PRO 900 E1SB AERO 50 & 75 is not intended to be used as a fryer.
 Misuse can cause severe damage to the appliance or put people and surrounding equipment in danger.
 We cannot be held responsible if the user(s) neglect to follow these instructions.
 The continued use of the tank when it is empty may damage the appliance.
 The tank must be free of all objects.

1. PRIOR TO STARTING UP:

- a) **Prior to starting up, it is advisable to clean the appliance in order to eliminate all dust and impurities that have accumulated during storage. (see § 2 "Starting Up")**
- b) **Remove all plastic protection wrapping from the stainless steel panels.**
- c) **Make sure that all controls are in good working condition. Turn on the appliance (white indicator).**
- d) **Clean the tank prior to filling it up. Procedure:**
 - **Fill up the tank with soapy water to slightly above the "MAXI" line marked on the tank**
 - **The nominal capacity is 100 litres. (ESBEL50) 150 litres (ESBEL75).**
 - **Bring the water to boiling point; then boil for a few minutes.**
 - **Switch off the appliance, then drain once the appliance has cooled down. When the sides are at a manageable temperature, clean the tank with a smooth sponge in soapy water.**
 - **Rinse thoroughly, and dry the tank.**
- e) **Make sure that the tank is dried prior to filling it up.**

1.1. Control panel

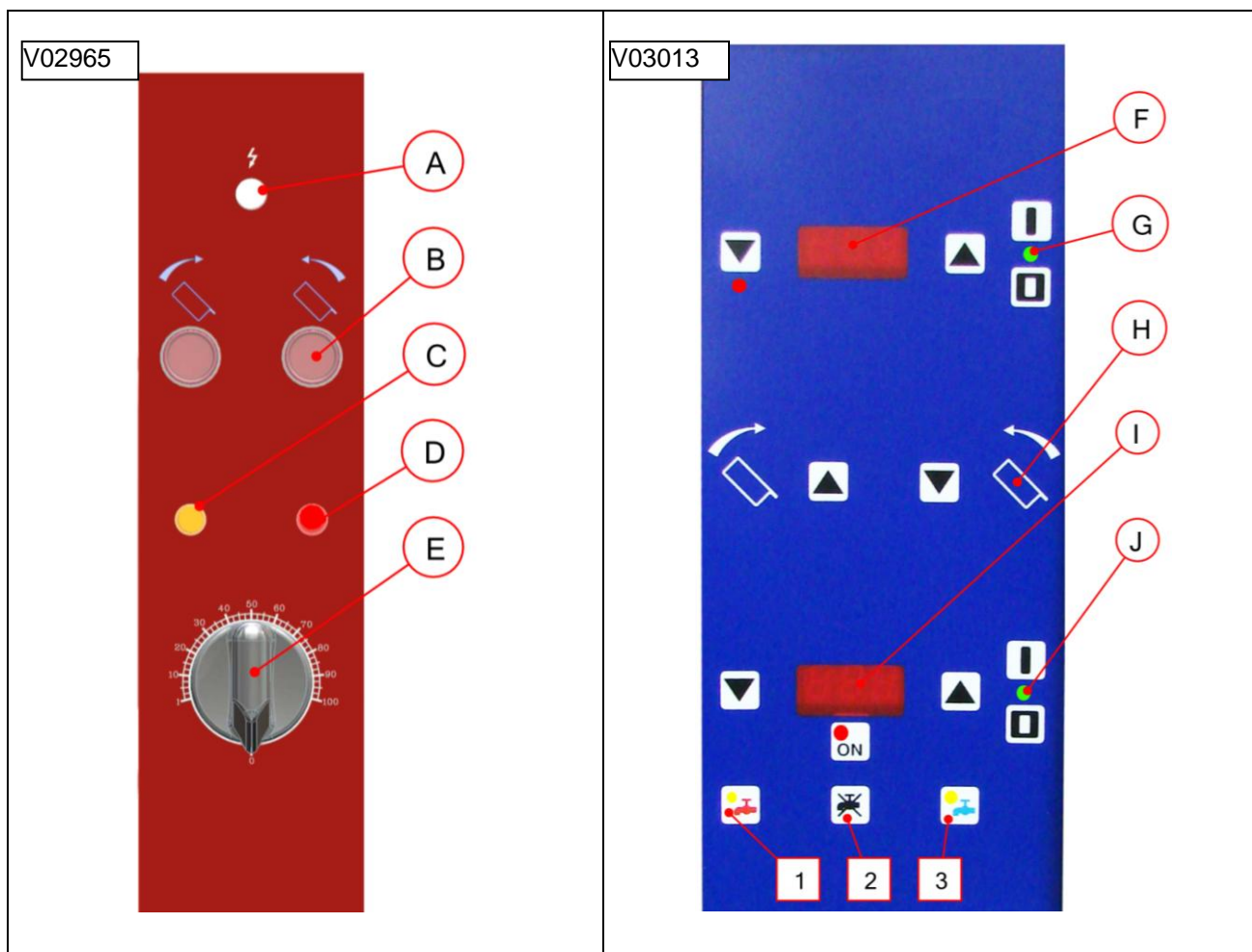

E1SBE V02965 V03015

A	Power on: white indicator.
B	Tilting knob.
C	Amber indicator.
D	Red indicator.
E	Energy regulator.
E1SBEL V02973 V03013	
F	Digital display of the temperature (red heating indicator).
G	ON / OFF (green power-on indicator).
H	Tilting control.
I	Digital display of the amount of water / ON = the programming of the amount of water is switched on.
J	ON / OFF (green power-on indicator of the water control and programming).
1	Hot water.
2	Turn off the water.
3	Cold water.

2. STARTING UP:**E1SBE50 AERO EL****2.1. Starting up the water system:**

Fill the tank with water before use: Please see section "Prior to starting up" to check the nominal capacity.

2.2. Manual water filling:

- a) Push on the "cold water" button (3): the yellow indicator lights up (operation phase). (See the control panel.)
- b) Hold the button until the desired volume of water is reached, and release the button.

2.3. Programmed water filling:

- a) Press the ON button (J). The green indicator lights up (power on).
- b) Choose the amount of water by the means of **+** or **-** (see the control panel).
- c) The selected volume appears on the digital display (I).
- d) Push "ON": the red indicator lights up.
This means that the programming is starting up.

2.4. Starting-up the heating phase:**E1SBE 50/75 AERO EL (electric control)**

Fill the tank with water. Operate the bratt pan.
Press the ON button (G). The green indicator lights up (power on).

E1SBE AERO 50/75 (mechanical control)

Fill the tank with water. Operate the bratt pan.
Turn the control knob (E). The red indicator lights up (power on). The heating elements are on when the amber indicator lights up.

2.5. Tilting device control:

**Note: The bratt pan is equipped with a tilting safety device.
The tilting safety device stops the heating elements when the bratt pan is tilted.**

- a) The appliance is ON.
- b) To tilt the tank down: push the "front tilting" button (H for ref. V03013 and B for ref. V03015). (See the control panel.)
- c) To tilt the tank up: push the "rear tilting" button (H for ref. V03013 and B for ref. V03015).

Warning:

Be careful of escaping steam when opening the lid during "wet" cooking operations, to avoid any risk of burns to the arms when reaching over the tank.

When emptying:

- ***Stay clear of the cooked product pouring zone: risk of splash burns.***
- ***Move with the tank to control pouring in the spout area.***
- ***Tilt the tank backwards to its idle position to avoid spillage of products when changing collection containers.***

The tank sides may be very hot after an intensive and long period of use; only use the electronic control board to tilt the tank.

Warning: This appliance must not be cleaned with mechanical water jets or be subject to a spray of water under pressure. Check that the appliance is disconnected at the main power supply.

3. SWITCHING OFF

Turn the control knob (E) to 0 to turn off the appliance. The red indicator goes OFF, the bratt pan is switched OFF.

When work is over for the day, cut power off at the mains power supply.

4. MAINTENANCE

Before doing anything on the appliance, wait until cooking areas have cooled down.

4.1. Cleaning of the stainless steel surfaces:

a) Switch off the appliance. After each service and before each cleaning operation, we strongly advise you to disconnect the appliance from the mains.

b) Wash with a sponge and soapy water (or any other neutral cleaning product).

Do not use bleach or any other acidic product –even well diluted.

For the tops, use a nylon scouring pad if necessary. Always go with the grain. After each cleaning, rub with an oily rag.

4.2. Cleaning the tank

Cleaning can be done by soaking with water and liquid soap or washing-up liquid.

If coarse salt is poured into the tank for the dry-heat or moist-heat cooking of food, rinse the bottom of the tank thoroughly with clear water to remove all salt particles. Otherwise it will corrode the stainless steel tank.

For best results, have your equipment serviced and cleaned on a regular basis by a qualified installer.

Some parts of this appliance are factory sealed; in case of malfunction, call a registered installer.

Contact the supplier to replace any faulty electric control components before further use.

5 BASIC SPARE PARTS LIST

Specification	Code	Photograph	Specification	Code	Photograph
Option: Electronic control board for the tilting device.	08793A		Option: Solenoid valve (water)	06719A	
Option: Pulse electronic control board	08794A		Energy regulator 230V	09099A	
Option: Digital display thermostat	504860		Red indicator 230V Green indicator 400V White indicator 400V Amber indicator 230V	505914 505927 505926 505915	
Option: Water meter	08796A		Temperature probe	08783A	
Push button to raise or lower the tank	03967A 07095A		Pulser	09103A	
Electric actuator	08785A		Right lever - limit switch of the tank	506116	
Control box	08786A		Contacteur 400V	00080A	
Strip	02465A		Control knob GAS	505691	