



GAS-FIRED BRATT PANS

Description	PRO 800		PRO 900	
G1SBM33I/50I	V02684	V01644		
G1SBE33I/50I	V02512	V01645		
G1SBM33L	V01643			
G1SBM40I/60I			V02686	V01509
G1SBE40I/60I			V01508	V01510



INSTALLATION MANUAL



SUMMARY

1. INSTALLATION.....	3
1.1. GENERAL POINTS.....	3
1.2. HANDLING	3
1.3. INSTALLATION.....	3
1.4. DATA PLATE	4
1.5. FIXING THE LOW FLUE.....	4
2. GAS CONNECTIONS.....	5
2.1. CHECKS BEFORE PROCEEDING	5
2.2. CONNECTING THE APPLIANCE TO THE GAS MAINS.....	6
2.3. CHECKS AFTER CONNECTION.....	6
2.4. CHECKS OF PRESSURE SUPPLY.....	6
3. CONVERSION TO OTHER TYPES OF GAS	6
3.1. CHANGING THE INJECTORS AND ADJUSTING THE AIR	7
3.2. CHANGING THE INJECTORS AND ADJUSTING THE AIR OF THE PILOT LIGHT	8
3.3. GAS ADJUSTMENT CHARTS	9
3.4. ADJUSTING THE SLOW-DOWN POSITION	11
4. POWER CONNECTION	11
4.1. CHECKS BEFORE PROCEEDING	11
4.2. CONNECTING THE APPLIANCE TO THE ELECTRIC NETWORK.....	12
4.3. CHECKS AFTER CONNECTION.....	12
4.4. ADAPTING THE APPLIANCE TO THE VARIOUS ELECTRICAL SUPPLIES VOLTAGE	12
5. WIRING DIAGRAMS	13
6. BASIC SPARE PARTS LIST.....	18
7. MAINTENANCE	20
7.1. ADJUSTING THE BALANCED LID (IN OPTION REF. V00569)	20

1. INSTALLATION

1.1. General points

Installation must be undertaken in compliance with the following instructions and with local codes and bylaws. Ensure you have a suitable and sufficient risk assessment in place.

This appliance is of A-type and shall not be connected to a flue gas pipe.

The user's manual must be given to the user after installation.

1.2. Handling

It is imperative to leave the appliance on its wooden pallet for handling on site until the final installation.

Unpack and check the appliance for damage upon receipt.

In case of damage, mark delivery note accordingly and immediately (within 48 hours) notify the carrier by registered mail with acknowledgement of receipt. Notify your installer.

1.3. Installation

All local fire regulations must be adhered to.

The appliance must be installed under a suitable mechanical extraction hood, close to the electric supply.

If the apparatus is to be installed against a wall or partition, near a piece of furniture or decorative borders, it is recommended that these are made of fireproof material.

If this is not the case, they must be protected by an approved fireproof, insulating material.

If in doubt of fireproof construction of adjacent walls, distance to combustible material shall be no less than 10 cm.

Remove all plastic protection. Install the appliance in the kitchen.

Warning

Fixed appliance:

- Check that the masonry plinth is well horizontally leveled.
Adjust height to level the unit to a horizontal working plan of 900 mm.

• Mobile appliance:

Install the castors (they are delivered in a box kept inside the appliance).
The castors with brakes must be locked when the appliance is being connected and during cooking times. Fix all independent half module against the wall.

**Any technical action on an appliance must be undertaken by a qualified technician.
The appliance will have to be isolated from the electrical supply for the duration of the work.**

When the appliance is ready for use, ensure the users know how to use it properly.
(Please see the user's manual).

WARRANTY: The warranty is mentioned in our conditions of sale.
This warranty does not cover damage due to faulty installation, misuse or inadequate maintenance.

1.4. **Data plate**

Each appliance has its own data plate. Transfer all the information written on the data plate to the part of the user's manual reserved for it.

This will ease the communication between you and your client for better service.

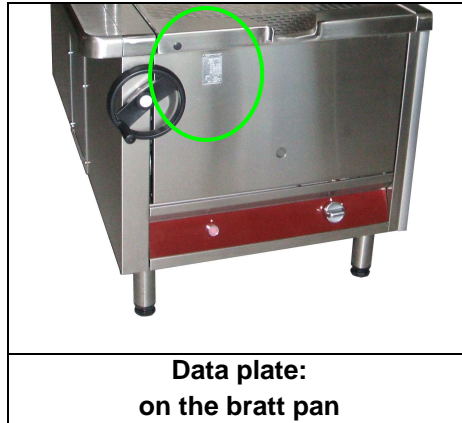

**Data plate:
on the bratt pan**

1.5. **Fixing the low flue**

Install the flue on top of the appliance and ensure the flue is free of obstruction (inside/outside).

<p>You have access to 2 screws located on the right and left sides of the flue (fig.1) and (fig. 2).</p>	<p>Fig.1</p>
<p>Unscrew the screws to lower the fixing tabs (fig.3)</p>	<p>Fig.2</p>
<p>Install the flue above the space reserved for it and slide the fixing fasteners underneath the top of the appliance. Screw the two screws to fix the flue (see fig. 1 and fig. 2).</p>	<p>Fig.3</p>

2. GAS CONNECTIONS

Warnings

- **Fixed appliance:**

Connect the appliance to the gas mains using 1/2" NPT pipe and connections. Install a suitable shutoff valve (or valve + pressure regulator) in the supply line, allowing the unit to be isolated from the rest of the cooking range.

- **Mobile appliance:**

Connect a 1/2 NPT approved armoured flexible gas hose equipped with a quick disconnect fitting including automatic gas shutoff valve to the gas connection located on the rear of the appliance. (Remember to use the security chain).

2.1. Checks before proceeding

Check that:

- The mains should be free of obstructions, and clean.
- Ensure that the gas supply pipe is of the correct size for minimum pressure drop according to length, elbows, and total unit capacity.
- The appliance requires a fresh air input of 2m³/h/kW. (See chart below).
- The type of gas used: Ensure that the appliance is set for the type of gas supplied (nature/pressure); see data plate on the appliance and label on the gas connection.

CHART						
Code		Appliance	Power (kW)		Fresh air input required (m ³ /h/kW)	
V02684	V01644	G1SBM	17.4	26.7	34.8	53.4
V02512	V01645	G1SBM	17.4	26.7	34.8	53.4
V01643		G1SBE	17.4		34.8	
V02686	V01509	G1SBE	22.1	33.2	44.2	66.4
V01508	V01510	G1SBE	22.1	33.2	44.2	66.4

2.2. **Connecting the appliance to the gas mains**

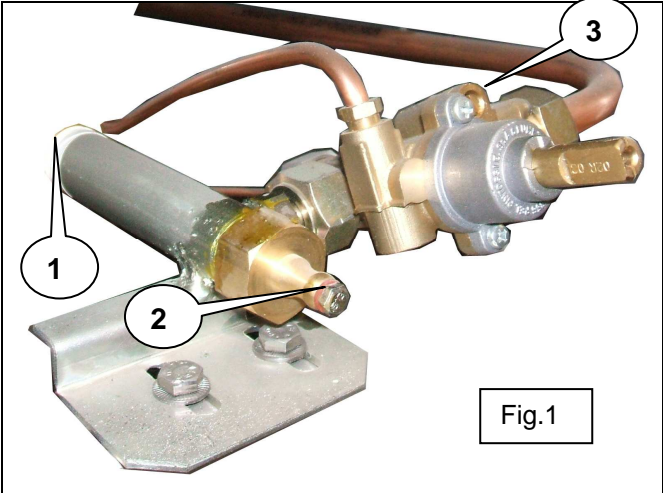
 <p style="text-align: center;">Fig.1</p>	<ol style="list-style-type: none"> 1. Tube M1/2 2. Pressure tap 3. Slow-down screw
<ul style="list-style-type: none"> • Gas bratt pan - Remove the control knobs, - Unscrew the control panel (2 screws), - Connect the appliance to the gas mains using 1/2" M tube (fig. 1), <p>Note: The pressure tap is accessible (see § 2.4.).</p>	

2.3. **Checks after connection**

- The gas circuit is well watertight,
- Supply pressure of the appliance in working state,
- The colour of the flame (blue),
- The slow-down position (see § 3.4.),
- The good working state of the appliance and its safety devices.

2.4. **Checks of pressure supply**

Taking the pressure:

- Remove the control knobs,
- Remove the control panel,
- Connect the manometer on the pressure tap located on the burner ramp,
- Switch ON appliance to maximum setting,
- Then check your figures (see § 3 "Gas Adjustments").

Note: All the appliances connected to the same gas supply should be in working state while taking the pressure supply.

3. CONVERSION TO OTHER TYPES OF GAS

Change of gas upon installation: After having replaced the injectors, ensure of the watertightness of the connection between the injector and its support.

3.1. **Changing the injectors and adjusting the air**

See charts § 3.3. according to the type of burners.

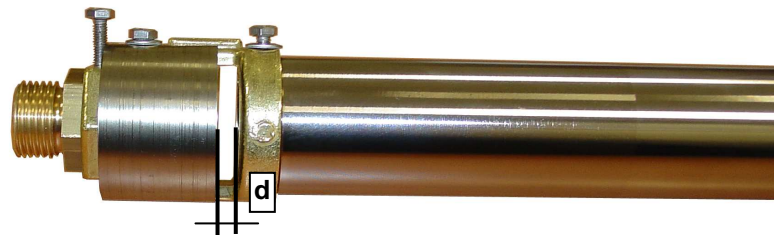

• **Gas bratt pan**

- Remove the control knobs,
- Unscrew the control panel (2 screws),
- You have access to the burner
- Unlock the air ring (nut/ring) and push back the air ring to reach the injector.
- Change the injector(s) with a 12mm ring spanner.
- Adjust distance "d" and lock again with a 7mm open-end spanner.

3.2. Changing the injectors and adjusting the air of the pilot light

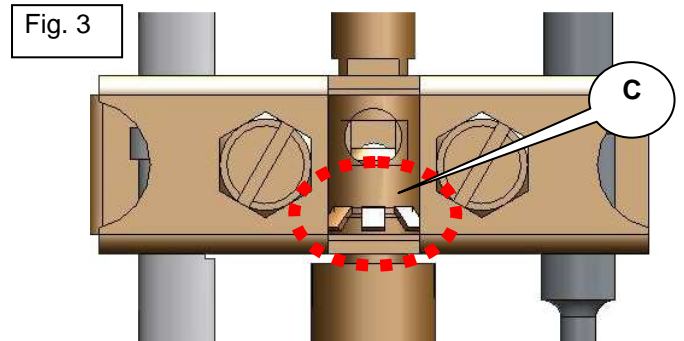
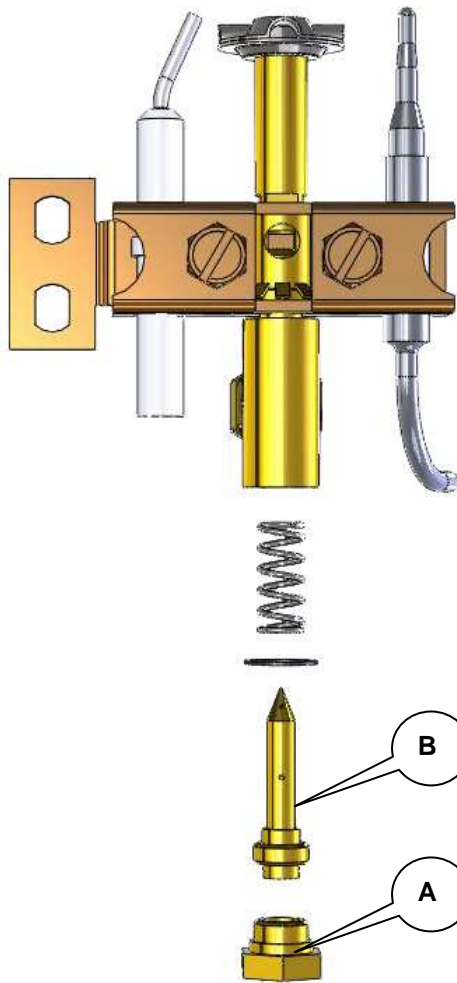

Remove the control knobs,
 Unscrew the control panel (2 screws),
 Unscrew the nut (A) with an open-end spanner 11mm,
 Change the injector (B); see chart § 3.3.
 Adjustment of air ring (Fig. 3 (C)); see chart § 3.3.

Check the watertightness of the gas pipe and the good working condition of the pilot light.

3.3. Gas adjustment charts

Bratt pan 33dm²

Air	Gas type & operating pressure	Mark engraved on the injector	Air adjustment d (mm) ²	Nominal calorific output kW ¹
1	G 20: Pn = 20 mbar	320	3	18
2	G 25: Pn = 25 mbar	320	3	18
3	G 25: Pn = 20 mbar	360	2	17
4	G 30: Pn = 29 mbar	210	5	18
5	G 30: Pn = 50 mbar	180	3	17
6	G 31: Pn = 37 mbar	240	8	23
7	G 31: Pn = 50 mbar	195	3	17

- ¹ Measured power over lower calorific power of the gas (HI) for burner.
- ² Adjustment of measured primary air according to fig. 1

Bratt pan 50dm²

Air	Gas type & operating pressure	Mark engraved on the injector	Air adjustment d (mm) ²	Nominal calorific output kW ¹
1	G 20: Pn = 20 mbar	390	6	26
2	G 25: Pn = 25 mbar	390	6	26
3	G 25: Pn = 20 mbar	n/a	n/a	n/a
4	G 30: Pn = 29 mbar	260	6	26
5	G 30: Pn = 50 mbar	n/a	n/a	n/a
6	G 31: Pn = 37 mbar	260	6	26
7	G 31: Pn = 50 mbar	n/a	n/a	n/a

- ¹ Measured power over lower calorific power of the gas (HI) for burner.
- ² Adjustment of measured primary air according to fig. 1

Bratt pan 40dm²

Air	Gas type & operating pressure	Mark engraved on the injector	Air adjustment d (mm) ²	Nominal calorific output kW ¹
1	G 20: Pn = 20 mbar	350	3	22,1
2	G 25: Pn = 25 mbar			
3	G 25: Pn = 20 mbar	390	3	21.6
4	G 30: Pn = 29 mbar	240	8	23
5	G 30: Pn = 50 mbar	210	6	24
6	G 31: Pn = 37 mbar	240	8	23
7	G 31: Pn = 50 mbar	220	6	23

- ¹ Measured power over lower calorific power of the gas (HI) for burner.
- ² Adjustment of measured primary air according to fig. 1

Bratt pan 60dm²

Air	Gas type & operating pressure	Mark engraved on the injector	Air adjustment d (mm) ²	Nominal calorific output kW ¹
1	G 20: Pn = 20 mbar	300	10	33
2	G 25: Pn = 25 mbar			
3	G 25: Pn = 20 mbar	330	3	30
4	G 30: Pn = 29 mbar	190	Max	28
5	G 30: Pn = 50 mbar	175	Max	29
6	G 31: Pn = 37 mbar	190	Max	28
7	G 31: Pn = 50 mbar	185	Max	28

- ¹ Measured power over lower calorific power of the gas (HI) for burner.
- ² Adjustment of measured primary air according to fig. 1

Pilot light

Air	Gas type & operating pressure	Mark engraved on the injector	Air adjustment d (mm)
1	G20: Pn = 20 mbar	40	4
2	G 25: Pn = 20 mbar		
3	G 25: Pn = 25 mbar		
4	G 30: Pn = 29 mbar	20	5
5	G 30: Pn = 50 mbar		
6	G 31: Pn = 37 mbar		
7	G 31: Pn = 50 mbar		

3.4. **Adjusting the slow-down position**

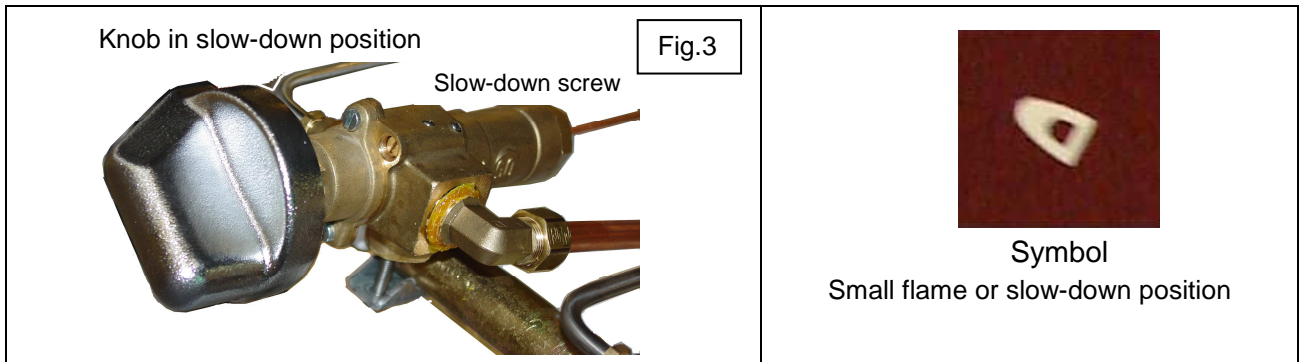

- Adjusting the slow-down position of the burner

Remove the control knobs,
 Remove the control panel (see § 2.2. – gas connections)
 Refit in place the control knob
 Switch ON the appliance. (See the user's manual, § 3).
 Set control knob to the slow-down position (fig. 3)
 Adjust the screw.
 To increase the slow-down position, unscrew the screw (fig. 3)

Note: The burner must remain alight when changing from maximum output to minimum output.

4. POWER CONNECTION



Warnings:

The appliance must be earth wired.
It is dangerous to connect the appliance unless it is earthed.
We cannot be held responsible for accidents due to non existent or incorrect earth link connection.

Fixed appliance:

Check that the electric network is equipped with all-pole circuit breakers having a cross section of 3.5 mm at least. All electrical equipment must be in compliance with the standard EN 60335-1.

WARNING:

Use a standardized cable (245 IEC 57 or 245 IEC 66) or other approved cable with the same characteristics.

All controls and checks below are done when the appliance is switched off and cold.

4.1. **Checks before proceeding**

Check that:

- The electrical voltage of the supply is compatible with the voltage of the apparatus (see data plate and § 4.4).
- The cable is fixed properly,
- The connections are tight enough,
- The section of the cable is of correct size according to the voltage of the apparatus.

4.2. **Connecting the appliance to the electric network**

Electric ignition

Unscrew the front control panel to access the connection box, (see § “Gas connection” Fig. A).

Thread cable through the terminal box (fixed with 2 screws).

Connect cable to the terminals, and follow the information written on the terminal box.

Before reassembling the parts, check the electrical equipment is properly insulated (cable).

Note: The ignition push buttons and indicators should remain in place.

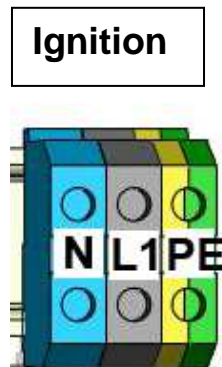

4.3. **Checks after connection**

- The appliance is earth wired,
- The electric equipment is well isolated from the rest of the equipment,
- The appliance is in good working state (ignition, etc.),

STARTING UP: Please see the user’s manual, section “Starting up”

4.4. **Adapting the appliance to the various electrical supplies voltage**

<i>Voltage</i>	⇨			
<i>Various voltages</i>	⇩	1~230V + E	3~230V + E	3~400V + E
	Wiring diagrams #	S = standard coupling		
Electric ignition	SE0001/00	S	A	A
Three-phase electric tilting	SE0019/00	B	B	S
Bratt pan + ignition + regulation	SE0028/00	S	A	A
Pan tilt safety cut out	SE0035/00	S	A	A
Safety reset device	SE0159/00	S	A	A
A → Coupling possible B → Please consult Charvet C → Coupling impossible D → No voltage available				

5. WIRING DIAGRAMS

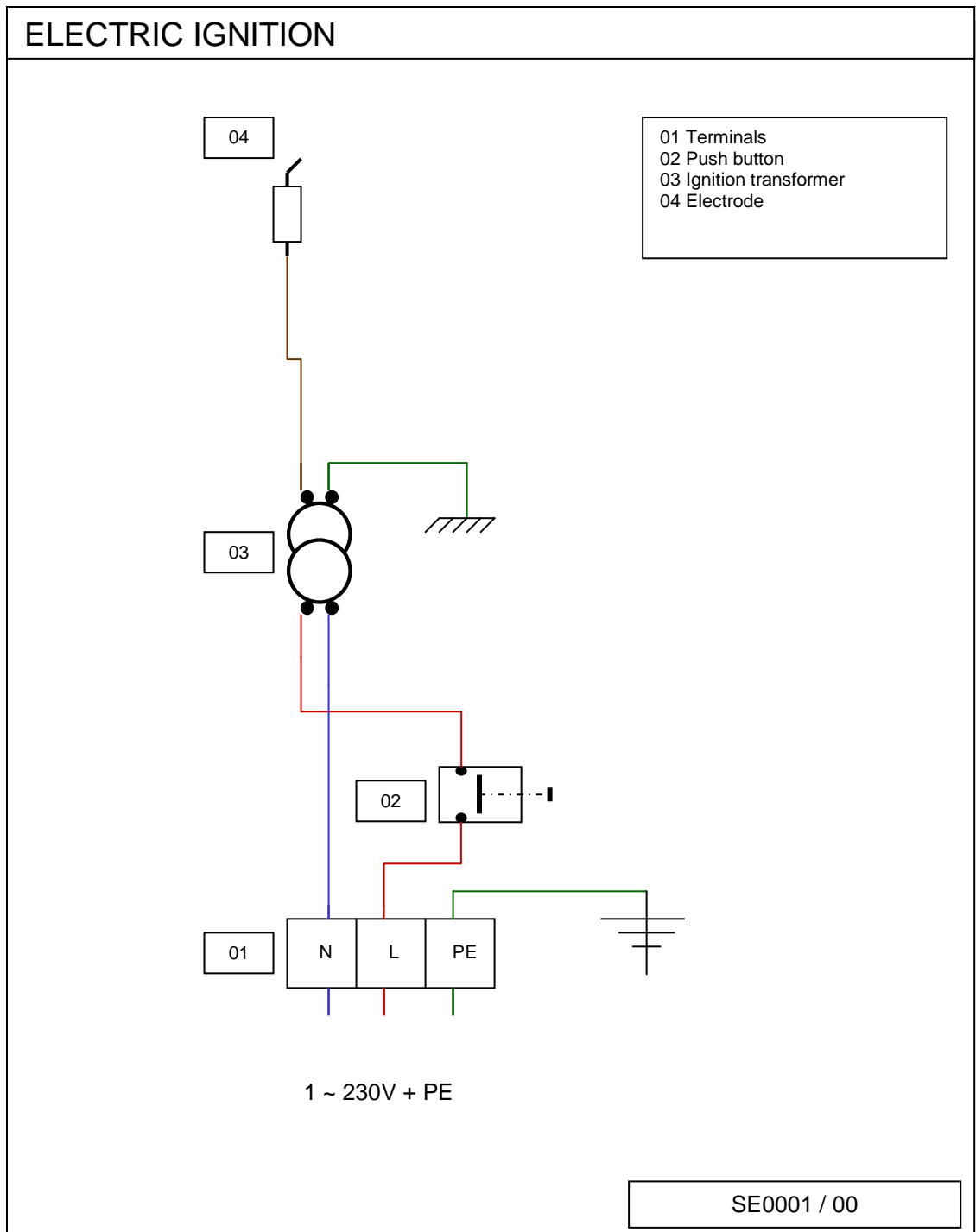

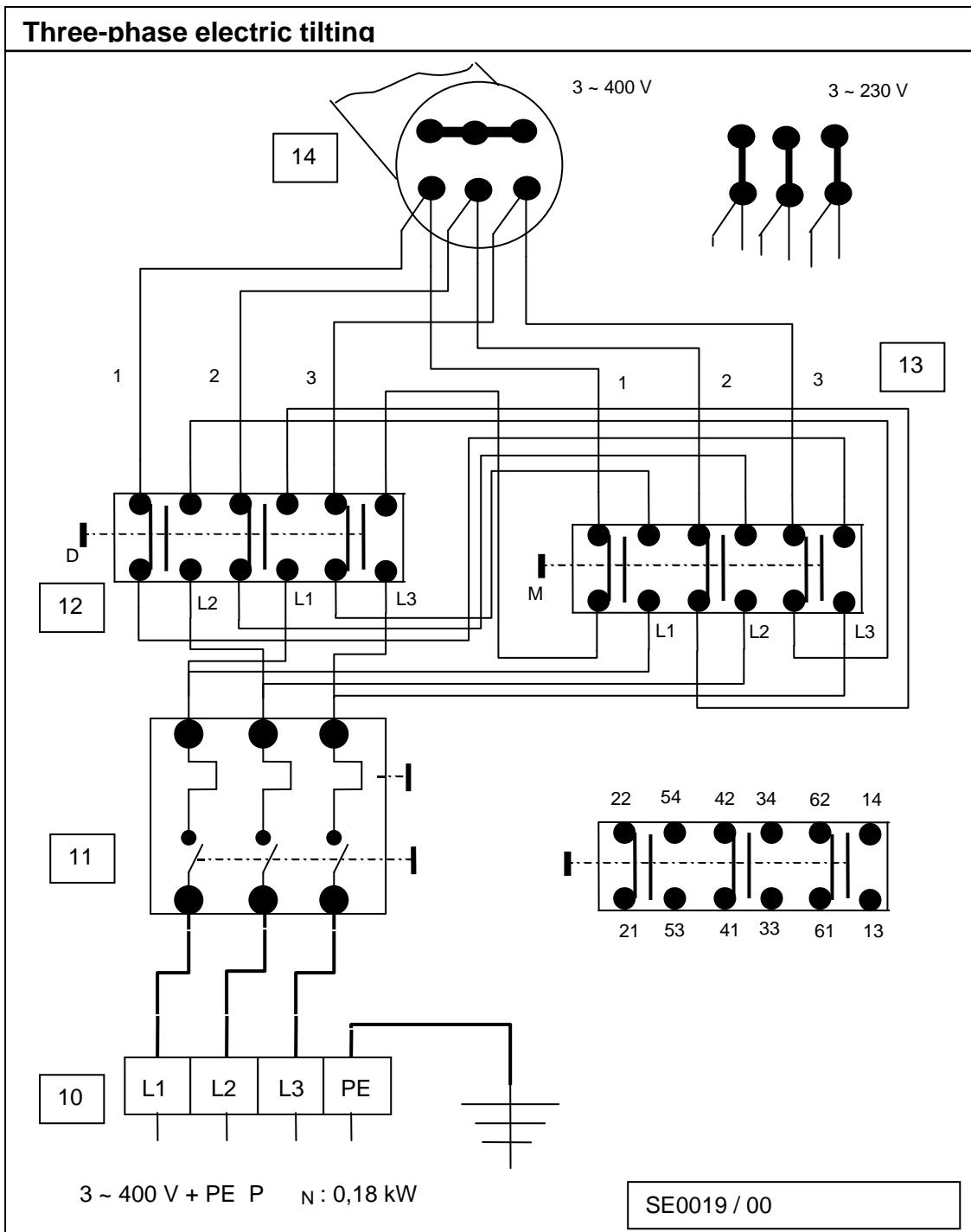

NOMENCLATURE: Three-phase electric tilting mechanism (wiring diagrams: SE0019 / 00)

Mark	Code	Description	Quantity
10	02468A	10 mm ² terminal (brand: Viking)	3
10	03575A	10 mm ² Earth terminal (brand: Viking)	1
11	03775A	Circuit breaker	1
12	02522A	Push button (DOWN)	1
13	02521A	Push button (UP)	1
14	03475A	Electric jack	1

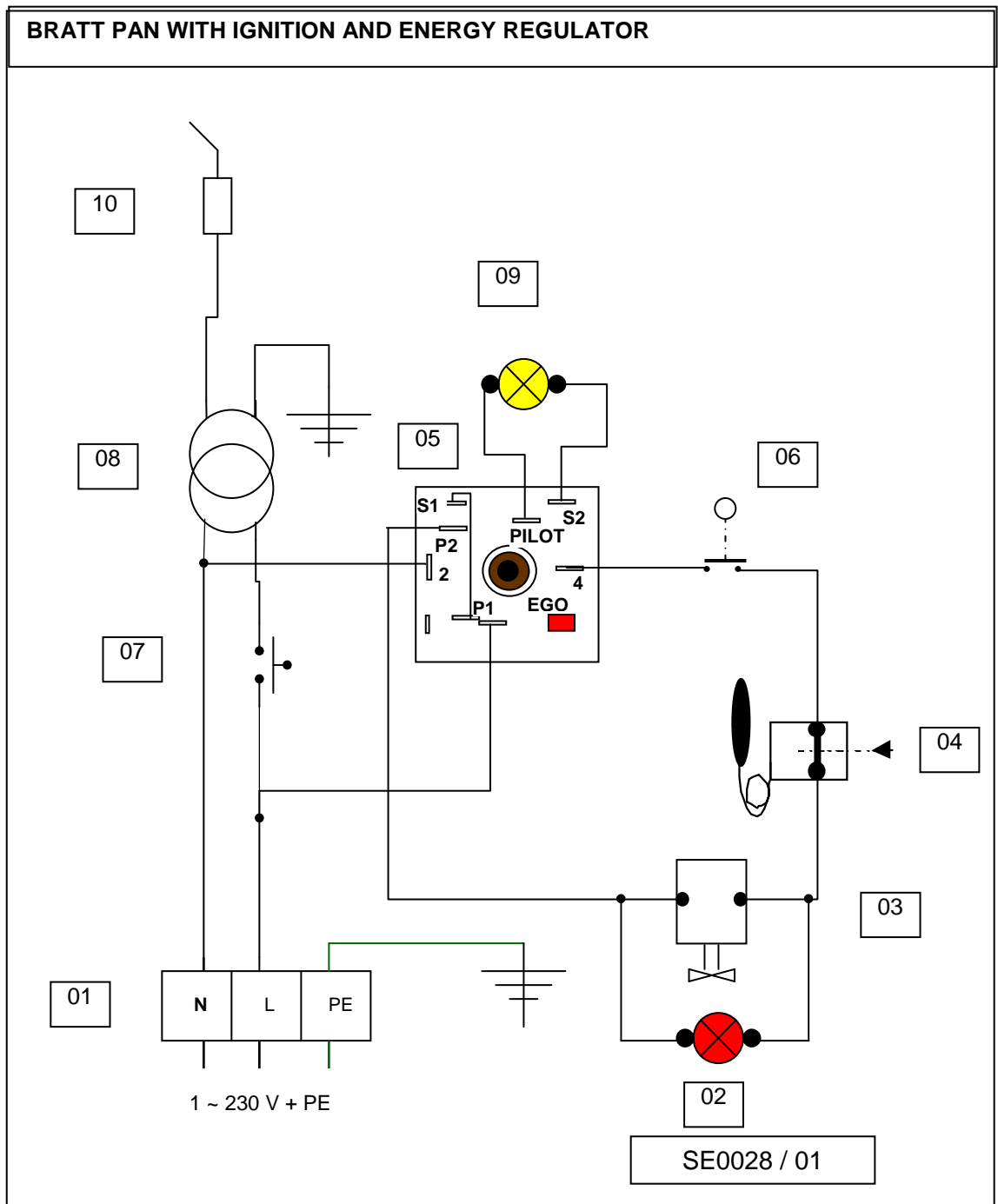

Nomenclature: Bratt pan with ignition and regulation (in option)

Mark	Code	Description	Quantity
01	02468A	10 mm ² terminal (brand: Viking)	1
01	07069A	Blue terminal Vicking	1
01	03575A	10 mm ² Earth terminal (brand: Viking)	1
02	07137A	Red indicator 230 V	1
03	05405A	Solenoid valve	1
04	01999A	Thermostat 50°C-350°C	1
05	09099A	230V Energy regulator	1
06	05092A	Limit detector	1
07	03967A	Push button	1
08	05917A	Ignition transformer	1
09	07140A	Yellow indicator 230V	1
10	05315A	Spark plug	1

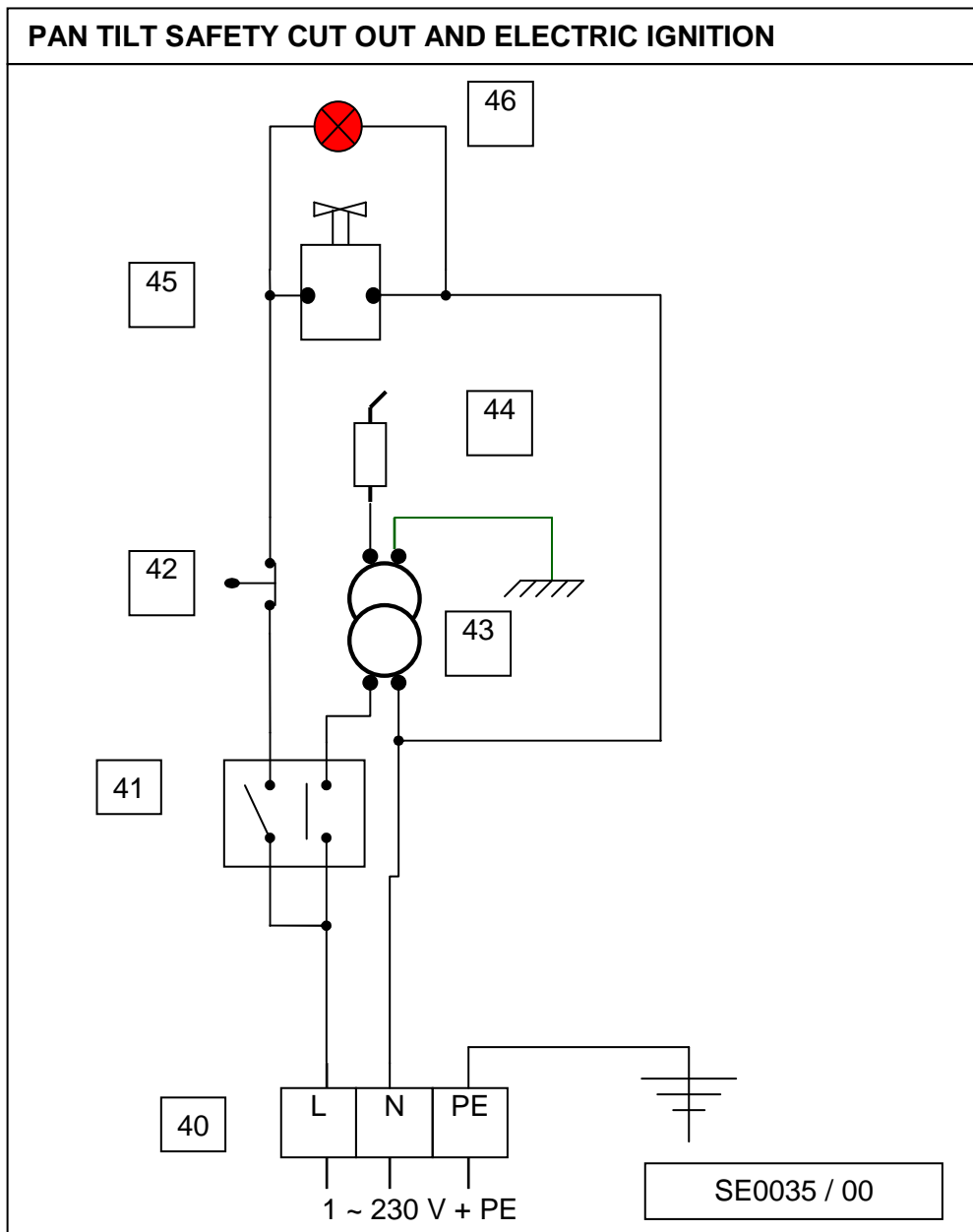

NOMENCLATURE: Pan tilt safety cut out and electric ignition (in option)

Mark	Code	Description	Quantity
40	02466A	4 mm ² terminal (brand: Viking)	1
40	02467A	6 mm ² terminal (brand: Viking)	1
40	03575A	6 mm ² Earth terminal (brand: Viking)	1
41	00077A	Switch MAF LC22-8901	1
42	05091A	Limit detector	1
43	02161A	Ignition transformer	1
44	07010A	Spark plug	1
45	00515A	Solenoid valve	1
46	07137A	Red indicator 230V	1

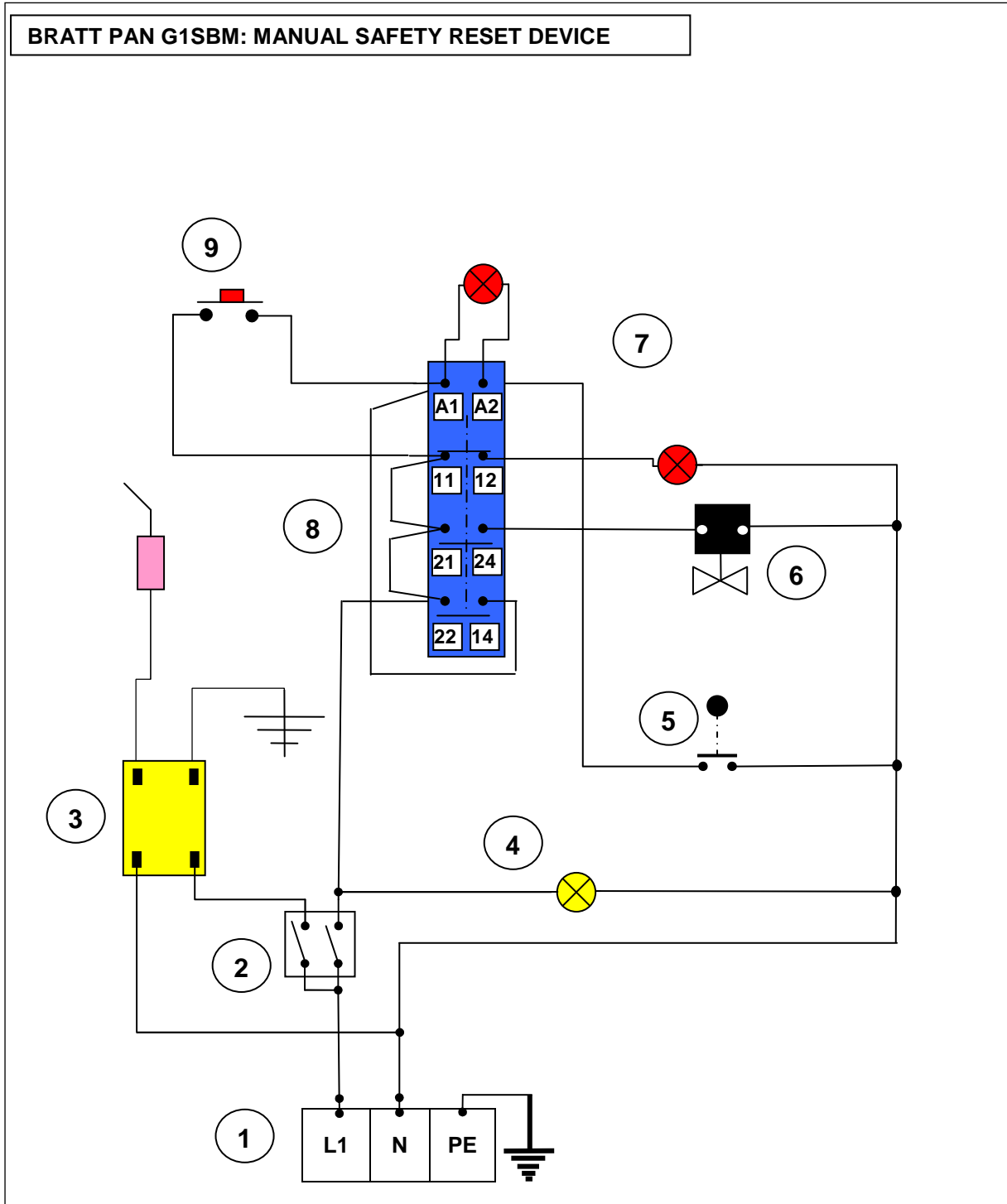







Nomenclature: Bratt pan G1SBM: manual safety reset device (in option) (SE0159/00)

Marks	Code	Description	Quantity
01	02468A	10 mm ² terminal (brand: Viking)	2
01	03575A	Earth terminal (brand : Viking)	1
02	02104A	Switch	1
03	02161A	Electric ignitor 240V	1
04	07139A	Yellow indicator: switched on	1
05	05092A	Limit detector	1
06	05450A	Solenoid valve	1
07	07136A	Red indicator	1
08	08164A	Support for terminal	1
08	08243A	Relay 220V	1
09	03967A	Push button	1

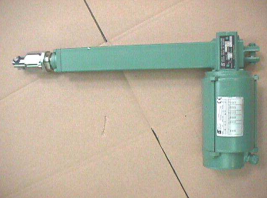
6. BASIC SPARE PARTS LIST

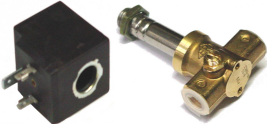

Description / Code	Photograph	Description / Code	Photograph
Gas tap 00312A		Thermocouple coil (gas tap) 00394A	
Injector 00205A Ø 2.10 Propane 00215A Ø 3.10 Natural		Thermocouple Burner 00290A	
3-flame pilot light Natural 07551A Propane 07550A		Electrode 05315A	
Pilot light injector Propane 01157A Natural 06430A		Thermostat 350°C 01999A	
Gear box 33 & 40 dm ² 100926 Cog 08588A		Transformer 05917A	
Gear box 50 & 60 dm ² F15855		Red indicator 230V - 07137A Yellow indicator 230V - 07140A	

Gas-fired bratt pans

Description / Code	Photograph	Description / Code	Photograph
Wheel 04183A		Energy regulator 230 V 09099A	
Electric jack 03475A		Electric ignitor 240V 02161A	
Gas spring 07780A		High voltage cable 03013A	
Solenoid valve 05405A		Push button for ignition 03967A	
Limit detector 05092A		Push button Up / Down / Ignition 02521A 02522A	

7. MAINTENANCE

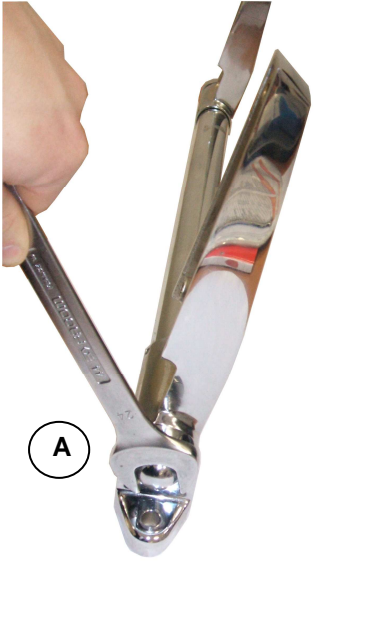
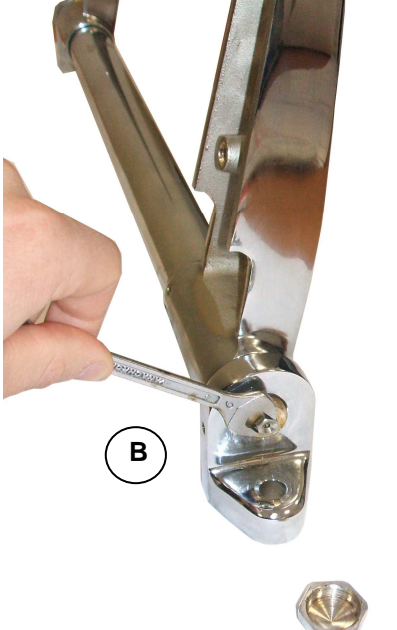
7.1. Adjusting the balanced lid (in option ref. V00569)

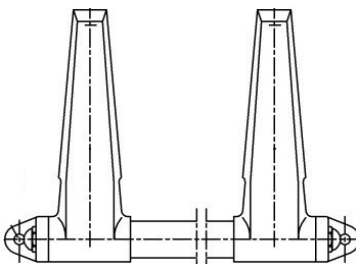
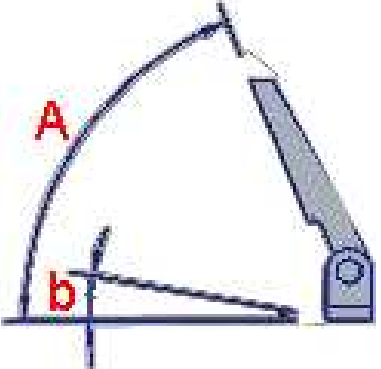
 <p>A</p>	 <p>B</p>	 <p>C</p>
	 <p>A</p> <p>b</p>	<p>Possible opening angles (A)</p> <ol style="list-style-type: none"> 1. 65° 2. 70° 3. 75° 4. 80° 5. 85° 6. 90° <p>Minimum opening angle (B)</p> <ol style="list-style-type: none"> 1. 10°
<ul style="list-style-type: none"> • Remove the plug (a) with an open-end spanner 24mm • Then remove the nut (b) with an open-end spanner 9mm • Adjust with a hex key (c) (refer to the opening angles figures above). 		



GAS-FIRED BRATT PANS

Description	PRO 800		PRO 900	
G1SBM33I/50I	V02684	V01644		
G1SBE33I/50I	V02512	V01645		
G1SBM33L	V01643			
G1SBM40I/60I			V02686	V01509
G1SBE40I/60I			V01508	V01510



USER'S INSTRUCTIONS



SUMMARY

1. INTRODUCTION	3
2. PRIOR TO STARTING UP	3
3. STARTING UP	4
3.1. GAS BRATT PAN.....	4
3.2. TILTING PROCEDURE	5
3.3. FITTING THE REMOVABLE S/S DRAINING BOARD (IN OPTION REF. V02489)	5
4. SWITCHING OFF	6
5. MAINTENANCE	6
5.1. CLEANING OF THE STAINLESS STEEL SURFACES:	6
5.2. CLEANING THE TANK	6
5.3. CLEANING THE BURNER.....	6
6. BREAKDOWN.....	7
6.1. UNSATISFACTORY HEATING	7
6.2. FAULTY IGNITION.....	7

1. INTRODUCTION

- A) Our equipment is for professional use only and must be used by qualified staff.
- B) The equipment must be installed in compliance with local codes and bylaws. It must be installed in a kitchen equipped with an adequately sized mechanical extraction system.
- C) Appliances may be installed side by side or against walls of non combustible material. Distance to combustible material shall be no less than 10 cm.
- D) It is imperative to call for a qualified engineer for all new installations or modifications of existing equipment.
- E) *WARRANTY: The warranty is mentioned in our conditions of sale. Only a qualified engineer certifies the validity of the warranty. This warranty does not cover damage due to faulty installation, misuse or inadequate maintenance.*

2. PRIOR TO STARTING UP

- a) Remove all plastic protection that wraps the stainless steel panels.
- b) Make sure that all controls are in good working condition before turning the gas on.
- c) Prior to starting up, it is advisable to clean the appliance in order to eliminate all dust and impurities that have accumulated during storage.
- d) Pour the tank with water (1-2 cm high),
- e) Preheat for 10 mn about.
- f) Then turn off the appliance.
- g) Tilt the tank to drain (see § 3.2.).
- h) Clean the tank with a sponge to eliminate all remaining impurities.

3. STARTING UP

Overview: Each burner is equipped with a safety thermocouple and a pilot light.

3.1. Gas bratt pan

Push and turn counter-clockwise the control knob of the burner to the spark symbol,
 Keep pushing thoroughly while presenting a flame or pressing the ignition push button (if fitted),
 Keep the control knob pressed for 5 to 15 sec. before releasing it,
 The pilot light must remain ignited, Repeat the operation if it fails,
 When the pilot light is on, turn the control knob counter-clockwise to the desired position (large flame symbol); the burner is running at full power,
 By turning the control knob to the next position (small flame symbol), the burner is on the slow-down position (simmering position),



Basic bratt pan with ignition



Bratt pan with ignition and pan tilt safety cut out



Bratt pan with ignition and energy regulator



Bratt pan with ignition and manual safety reset

- | | |
|--|--|
| <ul style="list-style-type: none"> 1. Gas knob 2. Electric ignition push button 3. Red indicator: Heating
Yellow indicator ON | <ul style="list-style-type: none"> 4. Pan tilt safety cut out switch 5. Energy regulator 6. ON / OFF switch 7. Safety red indicator 8. Reset knob |
|--|--|

3.2. Tilting procedure

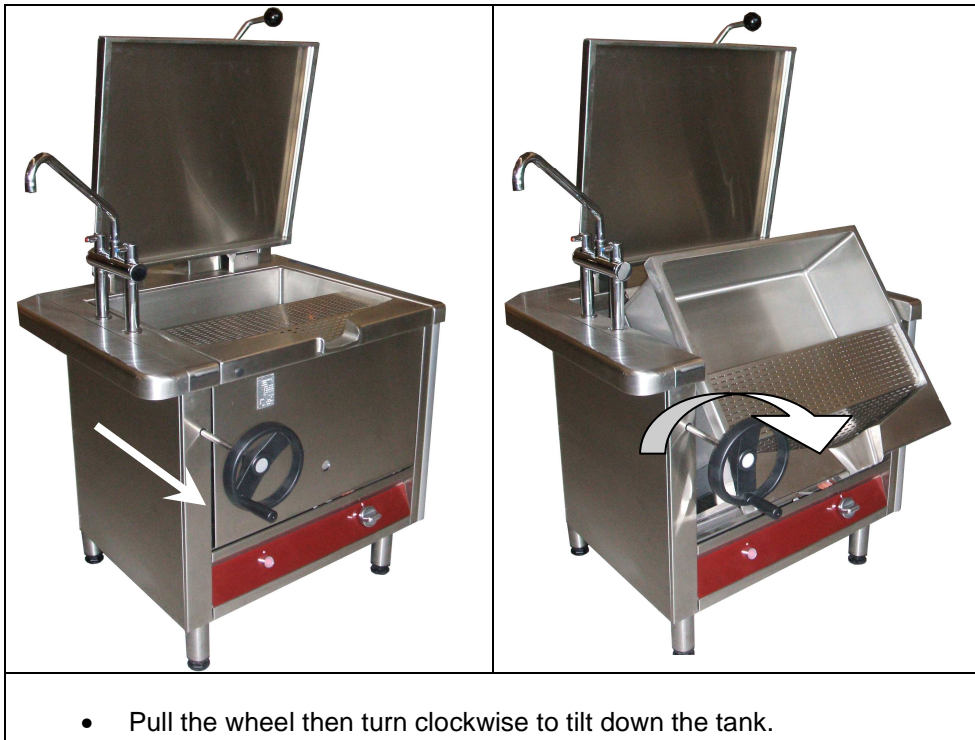

3.3. Fitting the removable s/s draining board (in option ref. V02489)

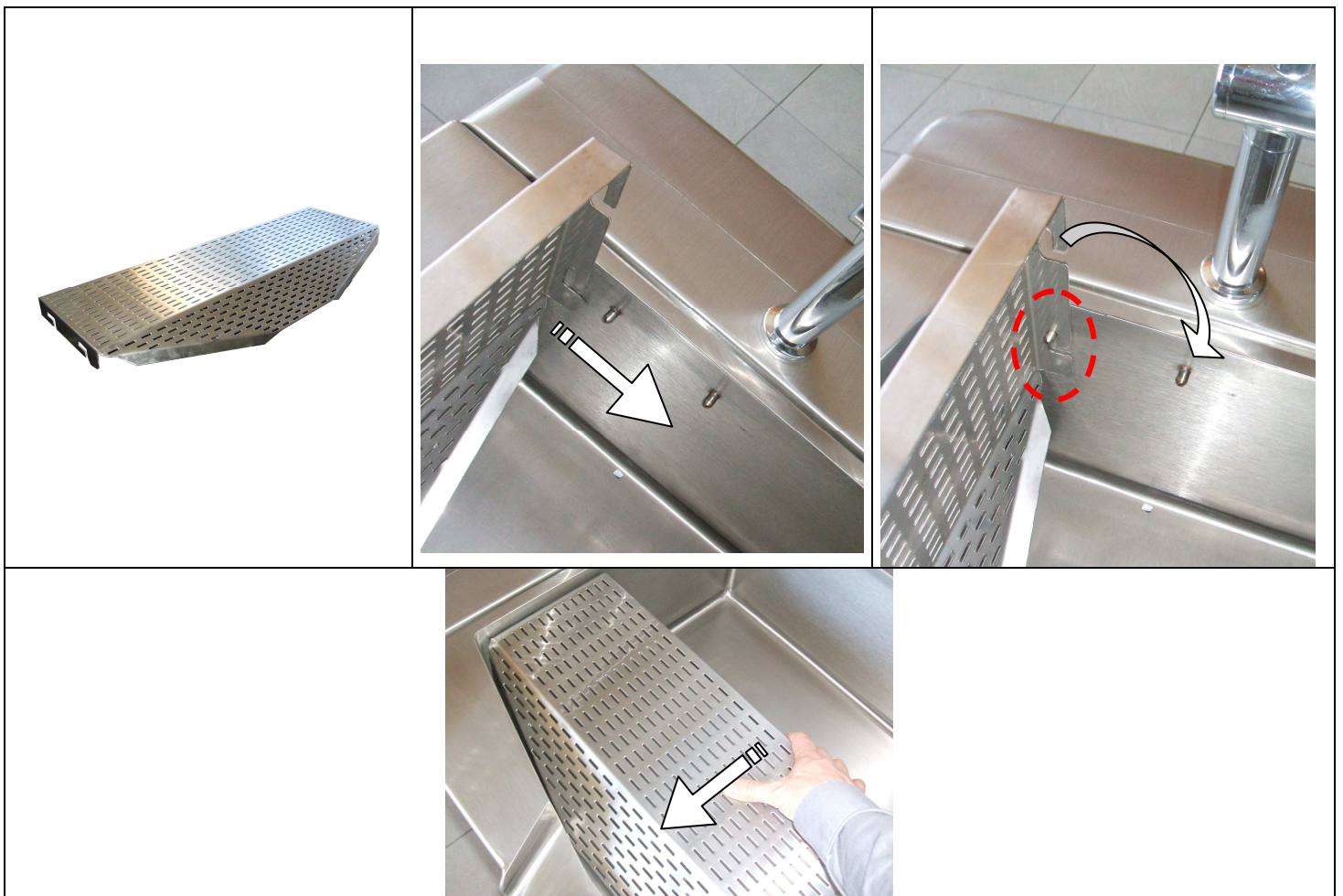

WARNING: When opening the lid during “wet” cooking operations, be careful of steam escaping to avoid any risk of burning as the arm passes over the tank.

When emptying:

- ***Stay clear of the cooked product pouring zone: risk of splash burns.***
- ***Move with the tank to control pouring in the spout area.***
- ***Tilt backward the tank to its idle position to avoid spillage of products when changing receiver containers.***

The tank sides may be very hot after an intensive and long period of use; only use the tilting wheel/handle to tilt the tank.

4. SWITCHING OFF

Bring the thermostat knob back to the position = ●
Before doing anything on the appliance, wait until cooking areas has cooled down.
Clean the tank carefully after each use (to remove all residues and liquids, and avoid rusting).

At the end of the day, switch off electricity at the mains.

5. MAINTENANCE

5.1. Cleaning of the stainless steel surfaces:

- a) Switch off the appliance,
- b) Wait until the apparatus has cooled down before doing anything on it.
- c) Wash with a sponge in soapy water (or any other neutral cleaning product).

Do not use bleach or any other acidic product – even well diluted.

For the tops, use a nylon scouring pad if necessary. Always go with the grain.

- d) After each cleaning, rub with a greased cloth or kitchen paper.
- e) Finger marks can be removed with a cloth dabbed with alcohol.

5.2. Cleaning the tank

This cleaning can be done by soaking, with soapy water.

If coarse salt is poured into the tank, rinse thoroughly the bottom of the tank with clear water to remove all salt particles. Otherwise, it will corrode the stainless steel tank.

5.3. Cleaning the burner

Please call for a qualified technician.

**This appliance must not be cleaned with mechanical water jets or be subject to a deluge of water under pressure.
Check that the appliance is well disconnected at the mains.**

For best results, have your equipment serviced and cleaned on a regular basis by a qualified installer.

WARNING: Certain parts of this appliance are protected by the manufacturer, and must not be handled by the installer or the user.

6. BREAKDOWN

6.1. Unsatisfactory heating

Probable causes

Clogging of the burners, injectors, etc.

Incorrect gas pressure.

Incorrect grading of the injectors.

6.2. Faulty ignition

Clogging of the pilot lights,

Clogging of the thermocouples,

Smashed thermocouple, incorrect pilot light output and positioning, and insufficient pressure on control button.

Faulty electric ignition (option)

Call for your installer to replace the faulty electric components in preparation for a next use.







Only a qualified electrician should replace the ignition transformers.

The manufacturer and the installer cannot be held responsible if the user neglects to ask for assistance in case of breakdown.

TRANSFER below information written on the data plate of your apparatus.

This will help you with maintenance problems and spare parts.

	CHARVET S.A.		
	38850 CHARAVINES		
Réf.	<input style="width: 100%;" type="text"/>		
Code:	<input style="width: 50%;" type="text"/>	Type:	<input style="width: 50%;" type="text"/>
N°FC:	<input style="width: 50%;" type="text"/>		<input style="width: 50%;" type="text"/>
N°OF:	<input style="width: 50%;" type="text"/>	Rep.	<input style="width: 50%;" type="text"/>
Cat.	<input style="width: 50%;" type="text"/>	<input style="width: 50%;" type="text"/>	
Gaz	<input style="width: 50%;" type="text"/>	<input style="width: 50%;" type="text"/>	
P (mbar)	<input style="width: 50%;" type="text"/>	<input style="width: 50%;" type="text"/>	
ΣQ_n (kW)	<input style="width: 50%;" type="text"/>	<input style="width: 50%;" type="text"/>	
ΣV_n (m ³ /h)	<input style="width: 50%;" type="text"/>	<input style="width: 50%;" type="text"/>	
ΣM_n (kg/h)	<input style="width: 50%;" type="text"/>	<input style="width: 50%;" type="text"/>	
U	<input style="width: 50%;" type="text"/>	V	<input style="width: 50%;" type="text"/>
		Hz Ip	<input style="width: 50%;" type="text"/>
P	<input style="width: 50%;" type="text"/>	kW	<input style="width: 50%;" type="text"/>
	<input style="width: 100%;" type="text"/>		
MADE IN FRANCE			