

ELECTRIC RADIANT HOBS

Description	PRO 800 SERIES	PRO 900 SERIES
B-E4RAY/A	V02501	V02505
R-E4RAY/A	V02502	V02506
B-E2RAY/A	V02503	V02507
R-E2RAY/A	V02504	V02508



INSTALLATION MANUAL

ELECTRIC RADIANT HOBS

1. INSTALLATION

1.1. General points

Installation must be undertaken in compliance with the following instructions and with local codes and bylaws. Ensure you have a suitable and sufficient risk assessment in place.

The user's manual must be given to the user after installation.

1.2. Handling

It is imperative to leave the appliance on its wooden pallet for handling on site until the final installation.

Unpack and check the appliance for damage upon receipt.

In case of damage, mark delivery note accordingly and immediately (within 48 hours) notify the carrier by registered mail with acknowledgement of receipt. Notify your installer.

1.3. Installation

SEE technical sheets.

The appliance must be installed under a suitable mechanical extraction hood.

DO NOT INSTALL A GRIDDLE CLOSE TO AN APPLIANCE WITH RADIANT OR INDUCTION HOBS, OR INSERT A NEUTRAL WORK TOP (L: 212.5 mm at least) BETWEEN THESE 2 APPLIANCES (the joint may melt).

If the apparatus is to be installed against a wall or partition, near a piece of furniture or decorative borders, it is recommended that these are made of fireproof material.

If this is not the case, they must be protected by an approved fireproof, insulating material.

All local fire regulations must be adhered to.

If in doubt of fireproof construction of adjacent walls, distance to combustible material shall be no less than 10 cm.

- Remove all plastic protection that wraps the apparatus and accessories (drawer).
- Install the feet (they are delivered in a box kept inside the appliance).
- Adjust height to level the unit to a horizontal working plan of 900 mm.

1.4. POWER CONNECTION

Installation must be undertaken in compliance with the following instructions and with local codes and bylaws. Ensure you have a suitable and sufficient risk assessment in place.

WARNING:

Use a standardized cable (245 IEC 57 or 245 IEC 66) or other approved cable with the same characteristics.

The appliance being constantly connected to a fixed electric source, this source will have to be fitted with a suitable leakage currents protective device.



ELECTRIC RADIANT HOBS

The appliance being connected to a cable fitted with an electrical plug, the socket should be accessible at all times.

- Before connection:
 - Check that the supply voltage is compatible with the voltage of the appliance (see data plate).
 - Check that the electric network is equipped with all-pole circuit breakers having a cross section of 3 mm.

The appliance is wired at the factory according to requirements notified at the time of order.

CHANGE OF VOLTAGE:

- For the voltage of the appliance, a coupling is realized between the heating elements.
- Please consult the manufacturer.

1.5. Powering on

1.5.1. CHECKS

Before connecting the apparatus, check that:

- The supply voltage is compatible with the voltage of the apparatus,
- The cable is fixed properly,
- The connections are tight enough,
- The apparatus is well earth wired,
- The section of the cable is suitable for the power,
- The electrical equipment is properly insulated,
- The electric current requirements are compatible with the phases.

1.5.2. Adjustments

Normally, there is no adjustment to do.

2. STARTING UP

Please see the user's manual, section "Starting up"



Do not leave metal objects on the radiant hobs as they might damaged them.

Power connections:

- They are located inside the base (open base or cupboard base).
- Remove the lid of the terminal block located on the right hand side. (the lid is clipped in the terminal block).
- Thread cable through the hole of the base floor, then through the terminal block (use a wire guide).

ELECTRIC RADIANT HOBS

- Connect cable to the terminals, and follow the information written on the terminal box.

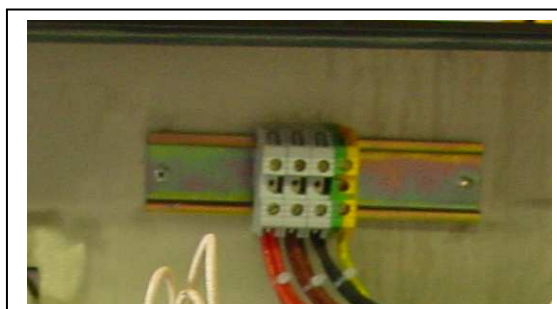

Before reassembling the parts, check the electrical equipment is properly insulated (cable).



**The appliance must be earth wired.
It is dangerous to connect the appliance unless it is earthed.**

We cannot be held responsible for accidents due to non existent or incorrect earth link connection.

WIRING DIAGRAMS:

Appliance	Voltage	Wiring diagrams #
E_RAY	3 ~ 400 V + E	SE0053 / 00
OVEN	3 ~ 400 V + E	SE0011 / 00
AUTOMATIC E_RAY	3 ~ 400 V + E	SE0054 / 00

3. SERVICING



Any technical action on an appliance must be undertaken by a qualified technician.

The appliance will have to be isolated from the electrical supply for the duration of the work, and a warning notice will be displayed.

When the appliance is ready for use, ensure the users know how to use it properly (please see the User's Manual).

Formerly give the person in charge of the kitchen all documentation needed.

ELECTRIC RADIANT HOBS

Each appliance has its own data plate.

Transfer all the information written on the data plate to the part of the User's Manual reserved for it.

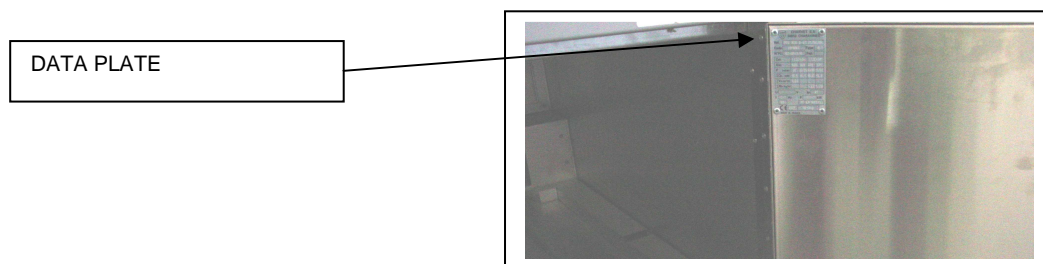





This will ease the communication between you and your client for better service.

WARRANTY:

The warranty is mentioned in our conditions of sale.

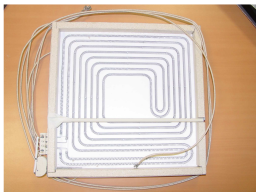
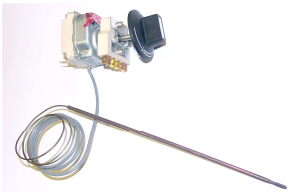
This warranty does not cover damage due to faulty installation, misuse or inadequate maintenance.

4. BASIC SPARE PARTS LIST

Description	Code	Photograph	Description	Code	Photograph
Hob 400 V, 4000 W	06295 A		Thermostat	03020 A	
Oven switch	00831 A		Red indicator Yellow indicator	07136 A 07139 A	
Heating element 2500W, 400V	02063 A		Detection device	00089 A	

ELECTRIC RADIANT HOBS

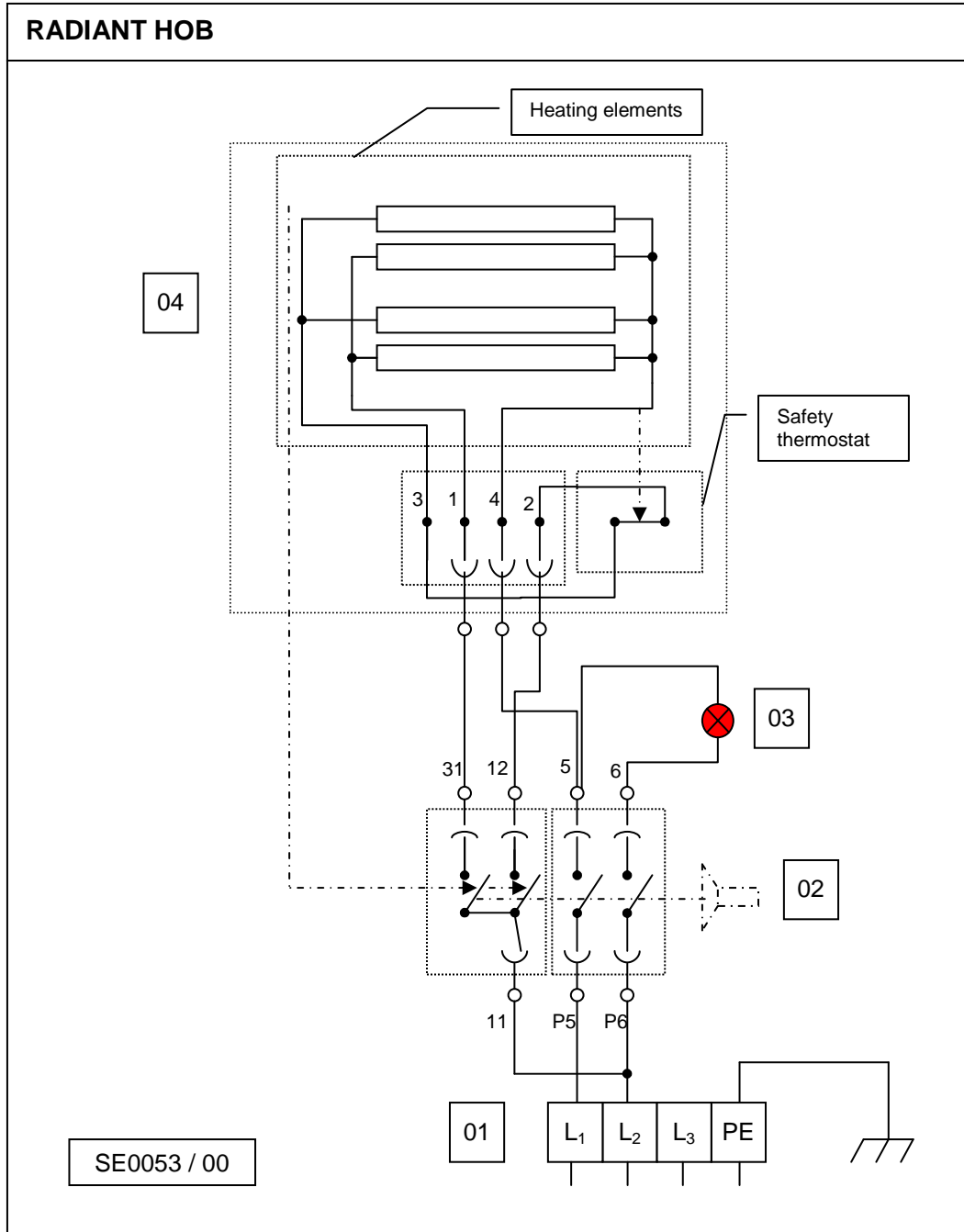

ELECTRIC RADIANT HOBS

NOMENCLATURE: 2 RADIANT HOBS (wiring diagram: SE0053 / 00)

Mark	Code	Description	Quantity
01	02468A	10 mm ² terminal (brand: Viking)	3
01	03575A	10 mm ² Earth terminal (brand: Viking)	1
02	03020A	Thermostat	2
03	02131A	Red indicator	2
04	06295A	Radiant hob	2

NOMENCLATURE: 2 RADIANT HOBS (wiring diagram: SE0053 / 00)

Mark	Code	Description	Quantity
01	02468A	10 mm ² terminal (brand: Viking)	3
01	03575A	10 mm ² Earth terminal (brand: Viking)	1
02	03020A	Thermostat	4
03	07136A	Red indicator	4
04	06295A	Radiant hob	4



ELECTRIC RADIANT HOBS

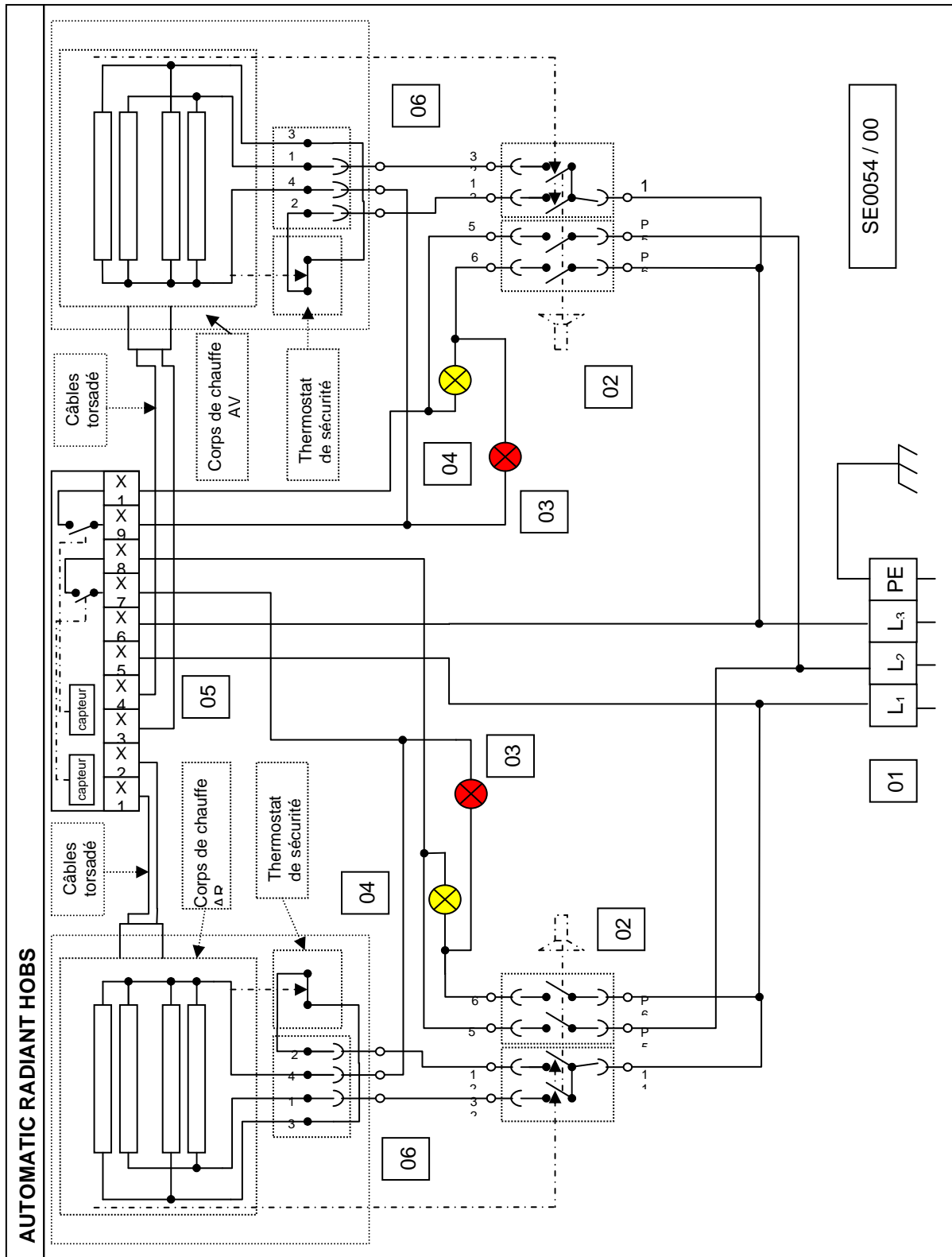

ELECTRIC RADIANT HOBS

NOMENCLATURE: 2 AUTOMATIC RADIANT HOBS (wiring diagram: SE0054 / 00)

Mark	Code	Description	Quantity
01	02468A	10 mm ² terminal (brand: Viking)	3
01	03575A	10 mm ² Earth terminal (brand: Viking)	1
02	03020A	Thermostat	2
03	07136A	Red indicator (heat indicator)	2
04	07139A	Yellow indicator (ON indicator)	2
05	00089A	Detection device	1
06	00090A	Automatic radiant hob - 4000 W, 400 V	2

NOMENCLATURE: 4 AUTOMATIC RADIANT HOBS (wiring diagram: SE0054 / 00)

Mark	Code	Description	Quantity
01	02468A	10 mm ² terminal (brand: Viking)	3
01	03575A	10 mm ² Earth terminal (brand: Viking)	1
02	03020A	Thermostat	4
03	07136A	Red indicator (heat indicator)	4
04	07139A	Yellow indicator (ON indicator)	4
05	00089A	Detection device	2
06	00090A	Automatic radiant hob – 4000 W, 400 V	4



ELECTRIC RADIANT HOBS

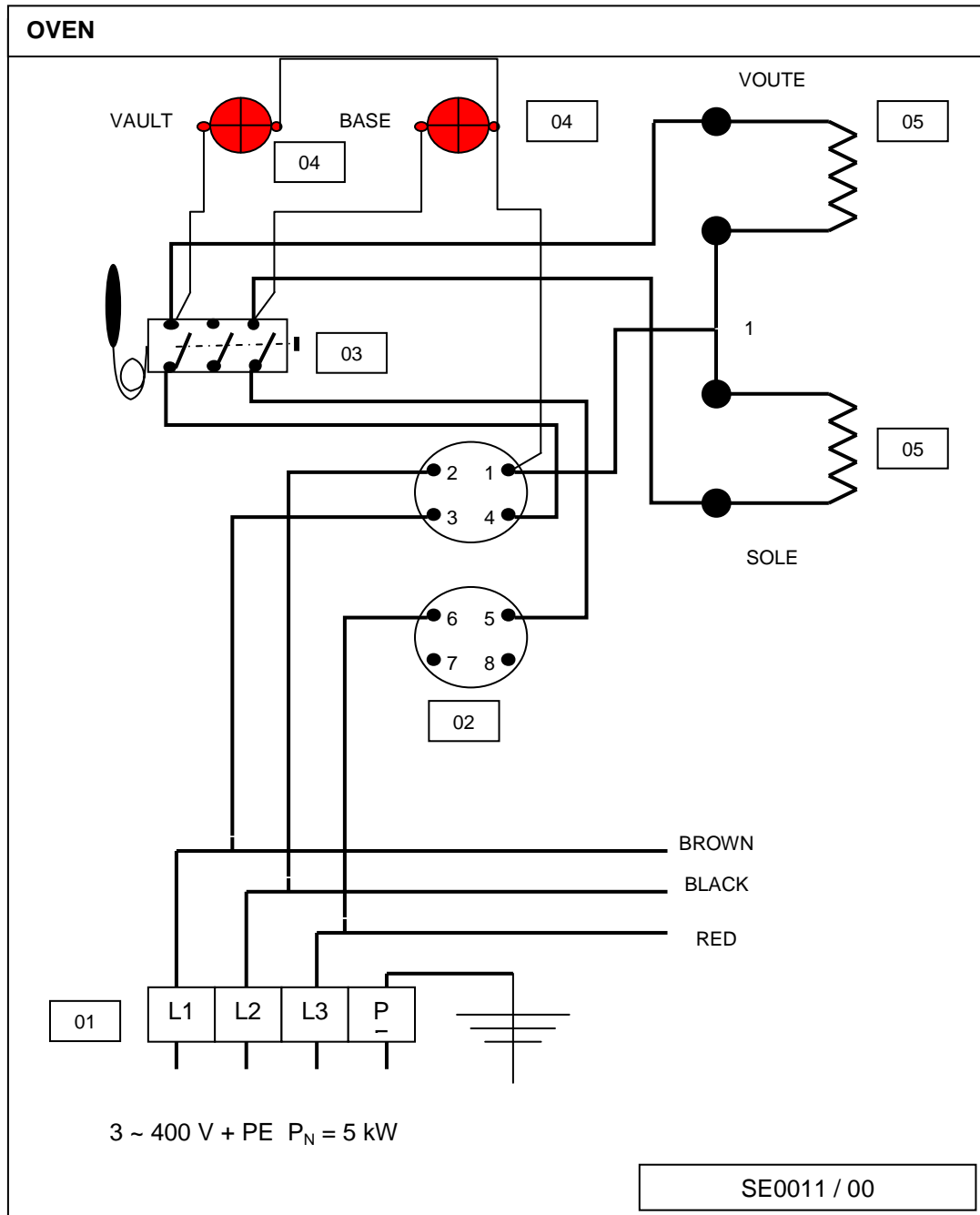

NOMENCLATURE: ELECTRIC OVEN (wiring diagram: SE0011 / 00)

Mark	Code	Description	Quantity
01	02473A	16 mm ² terminal (brand: Viking)	3
01	02471A	16 mm ² Earth terminal (brand: Viking)	1
02	00831A	Oven switch	1
03	01990A	Thermostat 50-300°C	1
03	07136A	Red indicator	2
05	02063A	Heating element 2500 W, 400 V	2

ELECTRIC RADIANT HOBS

Description	PRO 800 SERIES	PRO 900 SERIES
B-E4RAY/A	V02501	V02505
R-E4RAY/A	V02502	V02506
B-E2RAY/A	V02503	V02507
R-E2RAY/A	V02504	V02508



User's Instructions

ELECTRIC RADIANT HOBS

1. INTRODUCTION

- A) Our equipment is for professional use only and must be used by qualified staff.
- B) The equipment must be installed in compliance with local codes and bylaws. It must be installed in a kitchen equipped with an adequately sized mechanical extraction system.
- C) Appliances may be installed side by side or against walls of non combustible material. Distance to combustible material shall be no less than 10 cm.
- D) It is imperative to call for a qualified engineer for all new installations or modifications of existing equipment.
- E) This instruction manual is contractual and must be given to the user after installation.
- F) **WARRANTY:** *The warranty is mentioned in our conditions of sale. Only a qualified engineer certifies the validity of the warranty. This warranty does not cover damage due to faulty installation, misuse or inadequate maintenance.*

Dimensions:

Full module unit:

Length: 850 mm.
Depth: 800 mm.
Height: 900 mm.

Half module unit:

Length: 425 mm.
Depth: 800 mm.
Height: 900 mm.

Specification:

One-piece seam welded 18-10 stainless steel chassis, 1 to 3 mm thick.
18-10 stainless steel top frame, 2-mm thick, with a 55-mm high edge having a 18 mm radius and return to underside.
18-10 stainless steel side panels, 1-mm thick; assembly with no visible screws.
Controls on enameled steel panels with control symbol markings.
18-10 stainless steel legs, 200-mm high, with adjustable PVC feet, diameter 60.3 mm, adjustment +10/-20.

Top:

Set of 2 radiant hobs:

Hobs measuring 300 x 300 mm under a silkscreen ceramic surface measuring 360 x 620 x 6 mm.

Rated 2 x 4 kW – voltage: 3 ~ 400 V + E.
Switches.
ON and heat indicators.
Safety thermostat

Base:

Electric static oven (L: 530 mm x D: 650 mm x H: 300 mm) ->

Heating elements 3 ~ 400 V + E (mild steel base and vault) – rated 5 kW in total.
4-position switch: vault – 0 – mild steel base – 0 – vault + mild steel base (minimum setting) – 0 – vault + mild steel base (maximum setting) – 0 – regulation thermostat 50-350°C – indicators -
Mild steel base, 4-mm thick.



ELECTRIC RADIANT HOBS

Stainless steel muffle with thermal insulating board.

Removable 3-position enameled steel shelf runners with a distance of 70 mm between each runner.

18-10 stainless oven door with thermal insulating board - handle in enamelled steel on aluminium supports.

Open base:

18-10 stainless steel removable floor (2-part floor for full module units, and 1-part floor for half-module unit).

Options:

Electric hot cupboard GN 2/1 or GN 1/1 (in open base).

Front hinged door(s) (for open base).

Set of 2 pan detectors (for 2 radiant hobs).

2. PRIOR TO STARTING UP

Prior to starting up, it is advisable to clean the appliance in order to eliminate all dust and impurities that have accumulated during storage.

Remove all plastic protection that wraps the stainless steel panels.

Make sure that all controls are in good working condition.

Before each use, protect the top with a suitable product against sweet foods, food particles, overflows, stagnant liquids, etc.

Turn on the power.

3. STARTING UP

The appliance is ON:

Turn control knob to the desired position: the red indicator is alight meaning that the radiant hob is heating.

Cooking temperatures will be reached after a few minutes of heating process.



PRACTICAL ADVICE

These radiant hobs are suitable for cooking and simmering various foods.

4000 W of power is what you get when the control knob is on position 3. The appliance is fitted with an overheating safety cut out device.

Powers available:

. Position 1: 1000 W

. Position 2: 2000 W

. Position 3: 4000 W

As the temperature increases rapidly, stay on position 1 during idle time and on position 3 during service so the radiant hobs will last longer.

ELECTRIC RADIANT HOBS



The top and the sides of the appliance can be very hot after prolonged and intensive use.

4. SWITCHING OFF

Bring control knob to position 0.



The top and sides remain very hot even after having turned off the appliance.

At the end of the day, switch off electricity at the mains.

5. MAINTENANCE

5.1. Cleaning the stainless steel surfaces

Wash with a sponge in soapy water (or any other neutral cleaning product).

Do not use bleach or any other acidic product – even well diluted.

For the tops, use a nylon scouring pad if necessary. Always go with the grain.

After each cleaning, rub with a greased cloth or kitchen paper.

Finger marks can be removed with a cloth dabbed with alcohol.

5.2. Cleaning the glass-ceramic cooktop

- a) Turn off.
- b) Remove all food residues and dirt with a suitable cleaning tool (scraper).
- c) When the cooking top has cooled down, clean with a suitable cleaning product and household roll towel (or similar).
- d) Rinse with clear water, and dry with a piece of cloth.

Withdraw all metal objects from the cooking top before use.

This appliance must not be cleaned with mechanical water jets or be subject to a deluge of water under pressure.

Check that the appliance is well disconnected at the mains.



ELECTRIC RADIANT HOBS

For best results, have your equipment serviced and cleaned on a regular basis by a qualified installer.

WARNING: Factory-sealed components must be serviced by neither installer nor user.

6. IN CASE OF BREAKDOWN

UNSATISFACTORY HEATING: Probable causes

- The indicator is alight but the radiant hob is not heating: Hob disconnected.
- The indicator does not alight:
 - . The ceramic hob is heating up = the bulb may have blown,
 - . The radiant hob is not heating up = faulty switch.

Contact the supplier to replace the faulty parts for further use.







Only a qualified electrician can replace the faulty electric parts (switch, radiant hob).

The manufacturer and the installer cannot be held responsible if the user neglects to ask for assistance in case of breakdown.

ELECTRIC RADIANT HOBS

DATA PLATE OF YOUR APPLIANCE

This will help you with maintenance problems and spare parts.

	CHARVET S.A.		
	38850 CHARAVINES		
Réf.	<input style="width: 100%;" type="text"/>		
Code:	<input style="width: 50%;" type="text"/>	Type:	<input style="width: 50%;" type="text"/>
N°FC:	<input style="width: 50%;" type="text"/>		<input style="width: 50%;" type="text"/>
N°OF:	<input style="width: 50%;" type="text"/>	Rep.	<input style="width: 50%;" type="text"/>
Cat.	<input style="width: 50%;" type="text"/>	<input style="width: 50%;" type="text"/>	
Gaz	<input style="width: 50%;" type="text"/>	<input style="width: 50%;" type="text"/>	<input style="width: 50%;" type="text"/>
P (mbar)	<input style="width: 50%;" type="text"/>	<input style="width: 50%;" type="text"/>	<input style="width: 50%;" type="text"/>
ΣQ_n (kW)	<input style="width: 50%;" type="text"/>	<input style="width: 50%;" type="text"/>	<input style="width: 50%;" type="text"/>
ΣV_n (m ³ /h)	<input style="width: 50%;" type="text"/>	<input style="width: 50%;" type="text"/>	<input style="width: 50%;" type="text"/>
ΣM_n (kg/h)	<input style="width: 50%;" type="text"/>	<input style="width: 50%;" type="text"/>	<input style="width: 50%;" type="text"/>
U	<input style="width: 50%;" type="text"/>	V	<input style="width: 50%;" type="text"/>
		Hz Ip	<input style="width: 50%;" type="text"/>
P	<input style="width: 50%;" type="text"/>	kW	<input style="width: 50%;" type="text"/>
	<input style="width: 100%;" type="text"/>		
MADE IN FRANCE			

