



4 ELECTRIC PLATES E300

Description	PRO 800 SERIES	PRO 900 SERIES
E300	V01653	V01959
B-E300	V01654	V01960
R-E300	V01655	V01961
½ B-E300	V01938	V01981
½ R-E300	V01672	V01982



INSTALLATION MANUAL

CHARVET

F-38850 – CHARAVINES
Tel. : +33 (0) 4 76 06 64 22
Fax : +33 (0) 4 76 55 78 75
Email : info@charvet.fr
Email : sav@charvet-sa-fr



MANUAL: 800-900 E300 ;
Index A – Created on: 14/04/2011

Code of manual: F800N / 110UK

SUMMARY

INSTALLATION MANUAL	1
1. INSTALLATION	3
1.1. General points.....	3
1.2. Handling.....	3
1.3. Installation	3
2. POWER CONNECTION	4
2.1. Checks before proceeding	5
2.2. Connecting the appliance to the main electrical supply.	5
2.3. Checks after connecting	6
2.4. Adapting the appliance to the various electrical supplies voltage	6
3. WIRING DIAGRAMS	6
4. BASIC SPARE PARTS LIST	13

1. INSTALLATION

1.1. General points

Installation must be undertaken in compliance with the following instructions and with local codes and bylaws. Ensure you have a suitable and sufficient risk assessment in place.

The user's manual must be given to the user after installation.

1.2. Handling

It is imperative to leave the appliance on its wooden pallet for handling on site until the final installation.

Unpack and check the appliance for damage upon receipt.

In case of damage, mark delivery note accordingly and immediately (within 48 hours) notify the carrier by registered mail with acknowledgement of receipt. Notify your installer.

1.3. Installation

All local fire regulations must be adhered to.

The appliance must be installed under a suitable mechanical extraction hood, close to the electric supply.

If the apparatus is to be installed against a wall or partition, near a piece of furniture or decorative borders, it is recommended that these are made of fireproof material.

If this is not the case, they must be protected by an approved fireproof, insulating material.

If in doubt of fireproof construction of adjacent walls, distance to combustible material shall be no less than 10 cm.

Remove all plastic protection.

Install the appliance in the kitchen.

Warnings



• Fixed appliance:

Install the feet or the leveling studs (they are delivered in a box kept inside the appliance).
Adjust height to level the unit to a horizontal working plan of 900 mm.

• Mobile appliance:

Install the castors (they are delivered in a box kept inside the appliance).
The castors with brakes must be locked when the appliance is being connected and during cooking times.
Fix all independent half module against the wall.

SERVICING

**Any technical action on an appliance must be undertaken by a qualified technician.
The appliance will have to be isolated from the electrical supply for the duration of the work.**

When the appliance is ready for use, ensure the users know how to use it properly.
(Please see the user's manual.)



WARRANTY: The warranty is mentioned in our conditions of sale.

This warranty does not cover damage due to faulty installation, misuse or inadequate maintenance.

- **Data plate**

Each appliance has its own data plate. Transfer all the information written on the data plate to the part of the user instructions booklet reserved for it. (See the last page of the User's Manual.)

This will ease the communication between you and your client for better service.

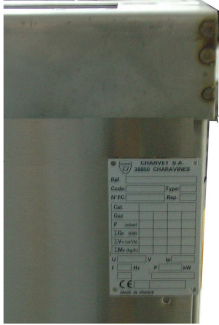
		
<p>The data plate is on the oven door</p>	<p>The data plate is inside cupboard B-E300</p>	<p>The data plate is on the front R-E300</p>

2. POWER CONNECTION

Warnings:

The appliance must be earth wired.
It is dangerous to connect the appliance unless it is earthed.
We cannot be held responsible for accidents due to non existent or incorrect earth link connection.

- **Fixed and mobile appliance:**

Check that the electric network is equipped with all-pole circuit breakers having a cross section of 3.5 mm, and complies with the European Standard EN 60335-1 dated of May.

- **Mobile appliance:**

The appliance being connected to a cable fitted with an electrical plug, the socket should be accessible at all times.

- **WARNING:**

Use a standardized cable (245 IEC 57 or 245 IEC 66) or other approved cable with the same characteristics.

All controls and checks below are done when the appliance is switched off and cold.

2.1. **Checks before proceeding**

- The electrical voltage of the supply is compatible with the voltage of the apparatus (see § 2.4.).
- The cable is fixed properly,
- The connections are tight enough,
- The section of the cable is of correct size according to the voltage of the apparatus.

2.2. **Connecting the appliance to the main electrical supply.**

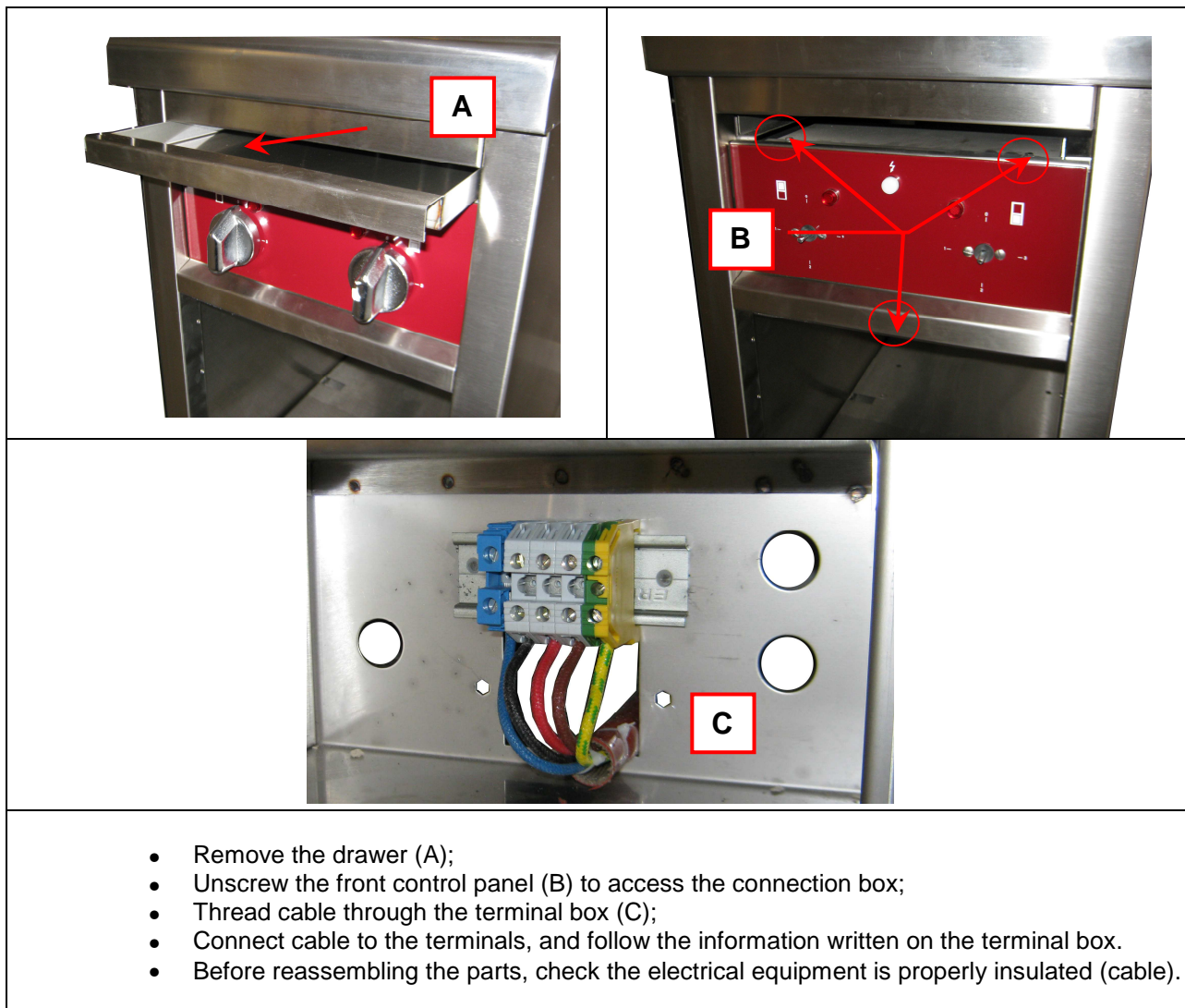

2.3. **Checks after connecting**

- The appliance is well earth wired (see the warnings);
- The equipment is well isolated;
- The appliance is in good working conditions.

STARTING UP: See the User's Manual – Section "Starting up"

2.4. **Adapting the appliance to the various electrical supplies voltage**

<i>Voltage</i>					
<i>Voltages of the Apparatus delivered</i>	1~230V + E	3~230V + E	3~400V+N+E	3~400V + E	3~440V+E
E300 4 electric plates		A		A	A
Electric diagram		SE0061/01		SE0008/01	SE0067/01
Electric oven	A			A	A
Electric diagram	SE0062/01			SE0011/01	SE0063/01

A → Coupling possible B→ Please consult Charvet C → Coupling impossible D → No voltage available

3. WIRING DIAGRAMS

Legend

FRENCH	ENGLISH
AR GA	REAR – LEFT
AR DR	REAR – RIGHT
AV GA	FRONT – LEFT
AV DR	FRONT – RIGHT
Brun	Brown
Rouge	Red
Noir	Black
Sole	Mild steel base
Voûte	Vault

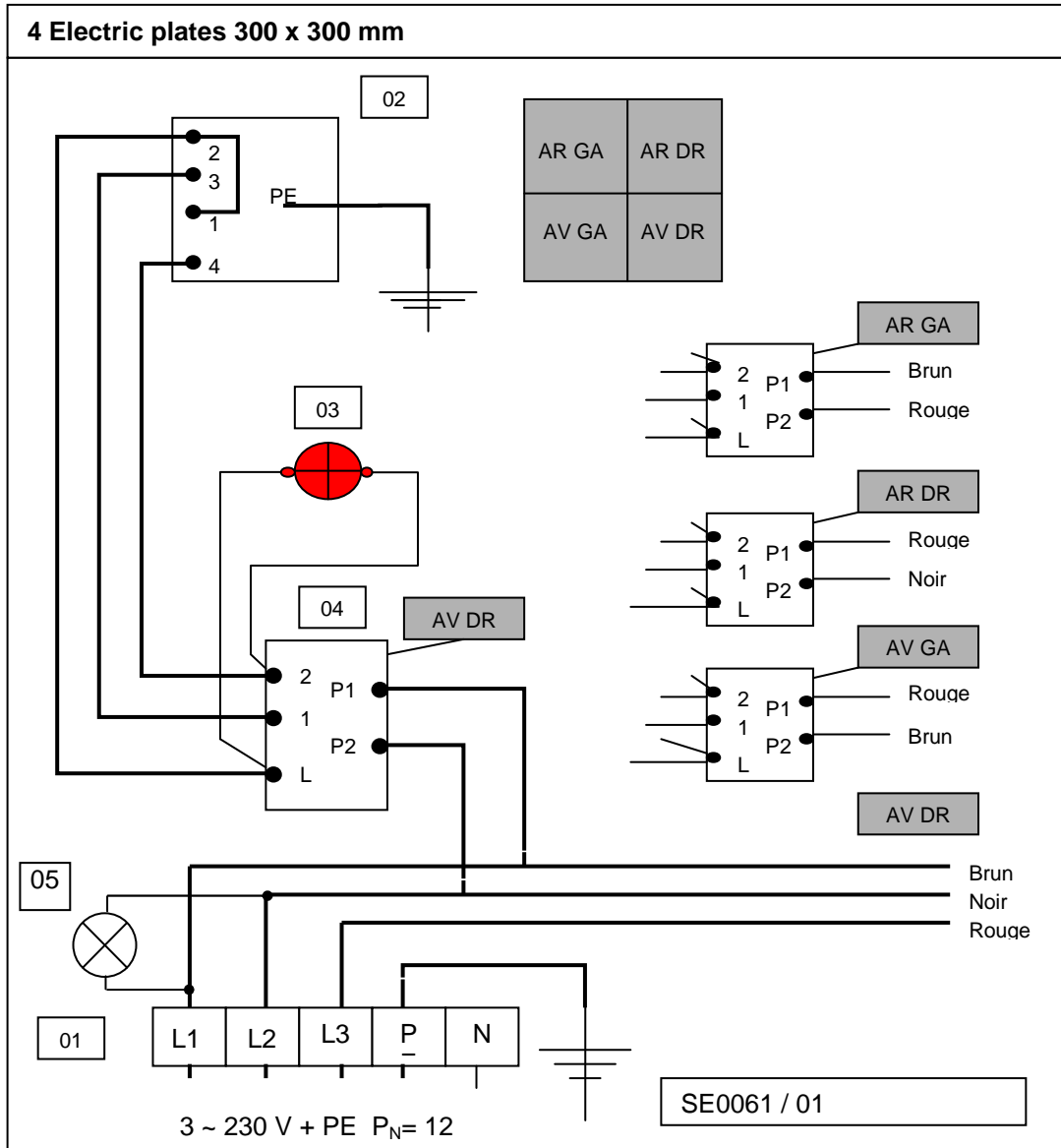

NOMENCLATURE: Electric plate 300 x 300 mm – 3-400 V + E (drawing: SE0061 / 01)

Mark	Reference	Description	Quantity
01	02468A	10 mm ² terminal (brand: Viking)	3
01	03575A	10 mm ² Earth terminal (brand: Viking)	1
02	06128A	Electric plate 400 mm x 400 mm - 3000 W - 400 V	4
03	02131A	High-temperature red indicator	4
03	02141A	Bulb for indicator 230 V	4
04	02093A	Switch	4
04	02095A	Control knob	4
05	08153A	White indicator 400V	1

WARNING!

In case of voltage change, connect terminals P1 of switches to the neutral terminal, and terminals P2 to a network phase.

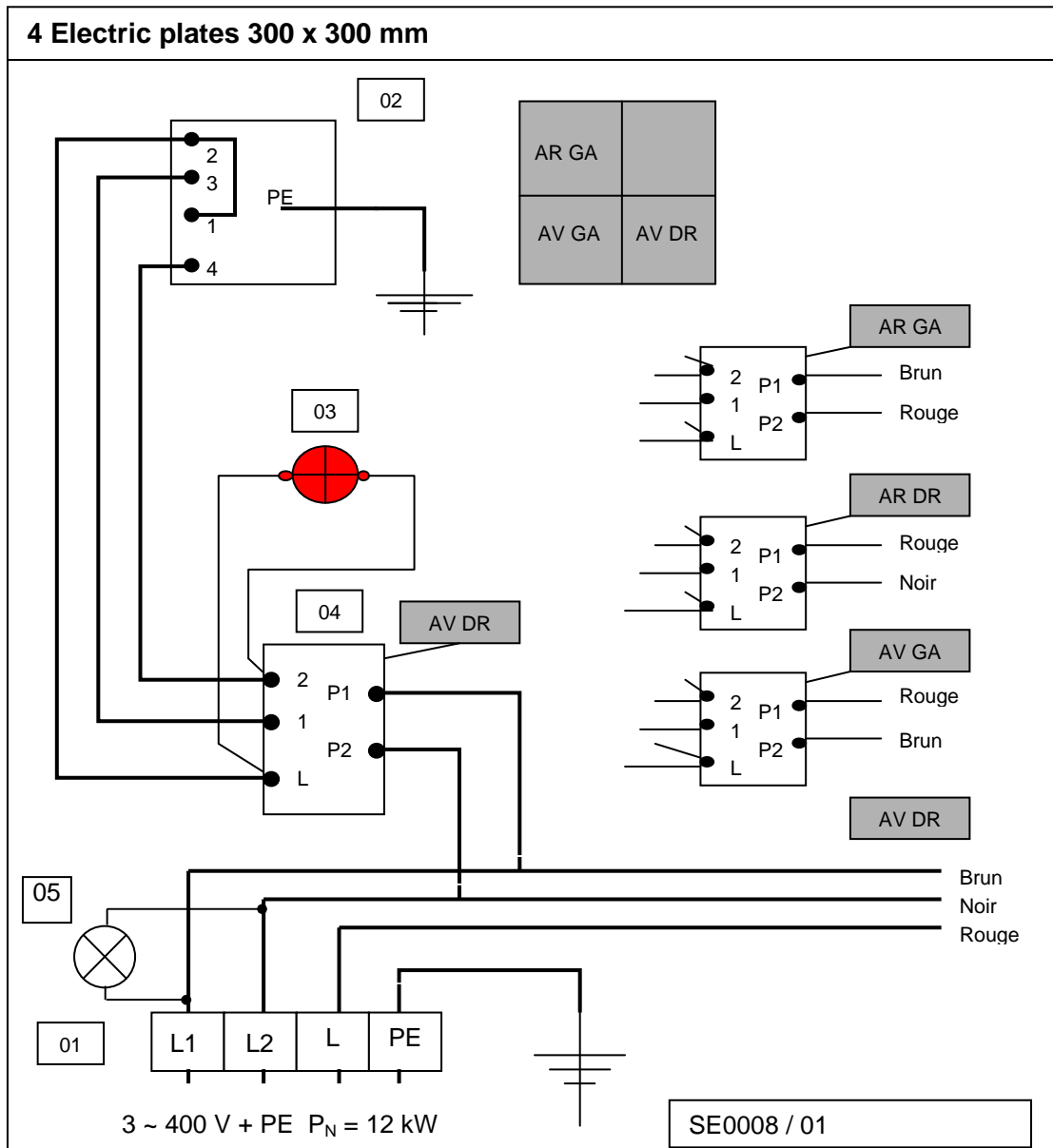

NOMENCLATURE: Electric plate 300 x 300 mm – 3-400 V (drawing: SE0008 / 01)

Mark	Reference	Description	Quantity
01	02468A	10 mm ² terminal (brand: Viking)	3
01	03575A	10 mm ² Earth terminal (brand: Viking)	1
02	06048A	Electric plate 300 mm x 300mm mm - 3000 W - 400 V	4
03	02131A	Red indicator	4
03	02142A	Bulb 400 V	4
04	02093A	Switch	4
04	02095A	Control knob	4
05	08153A	White indicator 400V	1

4 Electric plates 300x 300 mm

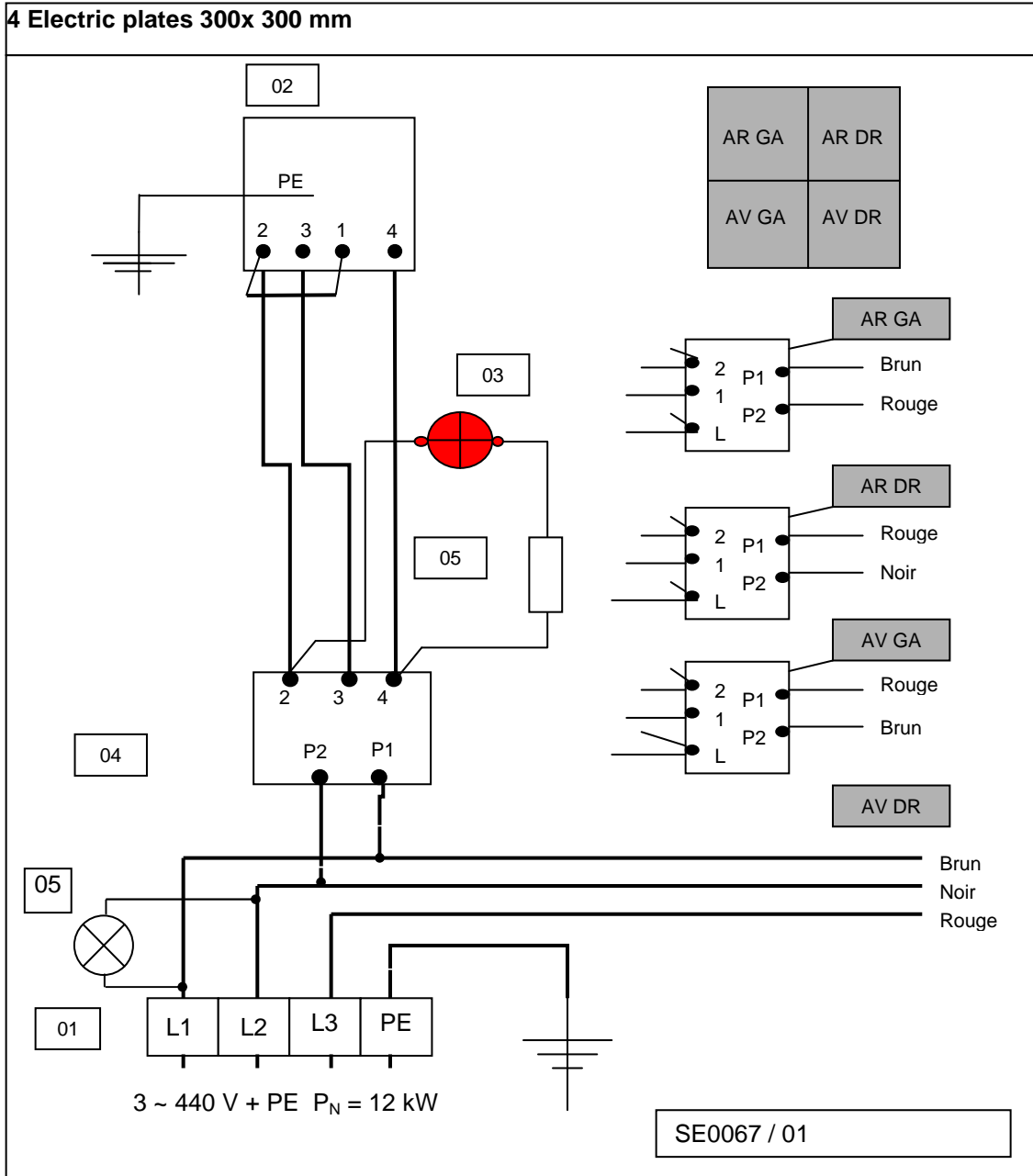

NOMENCLATURE: Electric plate 300 x 300 mm – 3-440 V (drawing: SE0067 / 01)

Mark	Reference	Description	Quantity
01	02468A	10 mm ² terminal (brand: Viking)	3
01	03575A	10 mm ² Earth terminal (brand: Viking)	1
02	06198A	Electric plate 300 mm x 300 mm - 3000 W - 440 V	4
03	02131A	Red indicator	4
03	02142A	Bulb 400 V	4
04	02093A	Switch	4
05	02145A	Heating element 68 kΩ	4
06	08153A	White indicator 400V	1

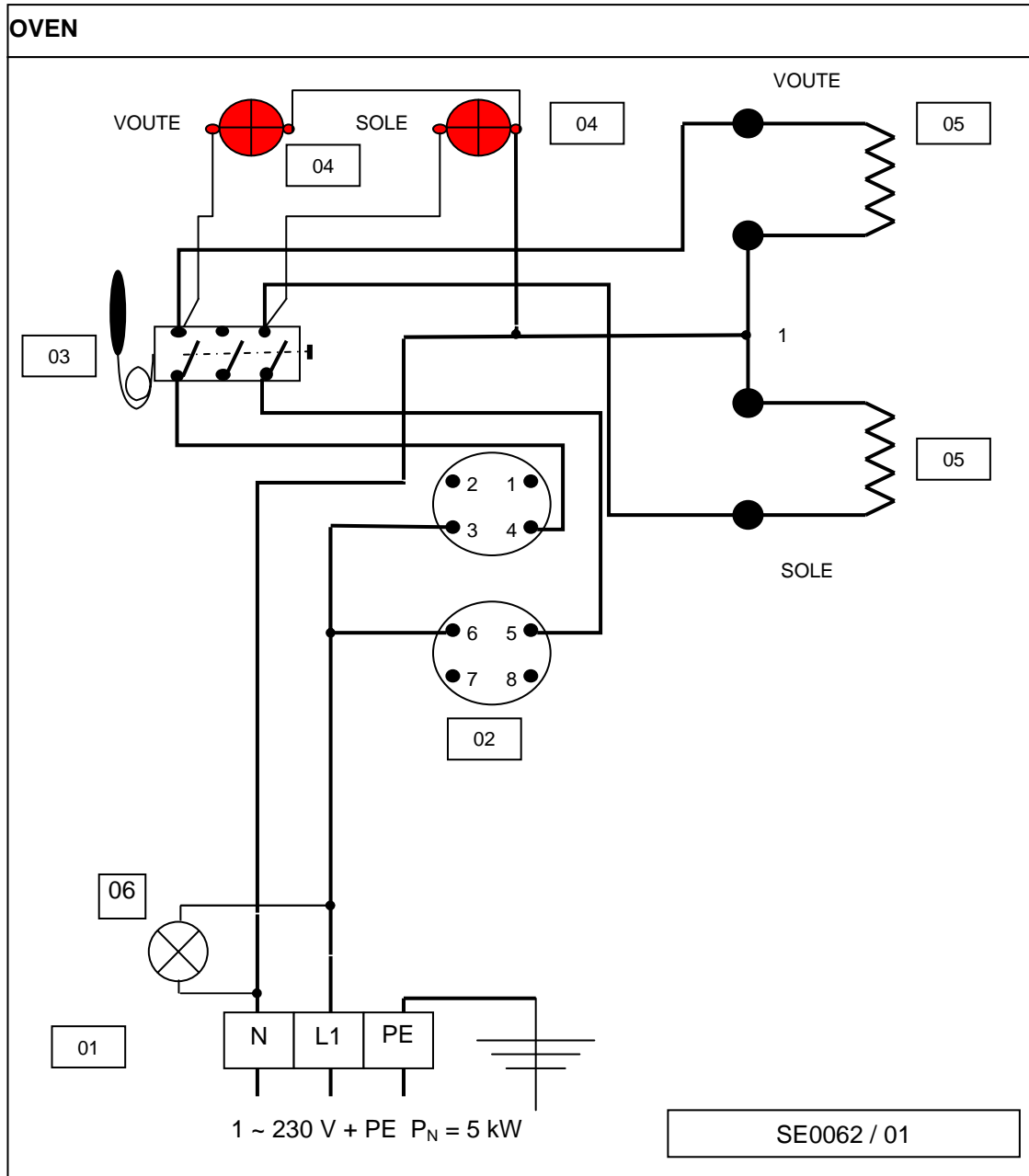

NOMENCLATURE: ELECTRIC OVEN 1-230 V (wiring diagram: SE0062 / 01)

Mark	Code	Description	Quantity
01	02468A	10 mm ² terminal (brand: Viking)	1
01	07069A	Blue terminal Vicking	1
01	03575A	Earth terminal (brand: Viking)	1
02	00831A	Oven switch	1
03	01990A	Thermostat 50°C-300°C	1
04	02131A	Red indicator	2
04	02141A	Bulb 230 V	2
05	02062A	Heating element 2500 W, 230 V for oven	2
06	08153A	White indicator 400V	1

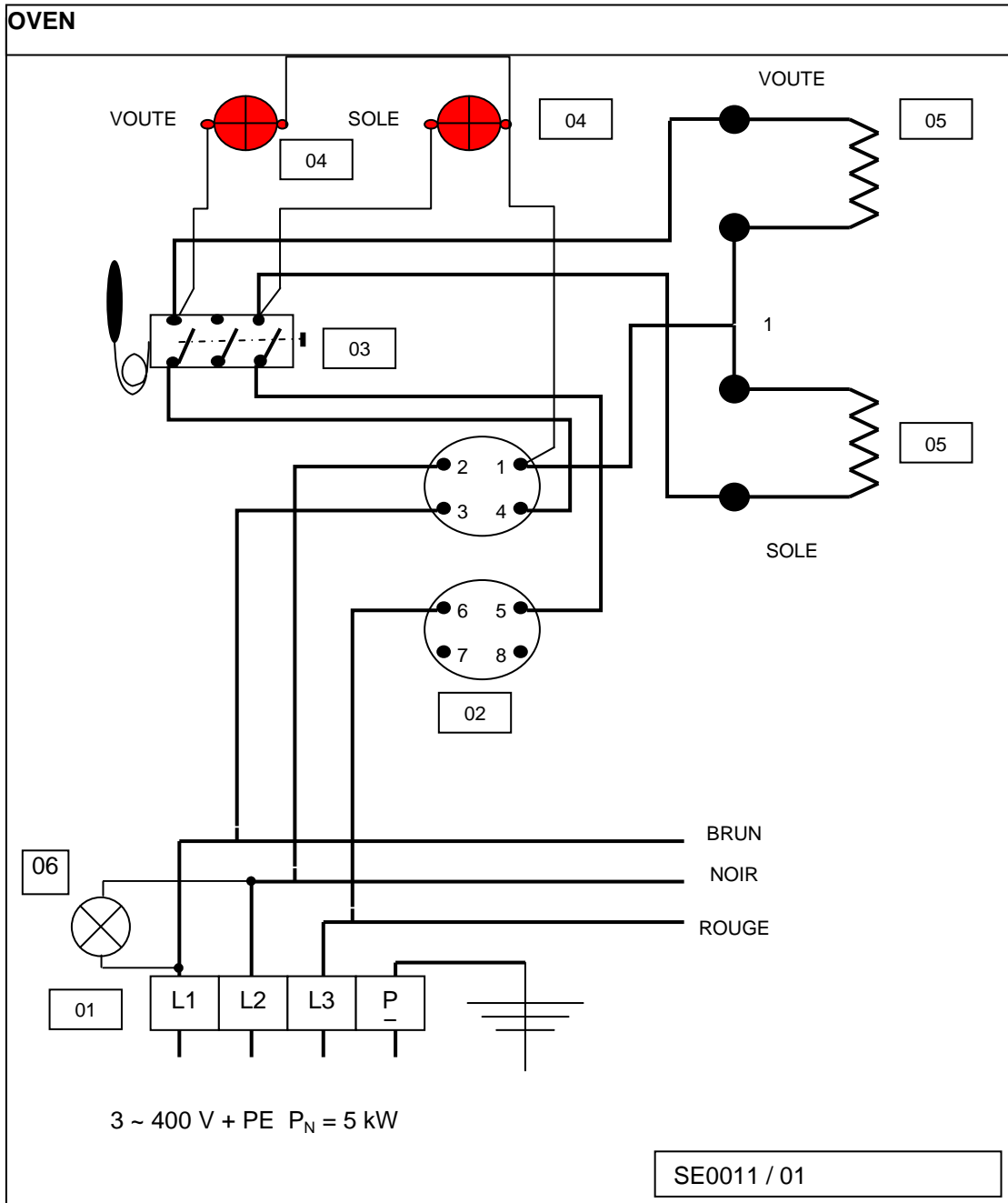

NOMENCLATURE: ELECTRIC OVEN 3~400 V (wiring diagram: SE0011 / 01)



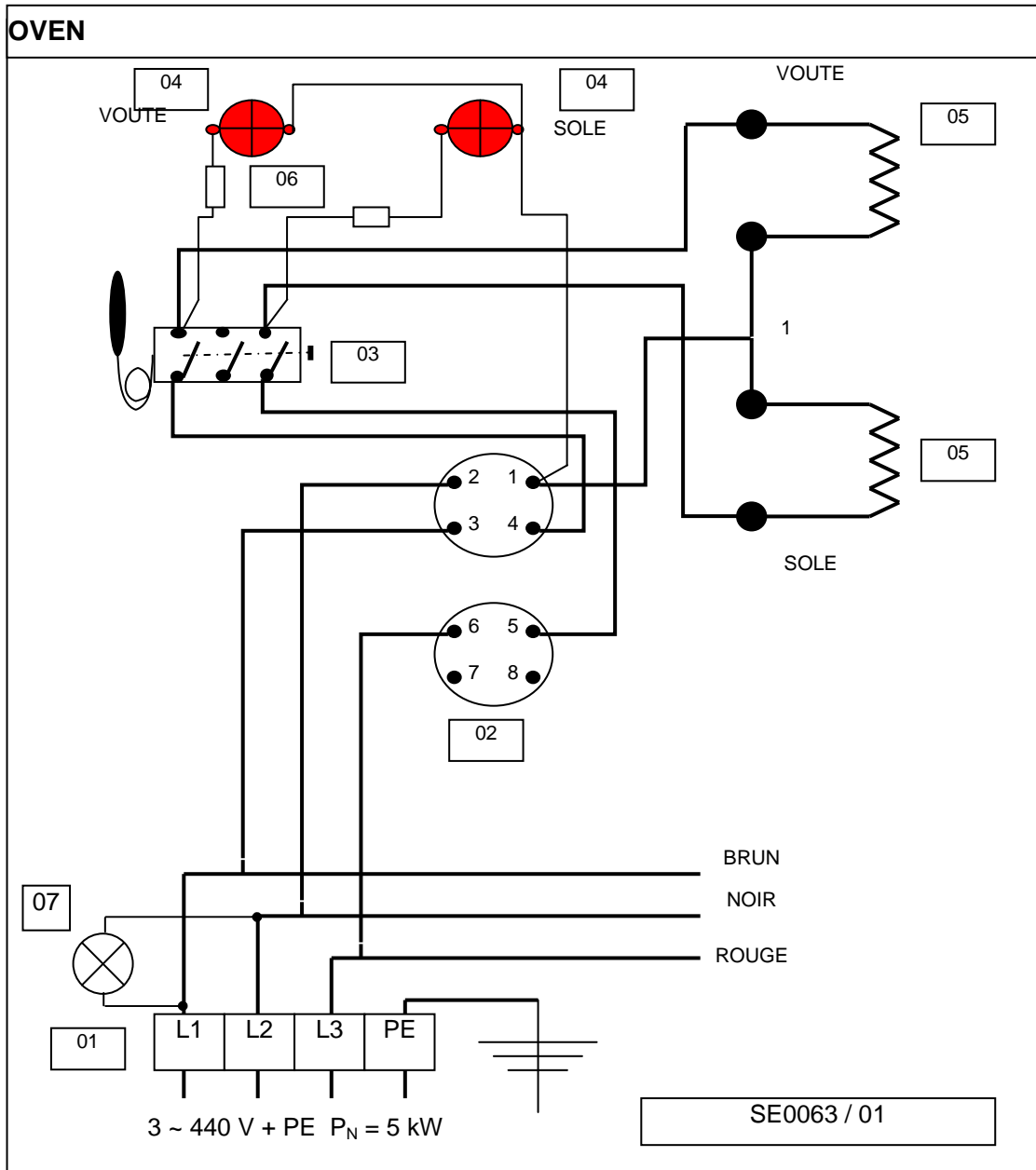



Mark	Code	Description	Quantity
01	02473A	16 mm ² terminal (brand: Viking)	3
01	02471A	16 mm ² Earth terminal (brand: Viking)	1
02	00831A	Oven switch	1
03	01990A	Thermostat 50-300°C	1
04	02131A	Red indicator	2
04	02142A	Bulb 400 V	2
05	02063A	Heating element 2500 W, 400 V	2
06	08153A	White indicator 400V	1

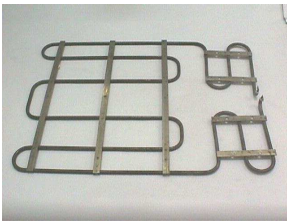

NOMENCLATURE: ELECTRIC OVEN 3~440 V (wiring diagram: SE0063 / 01)

Mark	Code	Description	Quantity
01	02473A	16 mm ² terminal (brand: Viking)	3
01	02471A	16 mm ² Earth terminal (brand: Viking)	1
02	00831A	Switch	1
03	01990A	Thermostat 50°C–300°C	1
04	02131A	Red indicator	2
04	02142A	Bulb 400 V	2
05	02064A	Heating element 440 V, 2500 W	2
06	02145A	Heating element 68 kΩ (for indicator)	2
07	08153A	White indicator 400V	1

4. BASIC SPARE PARTS LIST

Description	Code	Photograph	Description	Code	Photograph
Electric plate 300 x 300 mm - 3000 W 400 V 440 V 230 V	06048A 06198A 02071A		Switch	02093A	
Heating element 2500W W, 400 V 230 V 440 V	02063A 02062A 02064A		Oven switch	00831A	
White indicator 400 V	08153A		Tripolar thermostat 50-300°C	01990A	
Red indicator 400 V 230V	07136A 07137A				



4 ELECTRIC PLATES E300

Description	PRO 800 SERIES	PRO 900 SERIES
E300	V01653	V01959
B-E300	V01654	V01960
R-E300	V01655	V01961
½ B-E300	V01938	V01981
½ R-E300	V01672	V01982



USER'S INSTRUCTIONS

CHARVET

F-38850 – CHARAVINES
Tel. : +33 (0) 4 76 06 64 22
Fax : +33 (0) 4 76 55 78 75
Email : info@charvet.fr
Email : sav@charvet-sa-fr



MANUAL: 800-900 E300
Index A – Created on: 14-04-2011

Code of manual: F800N / 110UK

SUMMARY

USER'S INSTRUCTIONS	1
1. PRIOR TO STARTING UP	3
2. STARTING UP	4
3. SWITCHING OFF	5
4. MAINTENANCE	5
4.1. Cleaning of the stainless steel surfaces	5
4.2. Cleaning the electric plates	5
5. IN CASE OF BREAKDOWN	6

INTRODUCTION

- A) Our equipment is for professional use only and must be used by qualified staff.
- B) The equipment must be installed in compliance with local codes and bylaws. It must be installed in a kitchen equipped with an adequately sized mechanical extraction system.
- C) Appliances may be installed side by side or against walls of non combustible material. Distance to combustible material shall be no less than 10 cm.
- D) It is imperative to call for a qualified engineer for all new installations or modifications of existing equipment.
- E) WARRANTY: *The warranty is mentioned in our conditions of sale. Only a qualified engineer certifies the validity of the warranty. This warranty does not cover damage due to faulty installation, misuse or inadequate maintenance.*

1. PRIOR TO STARTING UP

- A) Prior to starting up, it is advisable to clean the electric plates in order to remove the protective oil layer necessary for storage.
- B) To do so, switch on the electric plates by setting the corresponding thermostats to the minimum position;
- C) Heat during 10 minutes about, then set the thermostat to the maxi position for 10 minutes again in order to burn oil that covers the cooking plates.
- D) Turn off the plates;
- E) Brush the cooking plate to remove all remaining particles from the surface.



It is important to turn off before each cleaning.
Warning! The plates may be very hot.
Do not switch on the plates if pans are not present.

2. STARTING UP

The appliance is switched on: The white indicator is alight.

Turn control knob of the selected electric plate to the desired heating position; the red indicator is alight (it means that the appliance is switched on).

Cooking temperatures will be reached after 10 minutes about of heating process.

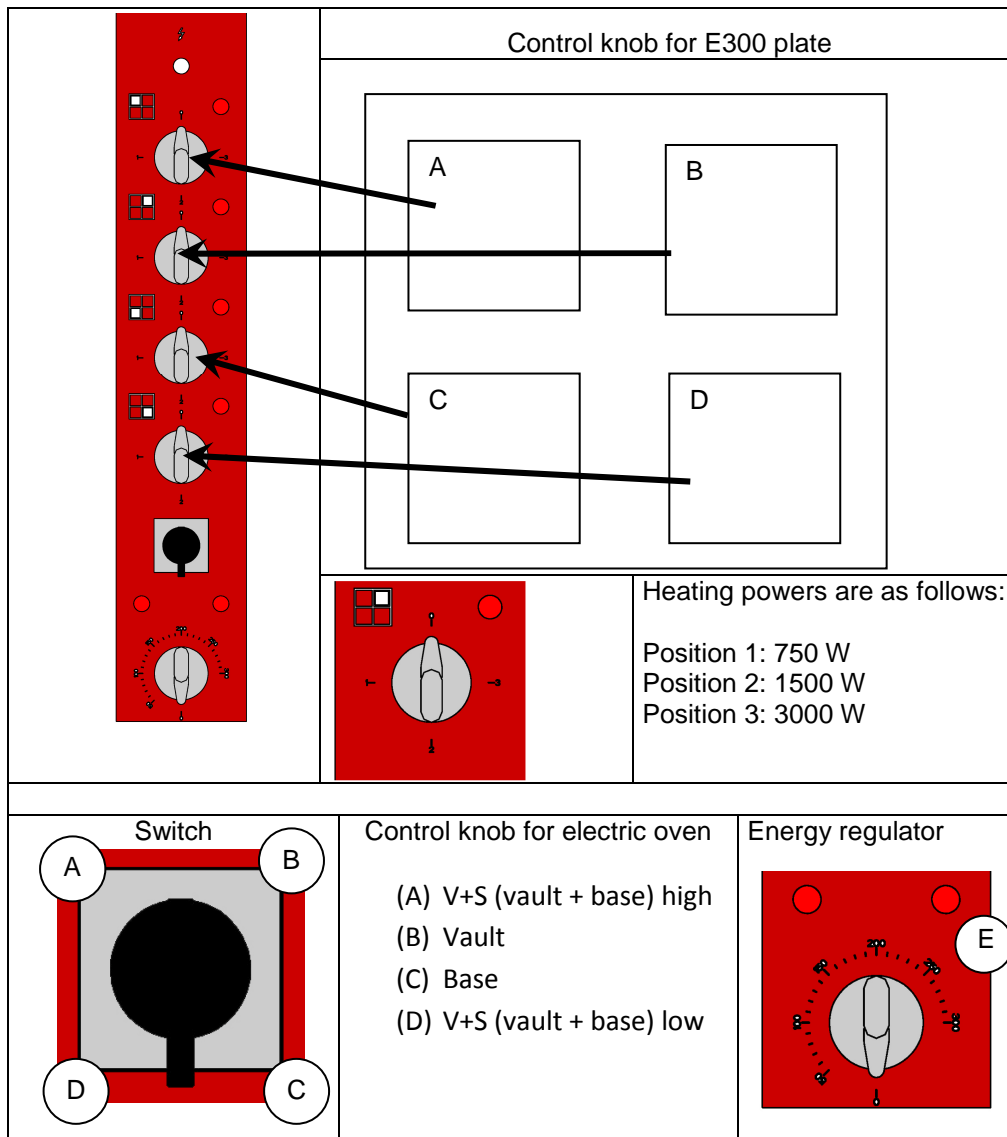

PRACTICAL ADVICE:

These electric plates are suitable for cooking and simmering various foods.

The electric plates have a power of 3000 W if you set control knob to position 3; in case the heating process is done without pan on the plates, then an overheating safety cut out device will limit temperature.

The more quick is the heating, the more quick are reach the working temperatures; we advise you to first turn control knob to position 1, and then to position 3 when serving (this will make your electric plates last longer). Running over (of liquids) may be collected in a drip tray.

WARNING:

The drip tray may be very hot; handle with care!

The top and the sides of the appliance can be very hot after prolonged and intensive use.

3. SWITCHING OFF

Bring the control knob to the "0" position.

Empty the drip tray after each use of the appliance if running over has occurred; otherwise the insulation of the cupboard may be damaged.

At the end of the day, switch off electricity at the mains.

4. MAINTENANCE

4.1. Cleaning of the stainless steel surfaces

Wash with a sponge in soapy water (or any other neutral cleaning product).

Do not use bleach or any other acidic product – even well diluted.

For the tops, use a nylon scouring pad if necessary. Always go with the grain.

After each cleaning, rub with a greased cloth or kitchen paper.

Finger marks can be removed with a cloth dabbed with alcohol.

4.2. Cleaning the electric plates

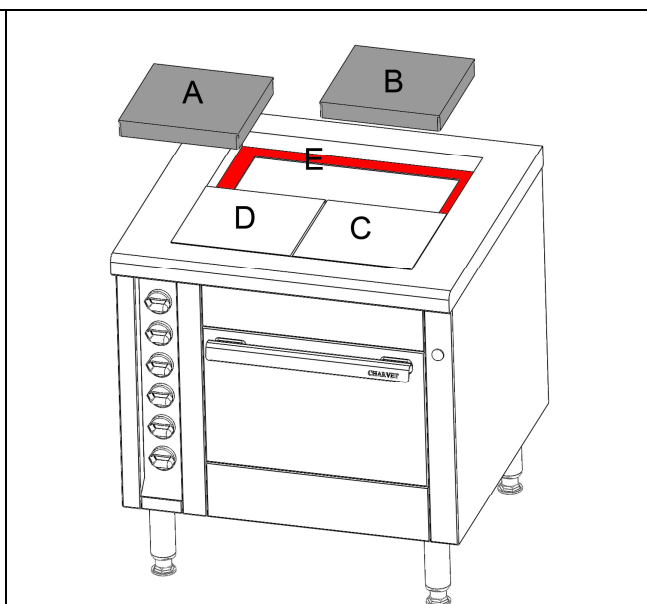
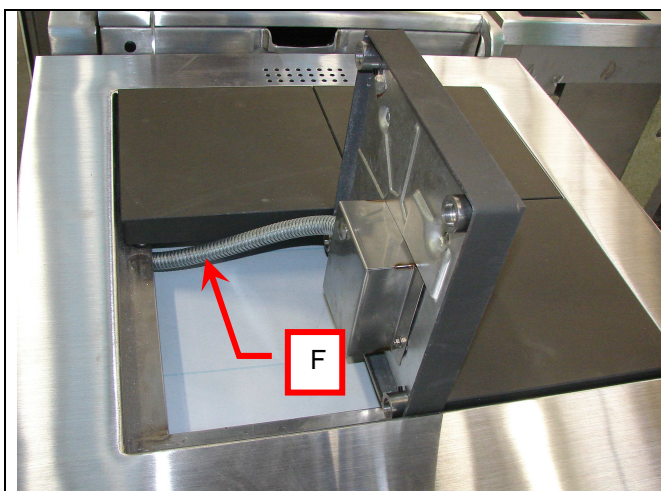

- Turn off the plates. Wait until the apparatus has cooled down before doing anything on it;
- Remove the plates in the order indicated in the illustration (A, B, C, D);
- Brush the bottom support (E) with a metal scouring pad (this operation must be done regularly);
- Replace the electric plates into their emplacement, taking care not to twist the protective sheathing (F) of the power leads (be careful with your fingers!);
- Grease the cooking plates with cooking oil if you do not use your appliance for a long time.

This appliance must not be cleaned with mechanical water jets or be subject to a deluge of water under pressure.

Check that the appliance is well disconnected at the mains.

For best results, have your equipment serviced and cleaned on a regular basis by a qualified installer.

WARNING: *Factory-sealed components must be serviced by neither installer nor user. Only a qualified electrician should replace the parts.*

5. IN CASE OF BREAKDOWN

<u>Breakdown</u>	<u>Probable causes</u>	
Unsatisfactory heating	Indicator ON but electric plate not heating.	The indicator is unlit
	Heating elements are cut.	. The electric plate is still heating up, the indicator bulb may have blown. . The electric plate do not heat up; faulty switch.

Call for your installer to replace the faulty electric components in preparation for a next use.



The manufacturer and the installer cannot be held responsible if the user neglects to ask for assistance in case of breakdown.

TRANSFER below information written on the data plate of your apparatus.

CHARVET S.A.
38850 CHARAVINES

Réf.

Code: Type:

N°FC:

N°OF: Rep.

Cat.				
Gaz				
P (mbar)				
Σ Q _n (kW)				
Σ V _n (m ³ /h)				
Σ M _n (kg/h)				

U V Hz Ip

P kW

MADE IN FRANCE

This will help you with maintenance problems and spare parts.