

“Gas-powered” direct-heating boiling pans

Description	PRO 800	PRO 900
G1MF60CD	V01637	V02517
G1MF100CD	V01638	V01528
G1MF150CD	V01639	-
G1MF200CD	V01640	V01500

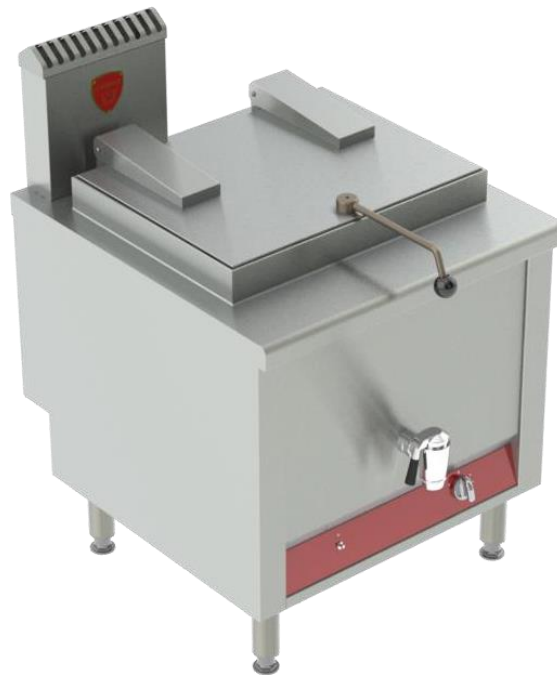

Installation manual

“Gas-powered” direct-heating boiling pans

‘Compliance with French Decree No. 2005-829 of 20 July 2005.’ **Exclusively for France**

A - In accordance with Article 18 of Decree No. 2005-829 of 20 July 2005 on the disposal of waste electrical and electronic equipment, the Paul CHARVET company takes responsibility for the financing and organisation of the disposal of its waste. As such, the Paul CHARVET company resumes full ownership of the electrical and electronic equipment at the end of its life.

The equipment should be palletised and ready for loading in a place that is accessible by the carrier. Except in exceptional circumstances, the equipment shall in no case have been dismantled, even partially, otherwise CHARVET reserves the right to re-invoice the costs of processing and taking responsibility for the equipment.

B- How WEEE is disposed of:

The terms and conditions of disposal are covered by the SYNEG/RECYSTEM-PRO agreement, which states that: “In order to fulfil their obligations, the producers of electrical and electronic equipment for large kitchens grouped within the SYNEG, have implemented arrangements for the collection and processing/recycling of WEEE in accordance with the provisions of the decree.

Materials or substances harmful to the environment (such as refrigerants or foams) are extracted or separated. The metal fractions (stainless steel, zinc, copper, etc.) are crushed and transported to refiners for reuse. Therefore, when you need to have electrical equipment collected by a SYNEG professional kitchen equipment manufacturer, you must contact RECYSTEM-PRO, the operator chosen for the management of WEEE

↳ at this telephone number: 01 45 01 71 43.

↳ or at the following e-mail address: synegdeee@recystempro.com

You will then be sent a collection request sheet which will contain the following elements:

- name of the producer of the equipment
- type of equipment
- estimated weight
- place of collection
- name and contact details of the installer
- invoicing address

After verification with the producer and obtaining its agreement, RECYSTEM-PRO will proceed with the collection.”

“This device complies with the 2009/142 (Declaration of conformity to type) directive”



“Gas-powered” direct-heating boiling pans

1. INSTALLATION

1.1. General

The equipment must be installed according to best practice and in accordance with the instructions in this manual and the regulations in force in the country of installation.

The user manual must be handed over to the user after installation.

1.2. Handling - Positioning

It is imperative to leave the appliance on its wooden pallet during the handling process until the final installation. Unpack and check the appliance for damage upon receipt.

In case of damage, detail it immediately on the delivery note; notify the carrier by registered mail with acknowledgement of receipt within 48 hours.

1.3. Installation

SEE data sheets

This equipment must be installed under an extractor hood in accordance with the regulations in force (RSDT – RSCI – E.R.P).

If the appliance is to be installed against a wall or partition, near a piece of furniture or decorative borders, it is recommended that these are made of fireproof material.

If this is not the case, they must be protected by an approved fireproof, insulating material.

Special attention should be paid to the fire prevention regulations of the establishment concerned (SEE fire prevention regulations).

In case of doubt regarding materials, allow a 10 cm space around your appliance.

- Remove all protective plastic wrapping from the outer panels.

Attach the discharge flue (see §1.4.) to the top of the appliance and make sure that nothing is clogging the flue (inside/outside).

- **Fixed appliance:**
 - Fit the legs (these are delivered in a box placed inside the pan of the appliance).
 - Level the appliance by adjusting the height of the legs to obtain a horizontal working surface height of 900 mm.
- **Mobile appliance:**
 - Put the appliance in its working location in the cooking area near the gas supply necessary for its operation.

IMPORTANT: The brakes on the castors must be in locked position when the appliance is in position for connection and when the cooking function is in operation.

1.4. Mounting the flue

Insert one of the flue's retaining tabs into the appliance. Push in the second tab using a tool. Tighten the screws in the flue cap.

1.5. Gas connection

The installation must take place in a sufficiently ventilated room with mechanical extraction, according to best practice, the regulations and standards in force in the country of installation and the instructions contained in this manual.

This appliance is an A-type and must not be connected to a flue gas pipe.

The new air flow required to supply combustion is $PN \times 2 \text{ m}^3/\text{h}/\text{kW}$ of heat output:

“Gas-powered” direct-heating boiling pans

SEE adjustment tables in § 2

CAUTION:

Use authorised materials and assembly and welding equipment (EN 45 204).

- **Fixed appliance:**

Connect the appliance on its standby manifold ($\frac{1}{2}$ " male pipe threaded for gas) to the fixed gas supply pipe, inserting a block valve so that the appliance can be isolated from the rest of the installation.

- **Mobile appliance:**

Connect the appliance on its standby manifold ($\frac{1}{2}$ " male pipe threaded for gas) to the fixed gas supply pipe using an authorised gas hose fitted with a quick coupler with 2-way automatic shut-off, inserting a block valve so that the appliance can be isolated from the rest of the installation.

- **Before connecting, ensure that:**

The gas supply pipeline is correctly sized so as to minimise pressure drops, the diameter is determined according to the power of the appliance, the gas pressure, the path travelled (length and number of elbows).

Check that the appliance is set for the type of gas delivered to the installation (type/pressure), this information is on the label on the front of the equipment.

1.6. Electrical connection

Electric spark ignition appliances with 'sequential burners' option.

The equipment must be installed according to best practice, the instructions in this manual and the regulations and standards in force in the country of installation.

CAUTION:

Use standard cable (245 IEC 57 or 245 IEC 66) or other types of cable with the same characteristics.

- **Fixed appliance:**

The appliance is permanently connected to a mains supply, this mains must be suitably protected against leakage currents.

- **Mobile appliance:**

The appliance is connected by a cable with a socket plug suitable for the power. This socket must be accessible at all times.

- **Before connection:**

- Check that the electrical voltage of the supply is compatible with the voltage and wattage of the appliance (SEE data plate).
- Ensure that the user's fixed installation has an all-pole circuit breaker with point gap of 3.5mm in compliance with standard EN 60335-1 of May 2003.

The appliance is factory wired in SINGLE PHASE 230 V + T (1 N ~ 230 V + PE).

2. ADAPTING THE APPLIANCE TO DIFFERENT TYPES OF GAS

If delivered for a gas other than that of the supply to be connected.

2.1. Changing the injectors

Refer to the tables below according to the burner:

- To select the diameter to suit the gas in the connected supply.
- To display the air adjustment dimension 'd' to be performed on the burner's air sleeve.

In case of gas change at the installation:

After changing injectors, check the tightness of the gas circuit at the injector/injector holder connection point.

“Gas-powered” direct-heating boiling pans

2.1.1. 60 l boiling pan: Burner (multi-manifold burner, Venturi Ø 25)

Setting	Gas type under nominal pressure	Marker engraved on the injector	Air adjustment d (mm) ²	Nominal heat output kW ¹
1	G 20: Pn = 20 mbar	250	0	11.60
2	G 25: Pn = 20 mbar			
3	G 25: Pn = 25 mbar	250	0	
4	G 30: Pn = 29 mbar			
5	G 30: Pn = 50 mbar			
6	G 31: Pn = 37 mbar	170	0	11.60
7	G 31: Pn = 50 mbar			

- ¹: Measured power on lower calorific value of gas (HI)
- ²: Primary measured air setting as shown in Figure 1

2.1.2. 100 l boiling pan: Burner (multi-manifold burner, Venturi Ø 25)

Setting	Gas type under nominal pressure	Marker engraved on the injector	Air setting d (mm) ²	Nominal heat output kW ¹
1	G 20: Pn = 20 mbar	330	7	19.80
2	G 25: Pn = 20 mbar			
3	G 25: Pn = 25 mbar	330	7	
4	G 30: Pn = 29 mbar			
5	G 30: Pn = 50 mbar			
6	G 31: Pn = 37 mbar	230	8	19.80
7	G 31: Pn = 50 mbar			

- ¹: Measured power on lower calorific value of gas (HI)
- ²: Primary measured air setting as shown in Figure 1

2.1.3. 150 l boiling pan: Burner (multi-manifold burner, Venturi Ø 25)

Setting	Gas type under nominal pressure	Marker engraved on the injector	Air adjustment d (mm) ²	Nominal heat output kW ¹
1	G20: Pn = 20 mbar	380	3	25.60
2	G 25: Pn = 20 mbar			
3	G 25: Pn = 25 mbar	380	3	
4	G 30: Pn = 29 mbar			
5	G 30: Pn = 50 mbar			
6	G 31: Pn = 37 mbar	250	4	25.60
7	G 31: Pn = 50 mbar			

- ¹: Measured power on lower calorific value of gas (HI)
- ²: Primary measured air adjustment as shown in Figure 1

2.1.4. 200 l boiling pan: Burner (multi-manifold burner, Venturi Ø 25)

Setting	Gas type under nominal pressure	Marker engraved on the injector	Air adjustment d (mm) ²	Nominal heat output kW ¹
1	G20: Pn = 20 mbar	420	5	31.40
2	G 25: Pn = 20 mbar			
3	G 25: Pn = 25 mbar	420	5	
4	G 30: Pn = 29 mbar			
5	G 30: Pn = 50 mbar			
6	G 31: Pn = 37 mbar	280	6	31.40
7	G 31: Pn = 50 mbar			

- *1 Measured power on lower calorific value of gas (HI)
- *2 Primary measured air adjustment as shown in Figure 1



“Gas-powered” direct-heating boiling pans

2.1.5. Pilot light

BOILING PAN			
Setting	Gas type under nominal pressure	Marker engraved on the injector	Air adjustment
1	G20: Pn = 20 mbar	40	50%
2	G 25: Pn = 20 mbar		
3	G 25: Pn = 25 mbar		
4	G 30: Pn = 29 mbar	20	Max.
5	G 30: Pn = 50 mbar		
6	G 31: Pn = 37 mbar		
7	G 31: Pn = 50 mbar		
8	G20: Pn = 20 mbar	40	50%

2.2. Air adjustments

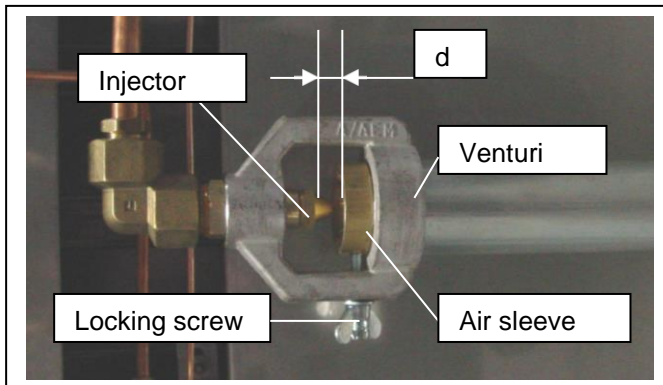

Figure 1

Remove the front panel,

The air ring and the injector are now accessible.

Release the air sleeve locking screw and move the air sleeve back to access the injector

Change the injector(s)
(17 mm ring spanner)

Adjust the distance 'd', re-lock the wing screw, seal it.

2.3. Electrical checks and inspections

(Ignition & sequential burner of appliances connected to the electrical mains)

Before switching on the appliance, make sure:

- that the supply voltage is correct,
- that the cable is fixed correctly,
- that the appliance's connections are tight,
- that the appliance is correctly earthed,
- that the cable diameter is correct,
- that the electrical equipment is insulated,
- that protective devices are the correct rating.

2.3.1. Adjustments

No adjustment is normally necessary on the electrical part.

2.3.2. Starting up:

(Refer to the user section on starting up the appliance)



**Never put into operation when the pan is empty.
Remove any objects from the pan.
All the above operations are carried out while the appliance is cool.**

“Gas-powered” direct-heating boiling pans

- **Connections: G1MF..dimensions:**

GAS:

Threaded pipe M 1/2"

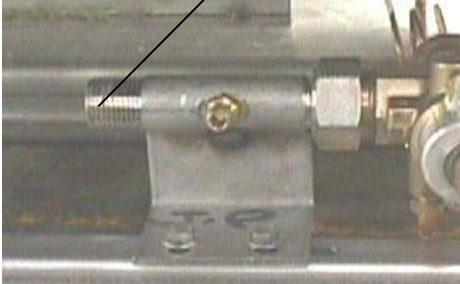

Remove the control knob. (fixed with M 4 mm socket set screw). Remove the front panel (lower part fixed with screw). Pull the bottom towards you, lower it to remove the upper mountings. Connect to M 1/2" tube on the standby manifold.

ELECTRICITY:

Cable



The appliance is delivered with a flexible high temperature cable. Fit a standard 230 V + T SINGLE PHASE plug. Plug the appliance into a standard socket.

Ensure that the socket is properly protected on the electrical panel.

- Before remounting, check that the electrical insulation of the appliance is in good order (condition of the cable).

OPTION: HOT WATER/COLD WATER

HW/CW mixed water tap on right or left side.

HW/CW supply Ø 15/21 with shut-off valves required.



**The appliance must be earthed.
It is dangerous to put the appliance into service without connecting it to earth.**

Our liability cannot be incurred in the event of accidents resulting from non-existent or incorrect earthing.

WIRING DIAGRAMS:

Appliance	Voltage	Wiring diagram No.
Electric ignition	SINGLE PHASE ~ 230 V + PE	SE0001/00

3. INTERVENTIONS



Any intervention or repair on an appliance must be undertaken by a qualified installer.

The apparatus will be isolated from the gas supply by closing the gas valve.

The apparatus will be isolated from the electricity supply by disconnecting the plug.

“Gas-powered” direct-heating boiling pans

When the appliance is ready, train users on the proper use of the appliance (SEE the user manual). Formally hand the documentation to the kitchen manager.

Each appliance has a data plate.

Record the information on the data plate in the part of the manual reserved for that purpose.

Data plate

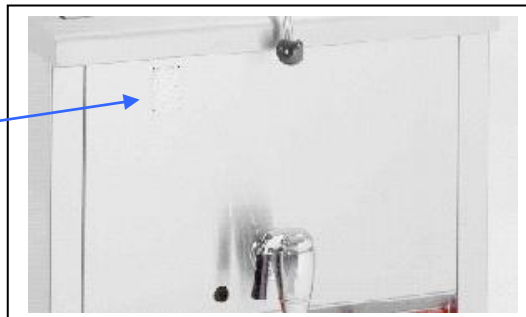

This will make it easier for you to communicate with your customer for better service delivery.

WARRANTY:

The warranty is part of the sale contract.

This warranty does not cover any damages due to faulty installation, misuse or inadequate maintenance.

“Gas-powered” direct-heating boiling pans

4. LIST OF BASIC SPARE PARTS

Code	Description	Code	Description	Code	Description
F04542-60CD F04543-100CD F04544-150CD F04544-200CD		07550A GP 07551A GN		06988A GP 06430 GN	
Boiling pan burner		Pilot light		Pilot light injector	
GAZ NAT 00209A-60CD 00217A-100CD 00222A-150CD 00226A-200CD		00312A		00290A	
Injector Natural gas		Gas tap		Thermocouple	
ELE0018		02161A		05315A	
Ignition push button new model		Electric igniter		Ignition spark plug	
03013A		F09386		04118A	
High voltage cable		Full standard hinge (indicate stop height)		Lid hinge spring	
01996A		505691		03919A Ø50-60 03917A Ø40-49 03915A Ø33-42	
Control thermostat		Gas control knob		Drain tap	
		05690A		04035A	
		Thermocouple switch		Ball of lid handle	

“Gas-powered” direct-heating boiling pans

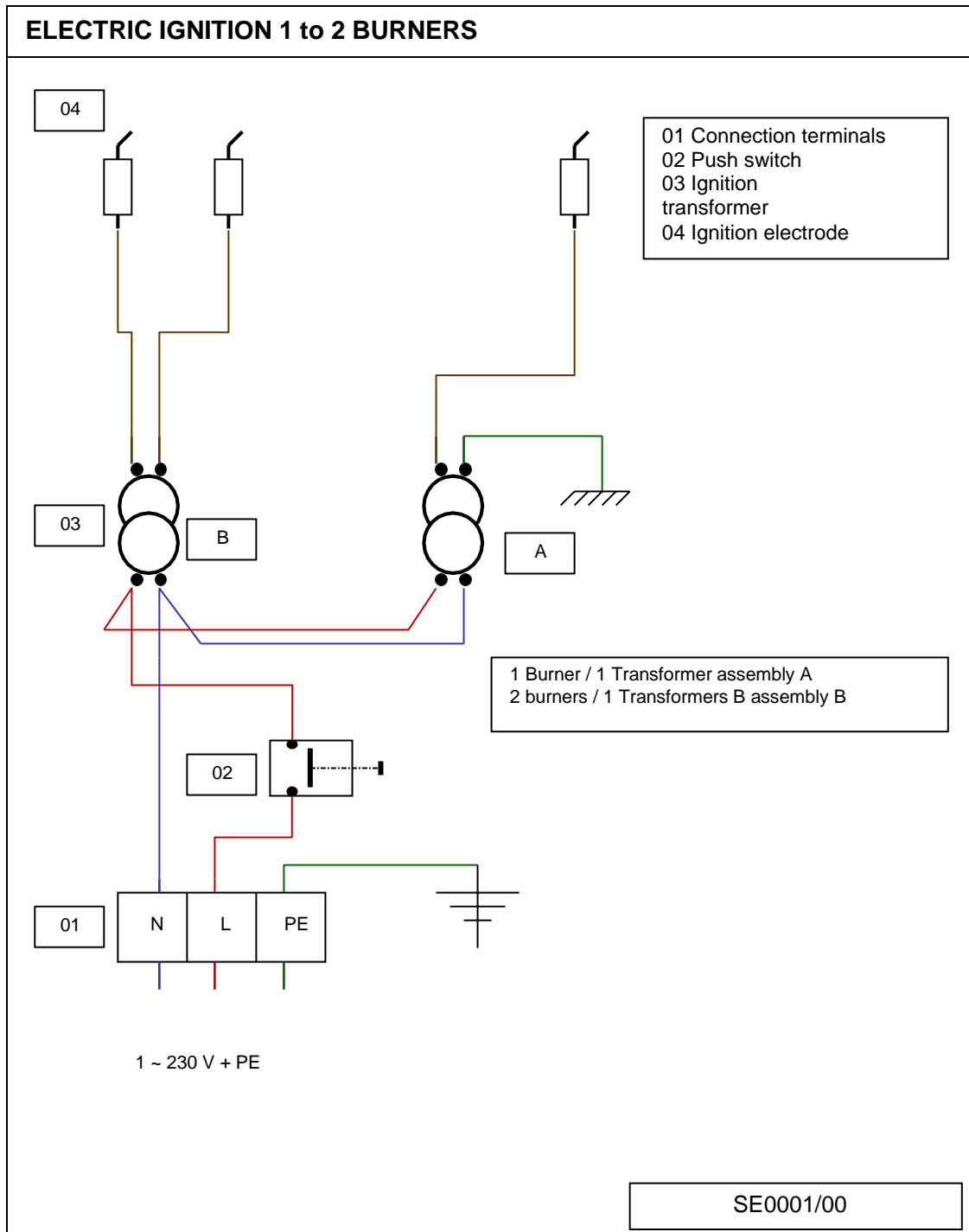

“Gas-powered” direct-heating boiling pans

Description	PRO 800	PRO 900
G1MF60CD	V01637	V02517
G1MF100CD	V01638	V01528
G1MF150CD	V01639	-
G1MF200CD	V01640	V01500



User manual

“Gas-powered” direct-heating boiling pans

‘Compliance with French Decree No. 2005-829 of 20 July 2005.’

Exclusively for France

A - In accordance with Article 18 of Decree No. 2005-829 of 20 July 2005 on the disposal of waste electrical and electronic equipment, the Paul CHARVET company takes responsibility for the financing and organisation of the disposal of its waste. As such, the Paul CHARVET company resumes full ownership of the electrical and electronic equipment at the end of its life.

The equipment should be palletised and ready for loading in a place that is accessible by the carrier. Except in exceptional circumstances, the equipment shall in no case have been dismantled, even partially, otherwise CHARVET reserves the right to re-invoice the costs of processing and taking responsibility for the equipment.

B- How WEEE is disposed of:

The terms and conditions of disposal are covered by the SYNEG/RECYSTEM-PRO agreement, which states that: “In order to fulfil their obligations, the producers of electrical and electronic equipment for large kitchens grouped within the SYNEG, have implemented arrangements for the collection and processing/recycling of WEEE in accordance with the provisions of the decree.

Materials or substances harmful to the environment (such as refrigerants or foams) are extracted or separated. The metal fractions (stainless steel, zinc, copper, etc.) are crushed and transported to refiners for reuse. Therefore, when you need to have electrical equipment collected by a SYNEG professional kitchen equipment manufacturer, you must contact RECYSTEM-PRO, the operator chosen for the management of WEEE

- ➔ at this telephone number: 01 45 01 71 43.
- ➔ or at the following e-mail address: synegdeee@recystempro.com

You will then be sent a collection request sheet which will contain the following elements:

- name of the producer of the equipment
- type of equipment
- estimated weight
- place of collection
- name and contact details of the installer
- invoicing address

After verification with the producer and obtaining its agreement, RECYSTEM-PRO will proceed with the collection.”

"This device complies with the 2009/142 (Declaration of conformity to type) directive"



“Gas-powered” direct-heating boiling pans

1. INTRODUCTION

- A) Our appliances are intended for professional use and should be used by qualified personnel.
- B) They must be installed in accordance with the regulations and standards in force in the country of installation, in a sufficiently ventilated room with an extractor hood.
- C) The appliance may be placed next to others or against fireproof walls, but must not, under any circumstances, be located within 10 cm of any combustible element.
- D) Any modifications to existing equipment or any new installations must be carried out by a qualified installer.
- E) This manual is a contractual document that must be handed over to the user after installation.
- F) **WARRANTY:** *The warranty is part of the sale contract. For any work to be carried out under the warranty, please contact an authorised dealer. This warranty does not cover any damages due to faulty installation, misuse or inadequate maintenance.*

Dimensions:

length 450 mm (60 l), 850 mm (100 / 150 / 200 l).
depth 800 mm.
height 900 mm

Construction:

One-piece carrier frame in 18-10 stainless steel, thickness 1 to 3 mm, assembled by electrical welding.
Pan top in 18-10 stainless steel (AISI 304 L), thickness 2 mm with 55 mm front lip (top angle radius 18 mm) and crossbanding.
2 mm thick stainless steel boiling pan with rounded corners, 316L sloping steel pan bottom, stainless steel ferrule.
 . 60 l pan dimensions: 305 mm x 500 mm x depth 400 mm
 . 100 l pan CD: 540 mm x 500 mm x depth 400 mm
 . 150 l pan dimensions: 730 mm x 500 mm x depth 400 mm
 . 200 l pan dimensions: 710 mm x 547 mm x depth 530 mm.
Removable strainer in 18-10 stainless steel.
Vertical outer panels (visible sides) made of 1 mm thick 18-10 stainless steel, no visible screws. Control panel made of enamelled sheet metal, screen printed markings.
10/10 mm thick stainless steel lid on spring-balanced hinges.
Recessed self-adjusting gas fittings, bead-blasted aluminium control levers. Multi-manifold burner, permanent pilot light for electric ignition, safety by thermocouple mounted on the pilot light.
200 mm high legs made of 60.3 mm diameter stainless steel tube with levelling flat bottoms (+ 10 / - 20 mm).

Options:

Full pan in stainless steel (AISI 316 L) for cooking acidic and/or salty food. Burner equipped with sequential regulation.
Pan filled with water via HW/CW gooseneck mixed water tap with 180° or 360° movement.
Balanced lid in all positions.

2. STARTING UP FOR THE FIRST TIME

- a) Prior to starting up for the first time, it is advisable to clean the appliance in order to eliminate all dust or impurities that have accumulated during storage.

To do this, put warm water and detergent in the pan (1 to 2 cm).

- b) Pass a sponge over the walls and the bottom of the pan to remove any remaining particles.
- c) Drain the pan by opening the drain tap on the front, rinse thoroughly.



“Gas-powered” direct-heating boiling pans

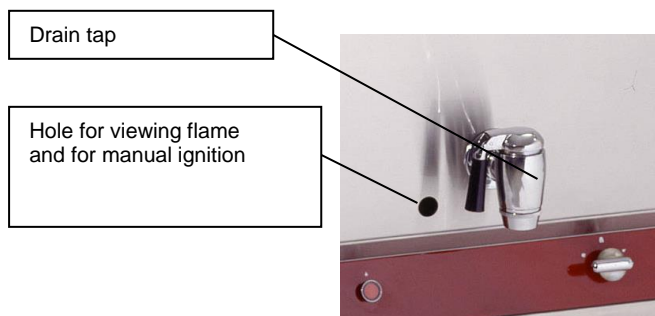

- d) Remove all protective plastic wrapping from the stainless steel parts.
- e) Make sure that the control component is functional, then open the gas block valve.



DO NOT HEAT THE PAN WHEN EMPTY
Before any ignition, including the pilot light, put water in the pan to cover the bottom.

3. STARTING UP

General: The burner of this appliance is equipped with a thermocouple safety system and a permanent pilot light.

3.1. Burner

Push and turn the burner control knob: Fig. 2

anti-clockwise until it is pointing to the spark. Press the knob down fully and at the same time press the ignition push button.

If the electric ignition is not working, manual ignition is still possible by presenting a flame through the flame check hole.

Keep the control knob pressed down for a few seconds (approximately 5 to 15 seconds) before releasing it. The pilot light should remain lit. If this does not work, repeat the operation.

With the pilot light on, turn the control knob anti-clockwise until it is at the 'full flame' position, the burner operates at its nominal power.

Turning the knob to the next position (pointing to the small flame) gives the lower output.

If the electrical ignition does not work, an ignition torch can be passed through the hole in the front panel for ignition.



Figure 2

“Gas-powered” direct-heating boiling pans

3.2. PRACTICAL ADVICE:

Direct heating boiling pans allow all varieties of wet cooking in a large volume of water (vegetables, rice, pasta, etc.). For cooking in a thick sauce, water-jacketed boiling pans are preferable (casseroles, milk-based preparations, etc.). For sautés, bratt pans are preferable. The lid will be opened or closed depending on the type of cooking.

When salting foods or cooking water in the pan with coarse salt, make sure it is diluted so that grains do not collect on the bottom.

Caution:

When opening the lid during ‘wet’ cooking, be careful of steam escaping as you pass your arm over the pan because there is a risk of burning.

When emptying:

- Keep away from the area where cooked products are to be drained, there is a risk of burning due to splashes.

The walls of the pan, the lid and the body of the drain tap may be very hot after intense or prolonged use, only hold the drain tap and the lid by the handles.

4. SWITCHING OFF

Return the gas tap control knob to the OFF position. Drain and clean the pan after each use of the appliance (avoid allowing leftover food or washing fluids to dry on it). At the end of the day, shut off the gas valve and the electric power supply (or disconnect the plug).

5. MAINTENANCE

5.1. Cleaning the stainless steel surfaces

Wash with a sponge in soapy water (or any other neutral cleaning product).

Do not use bleach or any acid or chlorine product even if heavily diluted.

If necessary, use a scouring sponge for the tops, taking care to always rub **in the direction of polishing**. After each cleaning, rub with an oily rag.

Finger marks can be removed with a cloth soaked in alcohol.

- a) Switch off the heating.
- b) Wait for the appliance to cool down before any intervention.

5.2. Cleaning the pan

This cleaning can be carried out by soaking, washing with water and a dishwasher cleaning product. Thoroughly rinse the bottom of the pan with plenty of water to remove any remaining salt, thereby avoiding the risk of pitting the stainless steel.

Do not use bleach or any acid or chlorine product even if heavily diluted.

After cooking salty or acidic food, rinse the pan with clean water.

5.3. Cleaning the burner

If burner cleaning becomes necessary, contact your installer.

This appliance must not be cleaned by water jets under pressure and large amounts of water must not be sprayed on the burners (risk of clogging of the gas outlet holes).

Electric ignition: check that the appliance is disconnected from the mains.

“Gas-powered” direct-heating boiling pans

6. PROBLEM

NO HEAT Probable causes: Clogging of burner outlets, of injectors... Gas supply pressure not correct.

Incorrectly calibrated injector.

FAULTY IGNITION

Clogging of pilot light holes, clogging of the thermocouple (sensitive part),

Difficult to arm thermocouple, insufficient pilot output, positioning, pushing down on the control knob. Faulty electric ignition.

Contact the installer to replace any faulty electric control components before further use.





Only a qualified electrician may replace the ignition transformers.

The manufacturer and the installer CANNOT BE HELD LIABLE if the user does not make a request for repairs due to these malfunctions.

“Gas-powered” direct-heating boiling pans

Please RECORD the information on the DATA PLATE of your appliance below.

This information will facilitate communication with your installer for maintenance and the supply of spare parts.

 CHARVET S.A. 38850 CHARAVINES	
Réf.	<input type="text"/>
Code:	<input type="text"/> Type: <input type="text"/>
N°FC:	<input type="text"/>
N°OF:	<input type="text"/> Rep. <input type="text"/>
Cat.	<input type="text"/>
Gaz	<input type="text"/>
P (mbar)	<input type="text"/>
ΣQ_n (kW)	<input type="text"/>
ΣV_n (m ³ /h)	<input type="text"/>
ΣM_n (kg/h)	<input type="text"/>
U <input type="text"/> V <input type="text"/> Hz Ip <input type="text"/>	
P <input type="text"/> kW <input type="text"/>	
 <input type="text"/>	
MADE IN FRANCE	

