

Electric Tilting Bratt pan

**Series: AEROGAM
SERIES**

BRATT PANS 50 & 80 dm²

- ✓ **V01318 . 1755: AEROGAM1000 E1SBM50I, E1SBM50I/D**
- ✓ **V01319 : AEROGAM1500 E1SBM80I**

INSTALLATION MANUAL



Electric Tilting Bratt pan

1. INSTALLATION

1.1. General points

Installation must be undertaken in compliance with the following instructions and with local codes and by-laws.

The user's manual must be given to the user after installation.

1.2. Handling - Installation

It is imperative to leave the appliance on its wooden pallet during the handling process until the final installation.

Unpack and check the appliance for damage upon receipt.

In case of damage, mark delivery note immediately and accordingly (within 48 hours); notify the carrier by registered mail with acknowledgement of receipt. Notify your installer.

1.3. Installation

SEE technical sheets.

The appliance must be installed under a suitable aspiration hood.

If the apparatus is to be installed against a wall or partition, near a piece of furniture or decorative borders, it is recommended that these are made of fireproof material.

If this is not the case, they must be protected by an approved fireproof, insulating material.

Special attention must be paid to the local fire prevention regulations of the organization concerned (see [Public Access Premises]).

If in doubt of the fireproof construction of adjacent walls, the distance to combustible material should be no less than 10 cm.

- ☞ Remove all plastic protection.
- ☞ Install the feet (they are delivered in a box kept inside the appliance).
- ☞ Adjust height to level the unit to a horizontal working plan of 900 mm.

1.4. Power connection

Installation must be undertaken in compliance with the following instructions and with local codes and by-laws. Ensure a suitable and sufficient risk assessment is in place.

CAUTION:

Use a standardized cable (245 IEC 57 or 245 IEC 66) or other approved cable with the same characteristics.

As the appliance is constantly connected to a fixed electric source, this source will have to be fitted with a suitable leakage current protective device.

The appliance is connected to a cable fitted with an electrical plug; the socket should be accessible at all times.

☞ Before connection:

- Check that the supply voltage is compatible with the voltage of the appliance (see data plate).
- Check that the electric network is equipped with all-pole circuit breakers with a cross section of 3 mm.

The appliance is wired at the factory according to requirements notified at the time of order.

CHANGE OF VOLTAGE:

- The heating element coupling is specified for the voltage.
- Please consult the manufacturer.



Electric Tilting Bratt pan

1.5. Powering on

1.5.1. CHECKS

Before connecting the appliance, check that:

- The supply voltage is compatible with the voltage of the apparatus.
- The cable is fixed properly.
- The connections are tight enough.
- The apparatus is earthed properly.
- The section of the cable is suitable for the power.
- The electrical equipment is well insulated.
- The electric current requirements are compatible with the phases.

1.5.2. Adjustments

Normally, no adjustment is necessary.

2. STARTING UP

Please see the user's manual, section "Starting up"



**Never start up whilst the tank is empty for a long time (danger of causing blue discolouration to the tank's base).
The tank must be free of all objects.**

3. Connections

3.1. Electrical connections

- Open the connection box, which is located under the bratt pan (fixed with four screws).
- Remove the upper plug, and fix a cable-stop gland suited to the cross-section of the cable.
- Enter the connection box via the cable gland.
- Connect the power cable to the terminals, following the information written on the box (see table below).

☞ Before reassembling the parts, check that the electrical equipment is properly insulated (condition of the cable).



**The appliance must be earth wired.
It is dangerous to connect the appliance unless it is earthed.**

We cannot be held responsible for accidents due to non existent or incorrect earth wiring.

3.2. Wiring Table

| Appliance | Voltage | Wiring diagrams # |
|----------------------|---------------|-------------------|
| E1SBM50I, E1SBM50I/D | 3 ~ 400 V + E | SE0020 / 00 |
| E1SBM80I | 3 ~ 400 V + E | SE0040 / 00 |

The overheat thermostat is pre-set at 275° C by the factory and this level should not be altered (danger of irreversible warping of the tank's base and blue discolouration of the tank's stainless steel).



Electric Tilting Bratt pan

4. SERVICING



Any maintenance or repair on an appliance must be undertaken by a qualified technician.

The appliance must be isolated from the electrical supply for the duration of the work.

When the appliance is ready for use, ensure the users know how to use it properly.
(Please see the user's manual.)

Formerly present the person in charge of the kitchen with all documentation needed.

Each appliance has its own data plate.

Transfer all the information written on the data plate to the part of the user's instructions booklet reserved for it.

Data plate



This will make communications between you and your client easier and provide better service.

WARRANTY:

The warranty is discussed in our sale contract.

This warranty does not cover damage due to faulty installation, misuse or inadequate maintenance.

CHARVET









38850 – CHARAVINES
Tel.: (33)-4-76-06-64-22
Fax: +33 (0) 4 76 55 78 75
Email: info@charvet.fr



MANUAL AEROGAM EN ESB;
ind.: B; Created on: 14/08/2002
Updated on: 18-12-2013
Page: 4/15

Electric Tilting Bratt pan

5. BASIC SPARE PARTS LIST

| Description / Code | Photo | Description / Code | Photo |
|---|---|---|---|
| Heating element 1250 W - 230 V 09032A |  | 400 V Indicator 02142A |  |
| Contactor coil 400 V 505805 |  | 5mm x 20mm, 5 A fuse 03413A |  |
| Energy regulator 400 V 09088A |  | Overheat thermostat 350° C 01999A |  |
| Indicators Red 02131A Yellow 05075A |  | Limit detector 05091A |  |

Electric Tilting Bratt pan

BRATT PAN AEROGAM E SBM/I 80L

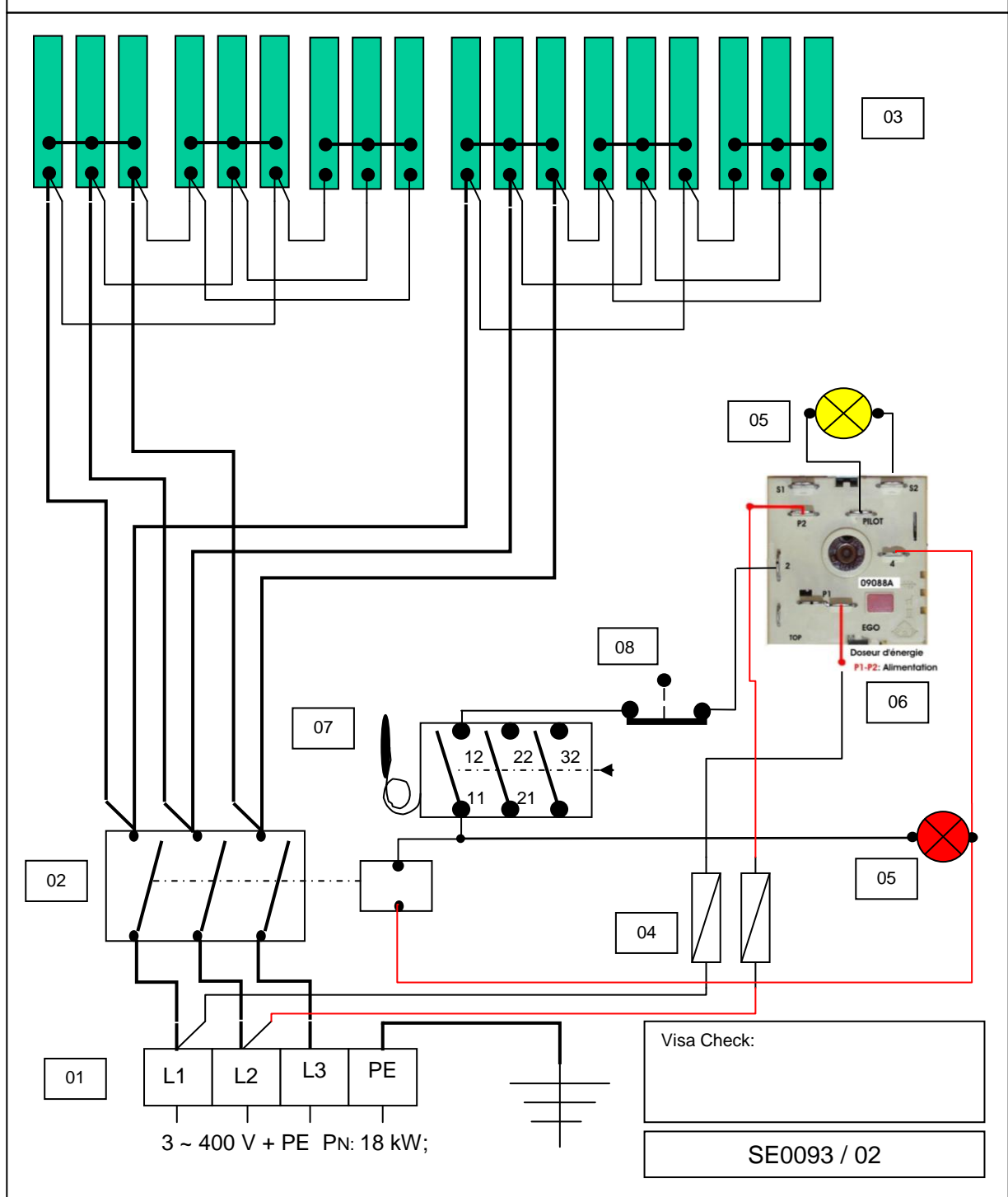

Electric Tilting Bratt pan

NOMENCLATURE: E1SBM50I, E1SBM50/80I/D (wiring diagram SE0093 / 00)

| No. | Code | Specification | Quantity |
|-----|--------|---|----------|
| 01 | 02468A | 10 mm ² terminal (brand: Viking) | 3 |
| 01 | 03575A | 10 mm ² earth terminal (brand: Viking) | 1 |
| 02 | 505805 | Contacteur | 1 |
| 03 | 09032A | Heating element 1250 W, 230 V (ESBM50) | 12 |
| 03 | 09032A | Heating element 1250 W, 230 V | 18 |
| 04 | 03413A | Fuse Ø 5 mm x 20 mm, 5 A | 2 |
| 05 | 02131A | Red indicator | 1 |
| 05 | 02142A | Bulb 400 V | 2 |
| 05 | 05075A | Yellow indicator | 1 |
| 06 | 09088A | Energy regulator 400 V | 1 |
| 07 | 01999A | Safety thermostat 50°C-350°C | 1 |
| 08 | 05091A | Limit | 1 |



Electric Tilting Bratt pan

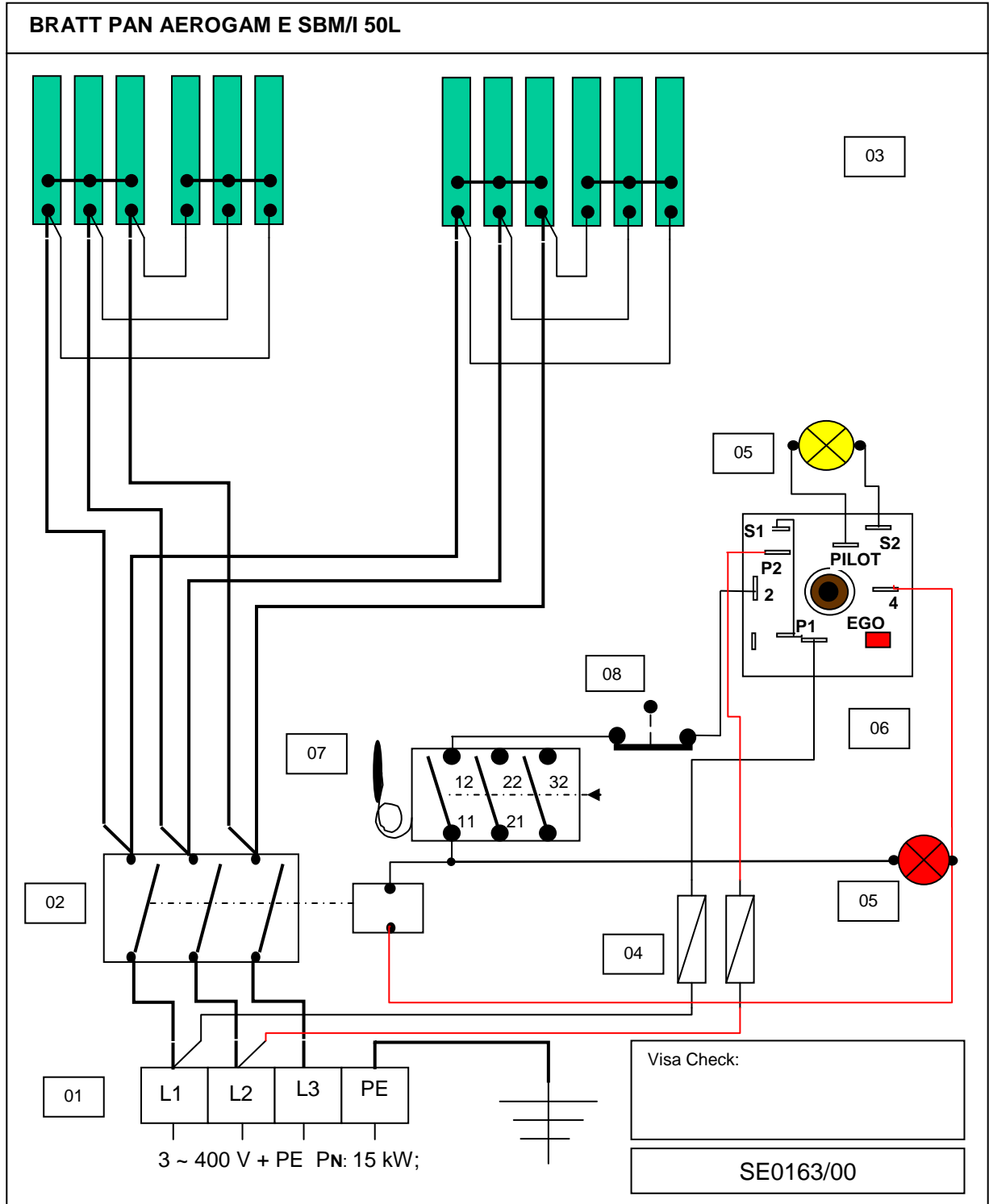

Electric Tilting Bratt pan

Nomenclature: Bratt pan ESBM/I 50 (Aerogam) (SE0163/00)

| No. | Code | Specification | Quantity |
|-----|--------|---|----------|
| 01 | 02468A | 10 mm ² terminal (brand: Viking) | 3 |
| 01 | 03575A | 10 mm ² earth terminal (brand: Viking) | 1 |
| 02 | 505805 | Contacteur | 1 |
| 03 | 09032A | Heating element 1250 W, 240 V | 12 |
| 04 | 03413A | Fuse Ø 5 mm x 20 mm, 5 A | 2 |
| 05 | 02131A | Red indicator | 1 |
| 05 | 02142A | Bulb 400 V | 2 |
| 05 | 05075A | Yellow indicator | 1 |
| 06 | 09088A | Energy regulator 400 V | 1 |
| 07 | 01999A | Safety thermostat 50°C-350°C | 1 |
| 08 | 05091A | Limit | 1 |



Electric Tilting Bratt pan

Series: AEROGAM SERIES

BRATT PANS 50 & 80 dm²

- √ **V01318: 1755: AEROGAM1000 E1SBM50I, E1SBM50I/D**
- √ **V01319: AEROGAM1500 E1SBM80I**

USER'S INSTRUCTIONS



Electric Tilting Bratt pan

1. INTRODUCTION

- A) Our equipment is for professional use only and must be used by qualified staff.
- B) The equipment must be installed in compliance with regulations and standards in force in the country of installation, in an adequately aerated room equipped with an air extraction hood.
- C) Appliances may be installed side by side or against walls of non combustible material. Distance to combustible material should be no less than 10 cm.
- D) **It is imperative to call for a qualified engineer for all new installations or modifications of existing equipment.**
- E) **This instruction manual is contractual and must be presented to the user after installation.**
- F) ***WARRANTY: The warranty is discussed in our sale contract. For any warranty claims, please contact an authorized reseller. This warranty does not cover damage due to faulty installation, misuse or inadequate maintenance.***

Dimensions:

E1SBM50I

Length: 1000 mm
Depth: 1000 mm
Height: 900 mm

E1SBM50I/D

Length: 1100 mm
Depth: 900 mm
Height: 900 mm

E1SBM80I

Length: 1500 mm
Depth: 1000 mm
Height: 900 mm

Specifications:

One-piece 18/10 stainless steel supporting chassis, 1 to 3 mm thick, constructed using electric welding.
18/10 stainless steel top frame, 3 mm thick, with a 55 mm front edge flange (upper corner radius 18 mm) and counterfold.
18/10 stainless steel side panels (visible faces), 1 mm thick; assembly with no visible screws.
Recessed gas and electric controls with micro-sandblasted aluminium surface on enamelled steel panels with control symbol markings.
400 mm high legs, situated at the corners of the appliance, made from stainless steel tubing with a diameter of 76.1 mm and with adjustable feet to increase height up to 40 mm.

Tank:

18/10 stainless steel tank with a 10-mm-thick base; built-in front pouring spout, 2.5 mm thick.
18/10 stainless steel lid, 1.5 mm thick, on stainless steel spring hinges; tubular insulated handle.
Retractable wheel and return screw to move the tank's axle for manual tilting.
Safety micro-switch for tilting the tank.
Bratt pans 50dm²:
Internal dimensions (mm): 730 mm x D: 680 mm x H: 250 mm
Bratt pans 80dm²:
Internal dimensions (mm): L:1210mm x D: 680 mm x H: 250 mm

Heating:

Armoured heating elements underneath the tank, 12 kW for 50 dm² bratt pans and 18 kW for 80 dm² bratt pans, voltage 3 ~ 400 V + PE.
Energy regulator control from 0 up to 100% with off position, heating and switched on indicators.
Overheating safety cut out indicator through automatic reset thermostat.



Electric Tilting Bratt pan

Tap:

2 hole mixer, G= 3/4", 120 mm spacing between holes.
1/4 turn tap heads.
Length of swan neck: 300 mm x H: 300 mm, 360° rotation.
Output: 86 l/mn with 3 bars.

Options:

Distinctive tank with bi-metal base, 10 mm thick.
Balanced multi-position lid.

2. PRIOR TO STARTING UP

- a) Prior to starting up, it is advisable to clean the tank in order to eliminate all dust and impurities that have accumulated during storage.

To do this, put 1 to 2 cm of water into the tank, turn it on by selecting the 50 % mark on the energy regulator and leave for about 10 minutes.

- b) Stop preheating.
- c) Empty the tank by tilting it, using the wheel.
- d) Return the tank to a horizontal position, by reversing the process.
- e) Clean the tank with a sponge to eliminate all remaining impurities.

Warnings!

**The bratt pan should not be used for deep fat frying.
Misuse can cause severe damage to the appliance or put surrounding goods and people in danger.
We cannot be held responsible if the user(s) neglect to follow these instructions.**



It is important to turn off before each cleaning.

Do not heat the tank whilst empty for an extended period.

Electric Tilting Bratt pan

3. STARTING UP

The appliance is ON.

- a) Set the energy regulator control knob to the "100" mark (direct heating); the red indicator (the apparatus is heating up) and the yellow indicator (the apparatus is connected) light up.

The preheating phase lasts about 20 minutes; you can start cooking after this period of time.
Temperature is evenly distributed on the cooking plate to allow cooking operations across the whole surface.

TEMPERATURES, RECOMMENDED PREHEATING TIMES, TYPES OF COOKING*

| ENERGY REGULATOR POSITION | COOKING TEMPERATURES | PREHEATING TIMES | PRODUCTS (FRIED FOODS) |
|---------------------------|----------------------|------------------|------------------------|
| 60% - 70% | 150° - 170° | 15' - 20' | FISH |
| 70% - 80% | 180° - 200° | 20' - 25' | WHITE MEATS |
| 80% - 100% | 220° - 250° | 25' - 30' | RED MEATS |

| ENERGY REGULATOR POSITION | BOILING | PREHEATING TIMES | PRODUCTS (wet cooking) |
|---------------------------|---|------------------------------|------------------------------|
| 100% | 100° C | As per capacity 30' - 40' | Vegetables Rice |
| Settings from 20% to 60% | 70°C - 80° C (keeping warm, simmering) | - | Meats in sauce Vegetables |

This information is only indicative*

PRACTICAL ADVICE:

You can cook various types of foods with the bratt pan: sauté foods, grill foods, wet cooking methods for vegetables, rice, pasta, etc.
Lift the lid for all dry and fat cooking methods; close it for all wet cooking methods, simmering methods, etc.

During tilting operations, a tilting tank safety device stops the heat automatically.

In spite of the fact that you can grill foods with the bratt pan, we recommend that you grill the foods with an appropriate grilling appliance.

Warning:

When opening the lid during "wet" cooking operations, be careful of the escaping steam to avoid any risk of burns as the arm passes over the tank.

When emptying:

- *Stay clear of the cooked product pouring zone: risk of splash burns.*
- *Move with the tank to control pouring in the spout area.*
- *Tilt the tank backwards to its idle position to avoid spillage of products when changing receiver containers.*

The tank sides may be very hot after an intensive and long period of use; only use the tilting wheel/handle to tilt the tank.

4. SWITCHING OFF

Bring the energy regulator to the "0" mark.

Clean the tank after each use to remove all residues and liquids.

At the end of the day, switch off electricity at the mains.

CHARVET

38850 - CHARAVINES
Tel.: (33)-4-76-06-64-22
Fax: +33 (0) 4 76 55 78 75
Email: info@charvet.fr



MANUAL AEROGAM EN ESB;
ind.: B; Created on: 14/08/2002
Updated on: 18-12-2013
Page: 13/15

Electric Tilting Bratt pan

5. SERVICING

WARNING

This appliance must not be cleaned by splashing water on it or by high pressure water.

5.1. Cleaning of the stainless steel surfaces:

Wash with a sponge and soapy water (or any other neutral cleaning product).

Do not use bleach or any other acidic product - even well diluted.

For the tops, use a nylon scouring pad if necessary. Always go with the grain.

After each cleaning, rub with an oily rag.

Finger marks can be removed with a cloth dabbed with alcohol.

5.2. Cleaning the tank:

a) Switch off the appliance.

Wait until the apparatus has cooled down before doing anything to it.

b) Fill the tank with warm water and cleaning agent. Scrub the sides and base of the tank using a sponge or a scouring pad.

c) Rinse with warm water, dry the tank and close the lid.

For best results, have your equipment serviced and cleaned on a regular basis by a qualified installer.

Caution: Certain parts of this appliance are protected by the manufacturer, and must not be handled by the installer or the user.

6. TROUBLESHOOTING

UNSATISFACTORY HEATING: Probable causes

The switched on indicator is alight but the tank is not heating up:

- . Badly positioned tank: manoeuvre the tank to engage the positioning microswitch, using the tilting wheel
- . Energy regulator failure
- . Overheat thermostat failure (regulation indicator off)
- . Faulty heating contactor

HEAT BADLY DISTRIBUTED:

- . Faulty heating elements

Contact the supplier to replace the parts or heating elements for further use.





Only a qualified electrician can replace the faulty electric parts.

The manufacturer and the installer cannot be held responsible if the user neglects to ask for assistance in case of breakdown.

Electric Tilting Bratt pan

7. DATA PLATE OF YOUR APPLIANCE

This information will help you with maintenance problems and spare parts.

| | | | |
|---|----------------------|-------------------------|----------------------|
|  | | CHARVET S.A. | |
| | | 38850 CHARAVINES | |
| Réf. | <input type="text"/> | | |
| Code: | <input type="text"/> | Type: | <input type="text"/> |
| N°FC: | <input type="text"/> | | <input type="text"/> |
| N°OF: | <input type="text"/> | Rep. | <input type="text"/> |
| Cat. | <input type="text"/> | <input type="text"/> | <input type="text"/> |
| Gaz | <input type="text"/> | <input type="text"/> | <input type="text"/> |
| P (mbar) | <input type="text"/> | <input type="text"/> | <input type="text"/> |
| ΣQ_n (kW) | <input type="text"/> | <input type="text"/> | <input type="text"/> |
| ΣV_n (m ³ /h) | <input type="text"/> | <input type="text"/> | <input type="text"/> |
| ΣM_n (kg/h) | <input type="text"/> | <input type="text"/> | <input type="text"/> |
| U | <input type="text"/> | V | <input type="text"/> |
| | | Hz | <input type="text"/> |
| P | <input type="text"/> | kW | <input type="text"/> |
|  | | <input type="text"/> | |
| MADE IN FRANCE | | | |

