

GAS-FIRED SOLID TOP

Series: MODUL 1000

FULL MODULE UNIT

Solid top plate



HALF MODULE

Solid top plate

- √ **V00664 - 0696: MODUL1000 G1PL, B-G1PL**
- √ **V00666 - 0698 : MODUL1000 G2PL, B-G2PL**
- √ **V02010: ½MODUL1000 B-G1PL**

INSTALLATION MANUAL



GAS-FIRED SOLID TOP

SUMMARY

INSTALLATION MANUAL	1
1. INSTALLATION	3
1.1. General points	3
1.2. Handling	3
1.3. Installation	3
1.4. Fixing the flue	3
1.5. Gas connections	4
1.6. Power connection	4
2. CONVERSION TO OTHER TYPES OF GAS	5
2.1. Changing the injectors	5
2.1.1. Large solid top plate	5
2.1.2. Small solid top plate	6
2.1.3. Oven	6
2.1.4. Pilot lights	6
2.2. Adjusting the air	7
2.2.1. Solid top plate	7
2.2.2. Oven	7
2.3. Checks before connecting electrically the apparatus	7
2.3.1. Adjustments	7
2.3.2. Starting up	8
3. SERVICING	9
4. BASIC SPARE PARTS LIST	11
5. WIRING DIAGRAMS	13



GAS-FIRED SOLID TOP

1. INSTALLATION

1.1. General points

Installation must be undertaken in compliance with the following instructions and with local codes and bylaws. Ensure you have a suitable and sufficient risk assessment in place.

The user's manual must be given to the user after installation.

1.2. Handling

It is imperative to leave the appliance on its wooden pallet for handling on site until the final installation.

Unpack and check the appliance for damage upon receipt.

In case of damage, mark delivery note accordingly and immediately (within 48 hours) notify the carrier by registered mail with acknowledgement of receipt. Notify your seller.

1.3. Installation

SEE technical sheets.

The appliance must be installed under a suitable mechanical extraction hood.

If this is not the case, they must be protected by an approved fireproof, insulating material.

All local fire regulations must be adhered to.

If in doubt of fireproof construction of adjacent walls, distance to combustible material shall be no less than 10 cm.

- Remove all plastic protection.

Install the flue on top of the appliance and ensure the flue is free of obstruction.

- **Fixed appliance:**

- Install the feet (they are delivered in a box kept inside the appliance).
- Adjust height to level the unit to a horizontal working plan of 900 mm.

- **Mobile appliance:**

- Install the appliance close to the gas mains.

IMPORTANT: The castors with brakes must be locked when the appliance is being connected and during cooking times. Fix all independent half modules against the wall.

1.4. Fixing the flue

Unscrew the screws to lower the fixing tabs,
Help yourself with an appropriate tool to push the fixing tabs,
Tighten the screws of the flue cover.



GAS-FIRED SOLID TOP

1.5. Gas connections

Installation must be undertaken in compliance with the following instructions and with local codes and bylaws. Ensure you have a suitable and sufficient risk assessment in place.

This appliance is of A-type and shall not be connected to a flue gas pipe.

It requires a fresh air input of 2m³/h per 1 kW.

SEE "Adjusting charts" § 2.



Materials, assembly and welding tools must be in compliance with the standard EN 45 204.

- **Fixed appliance:**

Connect the appliance to the gas mains using 1/2" NPT pipe and connections. Install a suitable shutoff valve (or valve + pressure regulator) in the supply line, allowing the unit to be isolated from the rest of the cooking range.

- **Mobile appliance:**

Connect the appliance to the gas mains using 1/2" NPT pipe and connections. Install a suitable shutoff valve (or valve + pressure regulator) in the supply line, allowing the unit to be isolated from the rest of the cooking range.

- **Before connecting the appliance, make sure that:**

The gas supply pipe is of the correct size for minimum pressure drop as a function of length, elbows, and total unit capacity.

Ensure that the appliance is set for the type of gas supplied (nature/pressure); see data plate on the appliance and label on the gas connection.

1.6. Power connection

Power connection will be used if the appliance is fitted with electrical devices.

Installation must be undertaken in compliance with the following instructions and with local codes and bylaws. Ensure you have a suitable and sufficient risk assessment in place.



Use a standardized cable (245 IEC 57 or 245 IEC 66) or other approved cable with the same characteristics.



GAS-FIRED SOLID TOP

- **Fixed appliance:**

The appliance being constantly connected to a fixed electric source, this source will have to be fitted with a suitable leakage currents protective device.

- **Mobile appliance:**

The appliance being connected to a cable fitted with a power-match electrical plug, the socket should be accessible at all times.

- **Before connection :**

- Check that the supply voltage is compatible with the voltage of the appliance (see data plate).
- Check that the electric network is equipped with all-pole circuit breakers having a cross section of 3.5 mm, and complies with the European Standard EN 60335-1 dated of May 2003.

The apparatus is wired at the factory if it has the following options:

- Electric ignition: single phase 230V + Earth (1 ~ 230 V + PE).
- Electric hot cupboard GN 2/1: THREE-PHASE 400 V + Earth (3 ~ 400 V + PE).
- Electric hot cupboard GN 1/1: single phase 230V + Earth (1 ~ 230 V + PE).

2. CONVERSION TO OTHER TYPES OF GAS

In case there is a different type of gas on site.

2.1. Changing the injectors

See charts below according to the type of burners:

- Choose the correct diameter depending on the nature of the gas,
- Get the right air adjustment for the air ring ("d").

Change of gas upon installation: After having replaced the injectors, ensure of the watertightness of the connection between the injector and its support.

2.1.1. Large solid top plate

Air	Gas type & operating pressure	Mark engraved on the injector	Air adjustment d (mm)*2	Nominal calorific output (kW)*1
1	G20: Pn = 20 mbar	280	10	14
2	G 25: Pn = 20 mbar			
3	G 25: Pn = 25 mbar			
4	G 30: Pn = 29 mbar	190	10	
5	G 30: Pn = 50 mbar			
6	G 31: Pn = 37 mbar			
7	G 31: Pn = 50 mbar			
8	G 110: Pn = 8 mbar			
9	G 120: Pn = 8 mbar			

- 1 Measured power over lower calorific power of the gas (HI) for burner.
- 2 Adjustment of measured primary air according to fig. 2



GAS-FIRED SOLID TOP

2.1.2. Small solid top plate

Air	Gas type & operating pressure	Mark engraved on the injector	Air adjustment d (mm)*2	Nominal calorific output (kW)*1
1	G20: Pn = 20 mbar	240	0	10.5
2	G 25: Pn = 20 mbar			
3	G 25: Pn = 25 mbar			
4	G 30: Pn = 29 mbar	160	4.5	
5	G 30: Pn = 50 mbar			
6	G 31: Pn = 37 mbar			
7	G 31: Pn = 50 mbar			
8	G 110: Pn = 8 mbar			
9	G 120: Pn = 8 mbar			

- 1 Measured power over lower calorific power of the gas (HI) for burner.
- 2 Adjustment of measured primary air according to fig. 2

2.1.3. Oven

Air	Gas type & operating pressure	Mark engraved on the injector	Air adjustment d (mm)*2	Nominal calorific output (kW)*1
1	G20: Pn = 20 mbar	280	2	14
2	G 25: Pn = 20 mbar			
3	G 25: Pn = 25 mbar			
4	G 30: Pn = 29 mbar	190	3	
5	G 30: Pn = 50 mbar			
6	G 31: Pn = 37 mbar			
7	G 31: Pn = 50 mbar			
8	G 110: Pn = 8 mbar			
9	G 120: Pn = 8 mbar			

- 1 Measured power over lower calorific power of the gas (HI) for burner.
- 2 Adjustment of measured primary air according to fig. 2

2.1.4. Pilot lights

SOLID TOP / OVEN		
Air	Gas type & operating pressure	Mark engraved on injector
1	G 20: Pn = 20 mbar	40
2	G 25: Pn = 20 mbar	
3	G 25: Pn = 25 mbar	
4	G 30: Pn = 29 mbar	20
5	G 30: Pn = 50 mbar	
6	G 31: Pn = 37 mbar	
7	G 31: Pn = 50 mbar	
8	G 110: Pn = 8 mbar	
9	G 120: Pn = 8 mbar	



GAS-FIRED SOLID TOP

2.2. Adjusting the air

2.2.1. Solid top plate

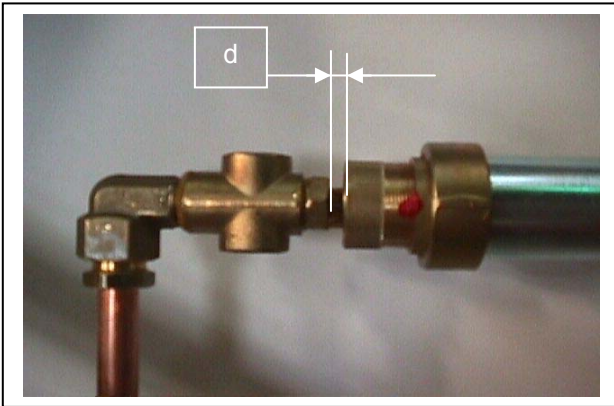

Remove the cast-iron ring plate,

Remove the refractory cement heat retention shielding,

You can reach the air ring and injector

Unlock the air ring (nut/ring),
Change the injector (use a 17mm ring spanner)

Adjust distance "d" and lock (nut/ring), then adjust and seal.

2.2.2. Oven

Remove the mild steel base.

You can reach the air ring and injector.

Unlock the air ring (nut/ring) and push back the air ring to reach the injector.

Change the injector (ring spanner 12mm).

Adjust distance "d" (figure 2) and lock (use à 7 mm open-end spanner).

2.3. Checks before connecting electrically the apparatus

Options: electric ignition, electric hot cupboards.

Before connecting the apparatus, check that:

- The supply voltage is compatible with the voltage of the apparatus,
- The cable is fixed properly,
- The connections are tight enough,
- The apparatus is well earth wired,
- The section of the cable is of correct size according to the voltage of the apparatus,
- All electric parts are well isolated,

2.3.1. Adjustments

Normally, there is no adjustment to do.



GAS-FIRED SOLID TOP

2.3.2. Starting up

Please see the user's manual, section "Starting up".



Never turn on the appliance with empty pans.
Remove all objects from the oven.
All these operations are carried out when the appliance is switched off and cold.

- Connections:

GAS

- Appliances with oven



Threaded tube M 1/2"

Remove the control knobs,
(fixed with M 4-mm needle screws)

Remove the control panel,
(fixed underneath with M 4-mm hexagonal head
screws – use a 7-mm hex key),

Pull the bottom of the panel up and out.

Connect the appliance to the gas mains using a M 1/2"
tube.

- Available as bridge units or with a open base
- half modules

Remove the control knobs,
(fixed with M-4mm needle screws)

Remove the control panel,
(fixed underneath with clips)

Pull the bottom of the panel up and out.

Connect the appliance to the gas mains using a M 1/2" tube.

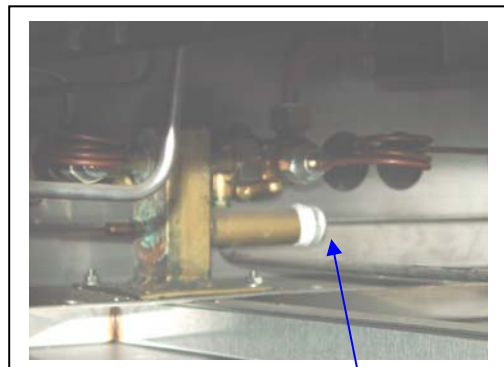

Threaded tube M 1/2"



GAS-FIRED SOLID TOP

ELECTRICITY (options)

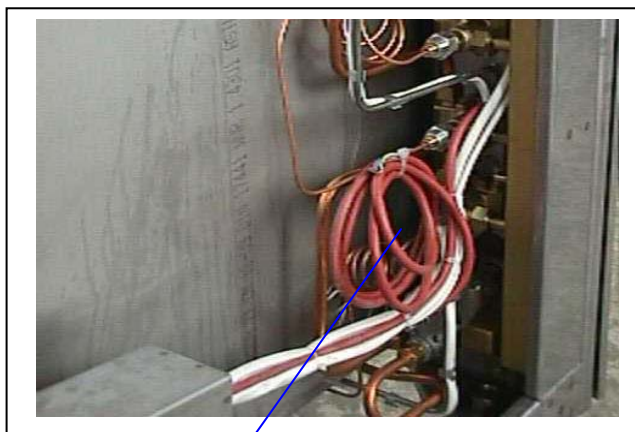

Cable

The appliance is delivered with a high-temperature flexible cable.

Install a standardized plug.

Connect your appliance on a standardized socket.

Make sure the socket is well protected at the distribution board.

- Check the electrical equipment is properly insulated (cable condition).



All appliances must be earth wired.
It is dangerous to connect the appliance unless it is earthed.
We cannot be held responsible for accidents due to non existent or incorrect earth link connection.

WIRING DIAGRAMS:

Option	Voltage	Wiring diagrams #
Electric ignition	1 ~ 230 V + E	SE0001 / 00
Electric hot cupboard GN 2/1	3 ~ 400 V + E	SE0006 / 00
Electric hot cupboard GN 1/1	1 ~ 230 V + E	SE0005 / 00

3. SERVICING



Any technical action on an appliance must be undertaken by a qualified technician.
The appliance will be isolated from the gas mains by closing the gas valve.
The appliance will have to be isolated from the electrical supply for the duration of the work.

When the appliance is ready for use, ensure the users know how to use it properly (See the "User's Manual").

Formerly give the person in charge of the kitchen all documentation needed.



GAS-FIRED SOLID TOP

Each appliance has its own data plate. Transfer all the information written on the data plate to the part of the user instructions booklet reserved for it.



This will ease the communication between you and your client for better service.

WARRANTY:

The warranty is mentioned in our conditions of sale.

This warranty does not cover damage due to faulty installation, misuse or inadequate maintenance.







GAS-FIRED SOLID TOP

4. BASIC SPARE PARTS LIST

Description	Code	Photograph	Description	Code	Photograph
Pilot light	07151A		Oven injectors φ 1.90 Propane φ 2.80 Natural	06985A 00212A	
Injector (large solid top) φ 1.90 Propane φ 2.80 Natural	06985A 00212A		Injector (small solid top) Φ 1.60 Propane Φ 2.40 Natural	00200A 00208A	
Electrode Solid top plate Oven	05315A		Water taps: Oven Solid top, oven, griddle Open base	00503A 05226A 00502A	
Thermocouple Solid top plate Oven	00291A 00290A		Coil thermocouple valve	00325A	
Connection cable High Voltage electrode / transformer	05317A		Ignition transformer	02161A	
Thermostatic control for oven ST 35 (BJWA unavailable)	00295A 08425A		Injectors for pilot light Ø 0.20 Propane Ø 0.40 natural	01157A 06430A	



GAS-FIRED SOLID TOP

Description	Code	Photograph	Description	Code	Photograph
Ring (small solid top plate)	05192A		Ring set (large solid top plate)	05213A	
Solid top plate 480 x 300 mm	05170A		Solid top plate 900 x 600 mm	05171A	
Oven mild steel base	F00164				



GAS-FIRED SOLID TOP

5. WIRING DIAGRAMS

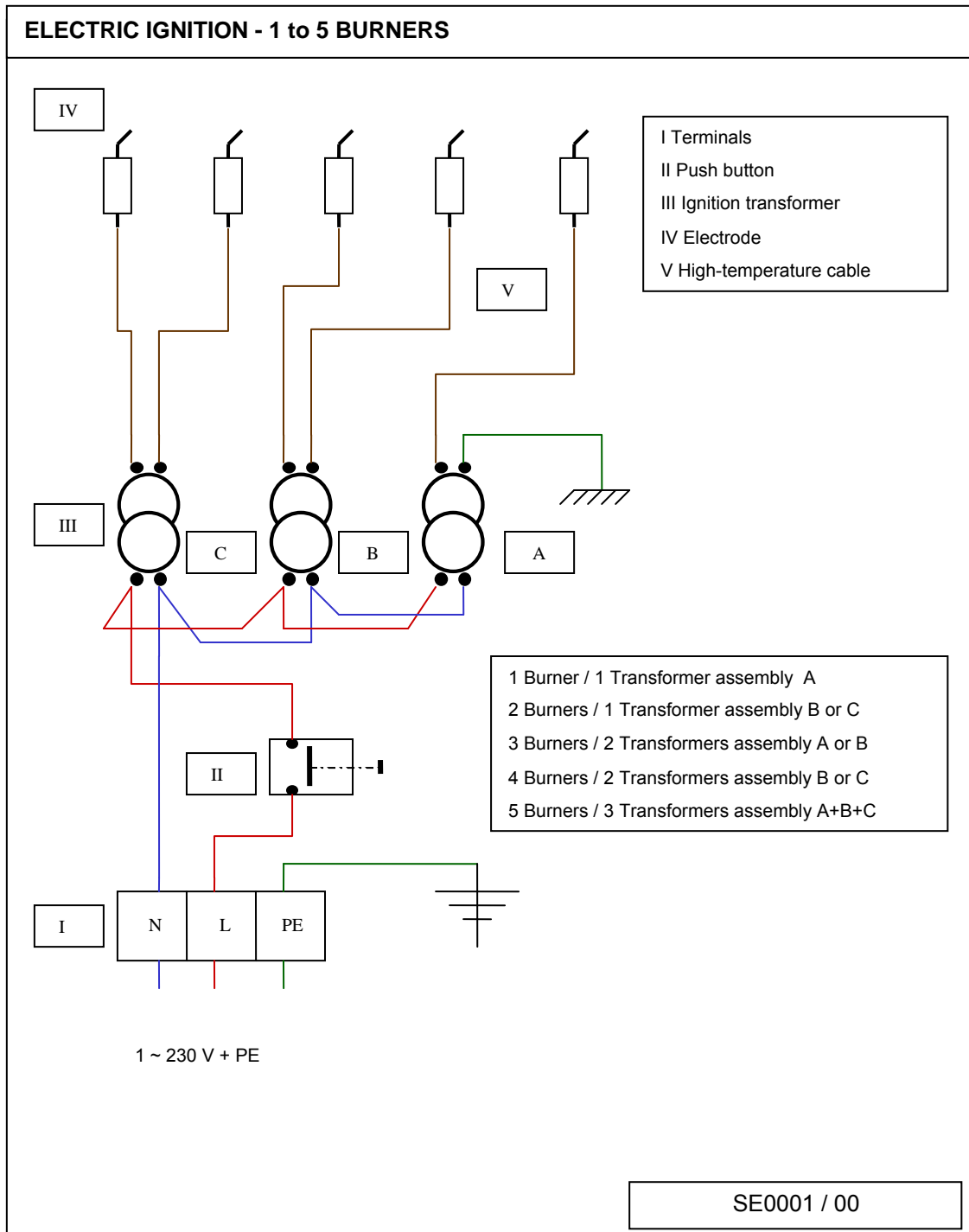

GAS-FIRED SOLID TOP

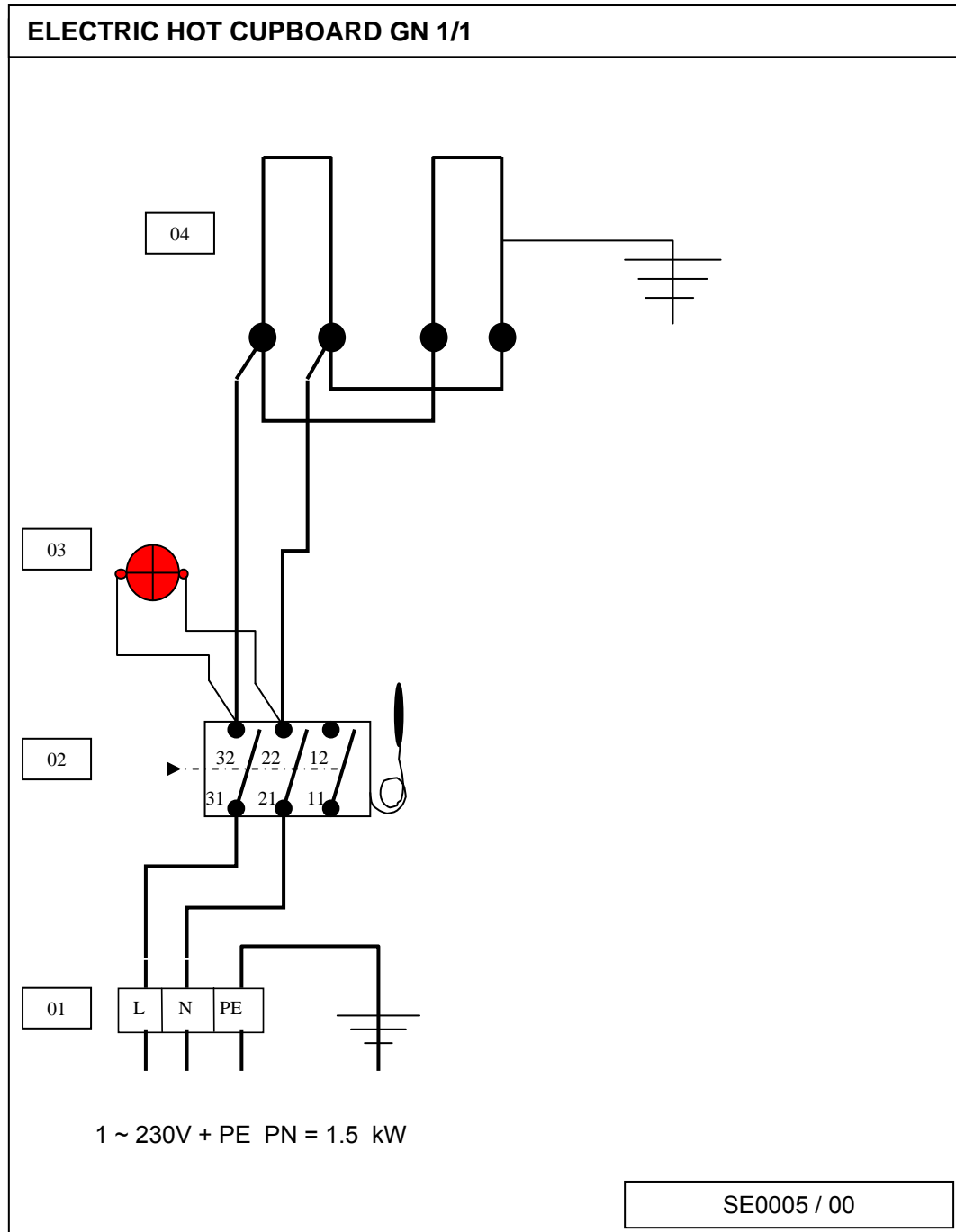

NOMENCLATURE: ELECTRIC HOT CUPBOARD GN1/1 (SE0005 / 00)

Mark	Code	Description	Quantity
01	02468A	10 mm ² terminal (brand: Viking)	1
01	07069A	Blue terminal Vicking	1
01	03575A	Earth terminal (brand: Viking)	1
02	01995A	Thermostat	1
03	02141A	Bulb 230 V	1
03	02131A	Red indicator	1
04	02060A	heating elements	2



GAS-FIRED SOLID TOP

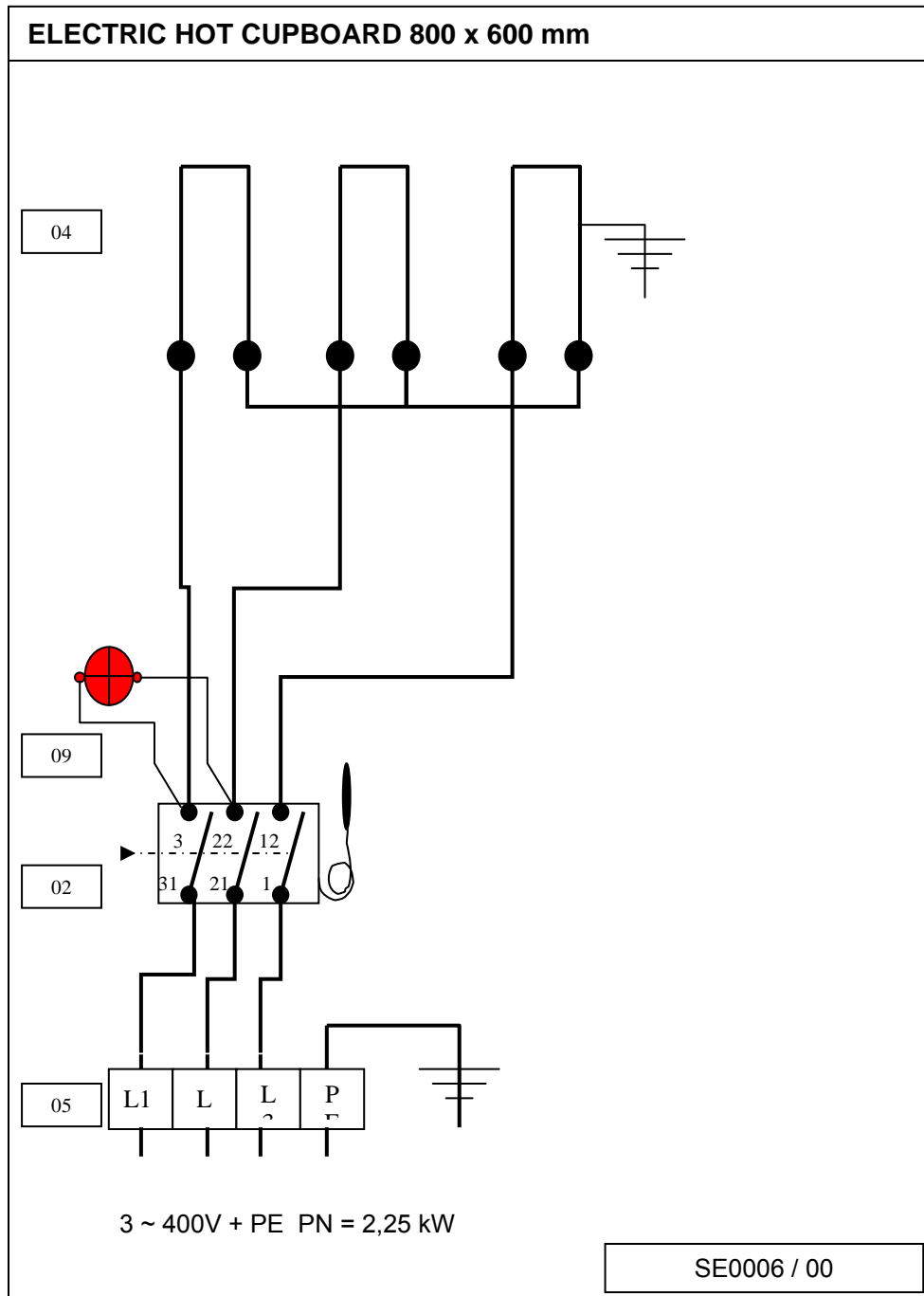

NOMENCLATURE: ELECTRIC HOT CUPBOARD 800 mm x 600 mm (wiring diagram: SE0006 / 00

Mark	Code	Description	Quantity
01	02468A	10 mm ² terminal (brand : Viking)	3
01	03575A	Earth terminal (brand: Viking)	1
02	01995A	Thermostat	1
03	02142A	Bulb 400 V	1
03	02131A	Red indicator	1
04	02060A	Pin heating element – 750 W, 230 V	3



GAS-FIRED SOLID TOP

Series: MODUL1000

FULL MODULE UNIT

Solid top plate



HALF MODULE

Solid top plate

- √ V00664 - 0696: MODUL1000 G1PL, B-G1PL
- √ V00666 - 0698: MODUL1000 G2PL, B-G2PL
- √ V02010: ½MODUL1000 B-G1PL

USER'S INSTRUCTIONS



GAS-FIRED SOLID TOP

SUMMARY

USER'S INSTRUCTIONS	1
1. INTRODUCTION	3
2. PRIOR TO STARTING UP	4
3. STARTING UP	5
3.1. Solid top plate	5
3.2. Oven	5
4. SWITCHING OFF	6
5. MAINTENANCE	6
5.1. Cleaning the stainless steel surfaces	6
5.2. Cleaning the solid top plate	7
5.3. Cleaning the oven	7
6. IN CASE OF BREAKDOWN	7
7. DATA PLATE	8



GAS-FIRED SOLID TOP

1. INTRODUCTION

- A) Our equipment is for professional use only and must be used by qualified staff.
- B) The equipment must be installed in compliance with local codes and bylaws. It must be installed in a kitchen equipped with an adequately sized mechanical extraction system.
- C) Appliances may be installed side by side or against walls of non combustible material. Distance to combustible material shall be no less than 10 cm.
- D) It is imperative to call for a qualified engineer for all new installations or modifications of existing equipment.
- E) This instruction manual is contractual and must be given to the user after installation.
- F) ***WARRANTY:*** *The warranty is mentioned in our conditions of sale. Only a qualified engineer certifies the validity of the warranty. This warranty does not cover damage due to faulty installation, misuse or inadequate maintenance.*

Dimensions:

Full module unit:

Length: 1000 mm.
Depth: 1000 mm.
Height: 900 mm.

Half module unit:

Length: 500 mm.
Depth: 1000 mm.
Height: 900 mm.

Specifications:

One-piece seam welded 18-10 stainless steel chassis, 1 to 3 mm thick.
18-10 stainless steel top frame, 3 mm thick, with a 55 mm high edge having a 18 mm radius and return to underside.
18-10 stainless steel flue.
18-10 stainless steel side panels, 1 mm thick; assembly with no visible screws.
Enameled steel control panel with control symbol markings.
Recessed gas controls.
Thermostatic valve for oven temperature regulation.
Control knobs in micro-sandblasted aluminium.
18-10 stainless steel legs, 200 mm high, with adjustable PVC feet, diameter 60.3 mm, adjustment +10/-20 mm.
Oven folded handle in enameled steel fitted on micro-sandblasted aluminium supports.



GAS-FIRED SOLID TOP

Top:

MODUL1000 G1PL, B-G1PL:

One two-piece cooking plate (980 x 600 mm) with a centered set of rings.
"Crown-burner" rated 14 kW on refractory cement heat retention shielding - stainless steel support.
Pilot light and safety thermocouple integrated to the burner.
18-10 stainless steel drip tray in front.
Removable refractory shielding surrounded by stainless steel housing.

MODUL1000 G2PL, B-G2PL:

Two two-piece cooking plates (480 x 600 mm) with a centered ring.
"Crown-burners" rated 10.5 kW on refractory cement heat retention shielding - stainless steel support.
Pilot lights and safety thermocouples integrated to the burners.
18-10 stainless steel drip trays in front.
Removable refractory shieldings surrounded by stainless steel housing.

½MODUL1000 B-G1PL:

One two-piece cooking plate (480 x 600 mm) with a centered ring.
"Crown-burner" rated 10.5 kW on refractory cement heat retention shielding - stainless steel support.
Pilot light and safety thermocouple integrated to the burner.
18-10 stainless steel drip tray in front.
Removable refractory shieldings surrounded by stainless steel housing.

Base: Static oven

Dimensions (mm): L: 600, D: 800, H: 300.
"Multi-ramps" burner in in enamelled steel rated 14 kW.
Pilot light and safety thermocouple integrated to the burner.
Regulation thermostat (50-300°C).
Mild steel base, 6-mm thick.
Insulated stainless steel muffle with stainless steel protection.
Removable 3-position enamelled steel shelf runners with a 70-mm space.
18-10 stainless steel door and indoor with rock wool insulation - handle in enamelled steel on aluminium support.
Equipped with one GN 2/1 nickel coated wire oven shelf (600 x 800 mm) with anti-tilt supports.

Options:

Electric ignition of the burners.
Electric hot cupboard GN 1/1 & GN 2/1.

2. PRIOR TO STARTING UP

- a) Prior to starting up, it is advisable to clean the appliance in order to eliminate all dust and impurities that have accumulated during storage.
- b) Remove all plastic protection that wraps the stainless steel panels.
- c) Make sure that all controls are in good working condition before turning the gas on.



GAS-FIRED SOLID TOP

3. STARTING UP

General points: Each burner is equipped with a safety thermocouple and a pilot light.

3.1. Solid top plate

Take off the central ring.

Close the oven door.

Push and turn the control knob counter-clockwise of desired burner (fig. 1, mark "P") until the spark symbol.

Keep pushing thoroughly while presenting a flame or pressing the ignition push button (if fitted).

Keep the control knob pressed for 5 to 15 sec. before releasing it,

The pilot light must remain ignited, Repeat the operation if it fails,

When the pilot light is on, turn the control knob counter-clockwise to the "full power" position (large flame symbol); the burner is running at its nominal power.

By turning the control knob to the next position (small flame symbol), the burner is on the slow-down position (simmering position).

When done, refit the central ring.

3.2. Oven

Check that you can reach the pilot light through the oblong hole located at the front left hand side of the mild base (above the pilot light).

Push and turn the control knob counter-clockwise of desired burner (fig. 1, mark "F") until the spark symbol.

Keep pushing thoroughly while presenting a flame through the mild steel base hole or pressing the ignition push button (if fitted).

Keep the control knob pressed for 5 to 15 sec. before releasing it,

The pilot light must remain ignited, Repeat the operation if it fails,

When the pilot light is on, turn the control knob counter-clockwise to the desired position (large flame symbol).

Turn the thermostat control knob (Figure 1, mark T) to the desired temperature; the oven burner is working at its full power.

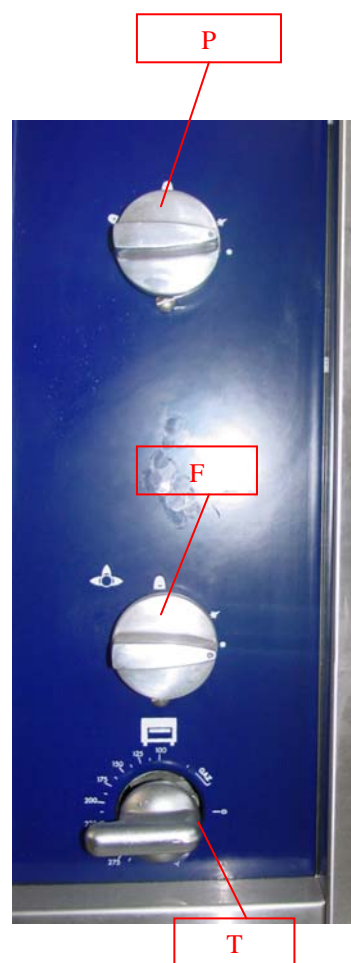

Figure 1

GAS-FIRED SOLID TOP

TEMPERATURES, RECOMMENDED PREHEATING TIMES, TYPES OF COOKING*

THERMOSTAT SETTINGS	PREHEATING TIMES	PRODUCTS
80°C - 100°C	20"	Holding temperature
120°C - 140°C	30" - 40"	Pastry
150°C - 170°C	1' - 1'30	FISH
190°C - 220°C	2' - 3'	WHITE MEATS
240°C - 260°C	4' - 6'	Gratins
270°C - 310°C	7' - 9'	RED MEATS

**These figures are only indicative.*

PRACTICAL ADVICE

Do not forget to place a drip pan when cooking directly on the oven shelf.

The shelf runners allow the dishes to be levelled and centred.

Warm the oven before starting to cook (see the chart above).

WARNING!

Be careful of steam escaping when opening the oven door after "wet" cooking process. Serious risks of burns!

Side panels and oven door may be extremely hot after a prolonged or intensive use. Be careful to open the door only with the handle, and stay clear from the door.

4. SWITCHING OFF

Turn control knobs and oven thermostat to the "STOP" positions: ● & 0.

Before doing anything on the appliance, wait until cooking areas has cooled down.

Clean the oven, the oven shelf, the grease collection drawer, and the drip tray after each use - in order to remove food particles and liquids.

At the end of the day, cut off gas supply or/and switch off electricity at the mains (or disconnect from the wall socket).

5. MAINTENANCE

5.1. Cleaning the stainless steel surfaces

Switch off the appliance.

Wait until the apparatus has cooled down before doing anything on it.

Wash with a sponge in soapy water (or any other neutral cleaning product).

Do not use bleach or any other acidic product – even well diluted.

For the tops, use a nylon scouring pad if necessary. Always go with the grain.

After each cleaning, rub with a greased cloth or kitchen paper.

Finger marks can be removed with a cloth dabbed with alcohol.



GAS-FIRED SOLID TOP

5.2. Cleaning the solid top plate

Clean with an appropriate scouring pad. Grease the cast-iron plate(s) if you don't use the appliance.
Remove the solid top plate(s) to clean the refractory cement heat retention shielding.
The drip tray should be cleaned daily.
Refit in order all the parts.

5.3. Cleaning the oven

To avoid fumes due to greases, stains and food particles, we recommend you to clean all the oven internal sides every day.

The mild steel base can be removed to be cleaned. The burner housing can be cleaned as well.

The shelf runners can also be removed to be cleaned.

Wash the oven with a sponge in soapy water (or any other neutral cleaning product).

After cleaning, rinse and dry all the parts carefully.

Refit in order all the parts.



Clean the solid top with a Tampico brush or a wood spatula.

Never clean the cast iron solid top plate with ice.

Dry the cooking plate very carefully to avoid rusting. Then clean with a greasy cloth.

Our equipment must not be cleaned with water under pressure or be subjected to a deluge of water splashes (the burner can be damaged).

Check that the appliance is well disconnected at the mains.

For best results, have your equipment serviced and cleaned on a regular basis by a qualified installer.

WARNING: Certain parts of this appliance are protected by the manufacturer, and must not be handled by the installer or the user.

6. IN CASE OF BREAKDOWN

UNSATISFACTORY HEATING: Probable causes

- Clogging of the burners, injectors, etc.
- Incorrect gas pressure.
- Incorrect grading of the injectors.
- Clogging of the rear internal flue box (solid top plate(s), oven).
- Incorrect oven temperature: Faulty thermostat.

FAULTY IGNITION:

- Clogging of the pilot lights.
- Clogging of the thermocouples.
- Smashed thermocouple, incorrect pilot light output and positioning, and insufficient pressure on control button.
- Faulty electric ignition (option).
- Call for your installer to replace the faulty electric components in preparation for a next use.



Only a qualified electrician can replace the ignition transformers.

The manufacturer and the installer cannot be held responsible if the user neglects to ask for assistance in case of breakdown.





GAS-FIRED SOLID TOP

7. DATA PLATE

TRANSFER below information written on the data plate of your appliance.

This will help you with maintenance problems and spare parts.

		CHARVET S.A.	
		38850 CHARAVINES	
Réf.	<input type="text"/>		
Code:	<input type="text"/>	Type:	<input type="text"/>
N°FC:	<input type="text"/>		<input type="text"/>
N°OF:	<input type="text"/>	Rep.	<input type="text"/>
Cat.	<input type="text"/>	<input type="text"/>	<input type="text"/>
Gaz	<input type="text"/>	<input type="text"/>	<input type="text"/>
P (mbar)	<input type="text"/>	<input type="text"/>	<input type="text"/>
ΣQ_n (kW)	<input type="text"/>	<input type="text"/>	<input type="text"/>
ΣV_n (m ³ /h)	<input type="text"/>	<input type="text"/>	<input type="text"/>
ΣM_n (kg/h)	<input type="text"/>	<input type="text"/>	<input type="text"/>
U	<input type="text"/>	V	<input type="text"/>
		Hz Ip	<input type="text"/>
P	<input type="text"/>	kW	<input type="text"/>
	<input type="text"/>		
MADE IN FRANCE			

