

GMC MODULE UNIT

Description	EXTEND CONCEPT
GMC0030	Module 1300
GMC0033	
GMC0156	



Installer's Instructions

CHARVET

F-38850 – CHARAVINES
Tel.: +33 (0) 4-76-06-64-22
Fax: +33 (0) 4-76-55-78-75
Email: info@charvet.fr
Email: sav@charvet-sa.fr



MANUAL: GMC 1300 4 OPEN BURNERS
Ind. A; Created on: 15.05.2009
Updated on:

SUMMARY

1. INSTALLATION	3
1.1. GENERAL POINTS.....	3
1.2. HANDLING	3
1.3. INSTALLATION.....	3
1.4. DATA PLATE	4
2. GAS CONNECTIONS	4
2.1. CHECKS BEFORE CONNECTION	4
2.2. CONNECTING THE APPLIANCE TO THE GAS MAINS	5
2.3. CHECKS AFTER CONNECTION.....	5
2.4. CHECKS OF PRESSURE SUPPLY	5
3. CONVERSION TO OTHER TYPES OF GAS	6
3.1. CHANGING INJECTORS AND ADJUSTING AIR	6
3.2. CHANGING INJECTORS AND ADJUSTING AIR OF OVEN PILOT LIGHT.....	7
3.3. GAS ADJUSTMENT CHARTS.....	8
3.4. ADJUSTING THE OVEN OUTPUT.....	9
3.5. ADJUSTING THE SLOW-DOWN POSITION OF OPEN BURNERS	10
4. POWER CONNECTION	10
4.1. CHECKS BEFORE CONNECTION	10
4.2. CONNECTING THE APPLIANCE	11
4.3. CHECKS AFTER CONNECTION.....	11
4.4. ADAPTING THE APPLIANCE TO THE VARIOUS ELECTRICAL SUPPLIES VOLTAGE	11
5. CONNECTING THE WATER TANK	11
5.1. CHECKS BEFORE CONNECTION	11
5.2. CONNECTING THE APPLIANCE TO THE WATER SUPPLY SYSTEM	12
5.3. CHECKS AFTER CONNECTION.....	12
6. WIRING DIAGRAMS	13
7. BASIC SPARE PARTS LIST	17
8. MAINTENANCE	19
8.1. ELECTRIC OVEN: CHANGING THE HEATING ELEMENT	19
8.2. HOT CUPBOARD: CHANGING THE HEATING ELEMENT	20
8.3. CHANGING THE SOLENOID VALVE	20

1. INSTALLATION

1.1. General points

Installation must be undertaken in compliance with the following instructions and with local codes and bylaws. Ensure you have a suitable and sufficient risk assessment in place.

This appliance is of A-type and shall not be connected to a flue gas pipe.

The user's manual must be given to the user after installation.

1.2. Handling

It is imperative to leave the appliance on its wooden pallet for handling on site until the final installation.

Unpack and check the appliance for damage upon receipt.

In case of damage, mark delivery note accordingly and immediately (within 48 hours) notify the carrier by registered mail with acknowledgement of receipt. Notify your installer.

1.3. Installation

All local fire regulations must be adhered to.

The appliance must be installed under a suitable mechanical extraction hood.

If the apparatus is to be installed against a wall or partition, near a piece of furniture or decorative borders, it is recommended that these are made of fireproof material.

If this is not the case, they must be protected by an approved fireproof, insulating material.

If in doubt of fireproof construction of adjacent walls, distance to combustible material shall be no less than 10 cm.

Remove all plastic protection.

Install the appliance in the kitchen.

Warning



Fixed appliance:

- Check that the masonry plinth is well horizontally leveled.
- Adjust height to level the unit to a horizontal working plan of 900 mm.
- Remove the plinth (fixed with 2 screws) – see Gas Connections § 2.2 – Fig. B (5).

**Any technical action on an appliance must be undertaken by a qualified technician.
The appliance will be isolated from the gas mains by closing the gas valve.**



When the appliance is ready for use, ensure the users know how to use it properly.
(Please see the user's manual).

Warranty: The warranty is mentioned in our conditions of sale.
This warranty does not cover damage due to faulty installation,
misuse or faulty maintenance.

EXTEND CONCEPT GMC 4 OPEN BURNERS

1.4. Data plate

Each appliance has its own data plate. Transfer all this information on the last page of the user's manual. **This will ease the communication between you and your client for better service.**

	
<p align="center">Location of the data plate Inside cupboard / hot cupboard</p>	<p align="center">Inside open base.</p>

2. GAS CONNECTIONS

Warnings

- **Fixed appliance:**

Connect the appliance to the gas mains using 1/2" NPT pipe and connections. Install a suitable shutoff valve (or valve + pressure regulator) in the supply line, allowing the unit to be isolated from the rest of the cooking range.

2.1. Checks before connection

Check:

- The mains should be free of obstructions, and clean.
- Ensure that the gas supply pipe is of the correct size for minimum pressure drop according to length, elbows, and total unit capacity.
- The appliance requires a fresh air input of 2m³/h/kW. (See chart below).
- The type of gas used:
Ensure that the appliance is set for the type of gas supplied (nature/pressure); see data plate on the appliance and label on the gas connection.

CHART			
Code	Appliance	Power (kW)	Fresh air input required (m ³ /h/kW)
GMC0030	1300	43 KW	86 KW
GMC0033		32 KW	64 KW
GMC0156		32 KW	64 KW

EXTEND CONCEPT GMC 4 OPEN BURNERS

2.2. Connecting the appliance to the gas mains

Remove the control knobs, (2) (fixed with screws) Remove the water tap (1),
Unscrew the 2 screws (3) and disengage the control panel.
Connect to connection 20/27 (4) located in the technical space.

Nota: The technical space is behind the control panel.

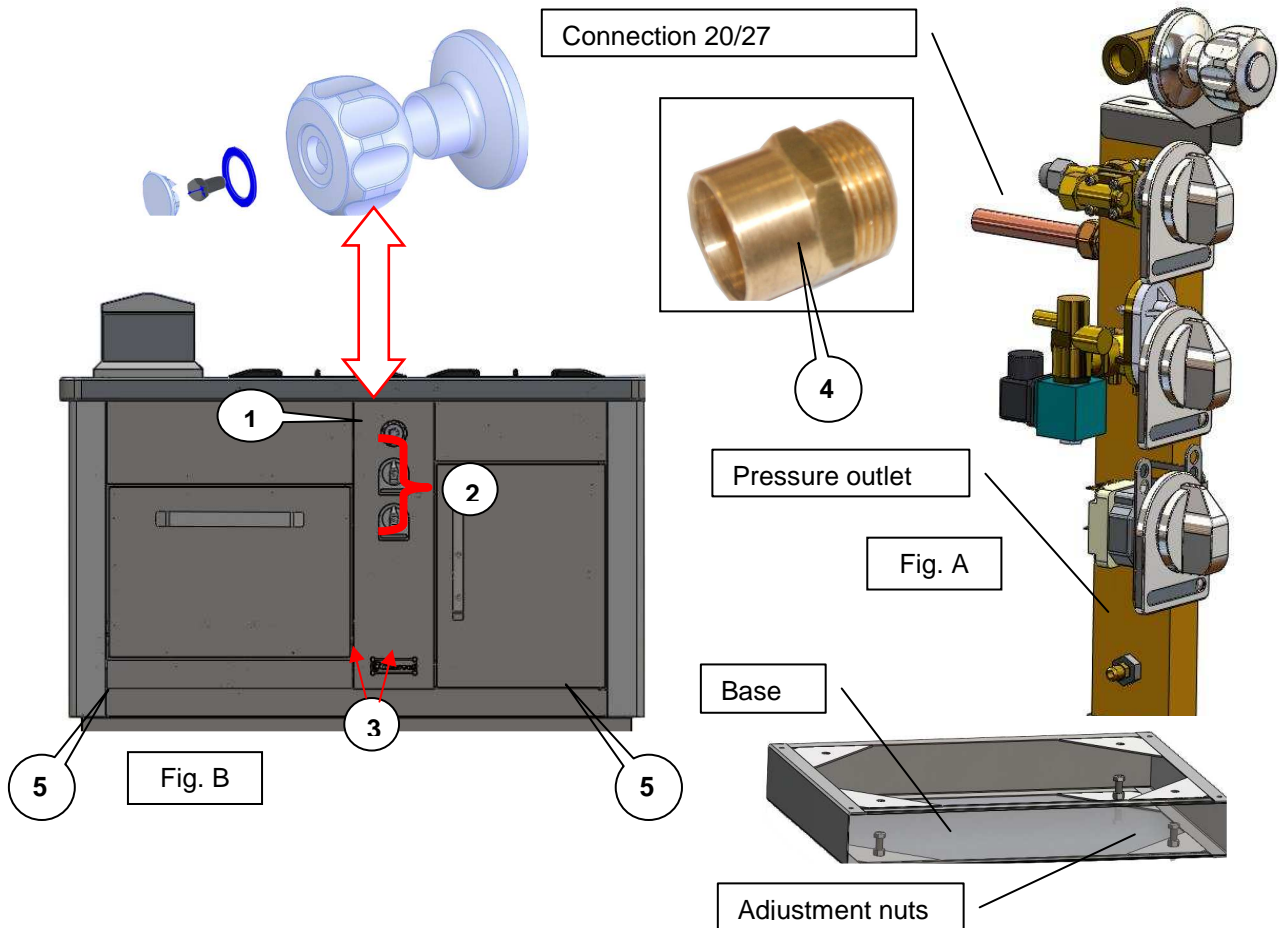

2.3. Checks after connection

- Watertightness of the gas pipe,
- Supply pressure of the appliance in function,
- The colour of the flame (blue),
- The slow-down position (see § 3.4.),
- The good working state of the appliance and its safety devices.

2.4. Checks of pressure supply

Taking the pressure:

- Remove the control knobs,
- Remove the control panel,
- Connect the manometer on the pressure outlet located on the burner ramp,
- Switch ON appliance to maximum setting,
- Then check your figures (see § 3 "Gas Adjustments").

Note: All the appliances connected to the same gas supply should be in working state while taking the pressure supply.

EXTEND CONCEPT GMC 4 OPEN BURNERS

3. CONVERSION TO OTHER TYPES OF GAS

Change of gas upon installation: After having replaced the injectors, ensure of the watertightness of the connection between the injector and its support.

3.1. Changing injectors and adjusting air

See charts § 3.3. according to the type of burners.

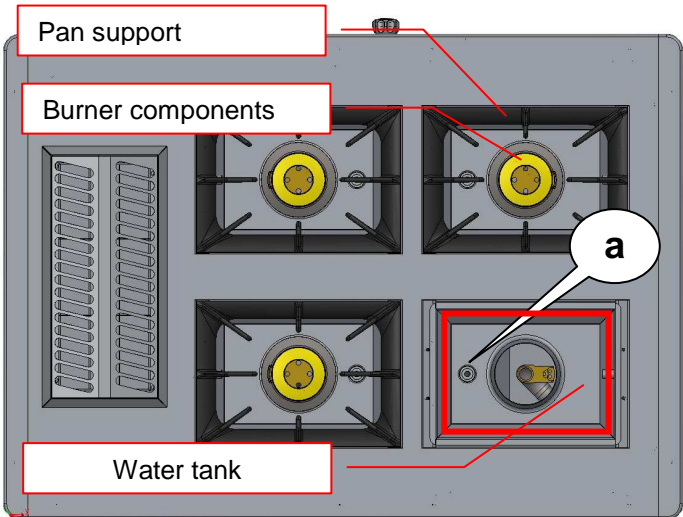
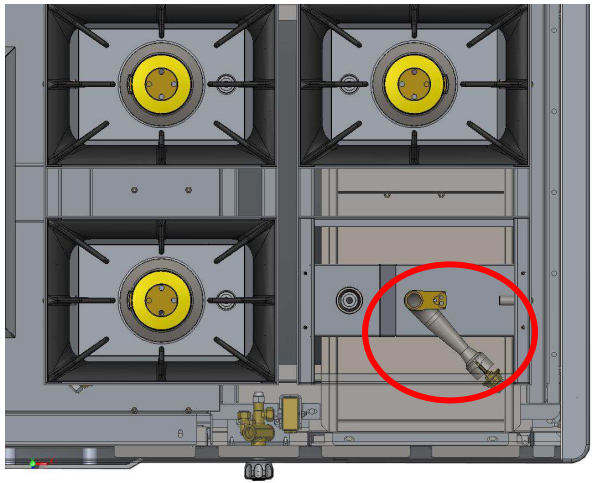
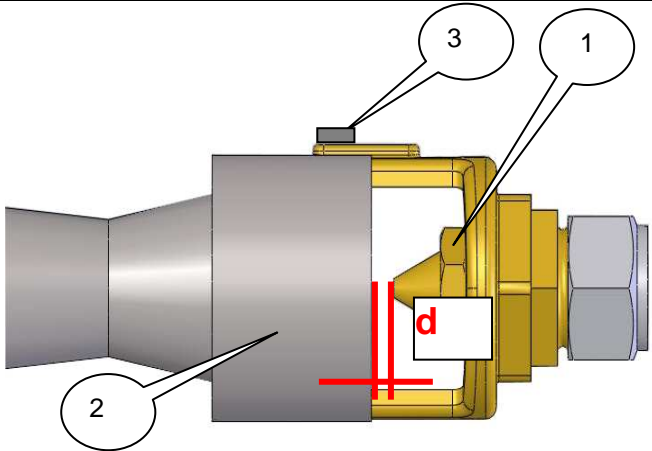
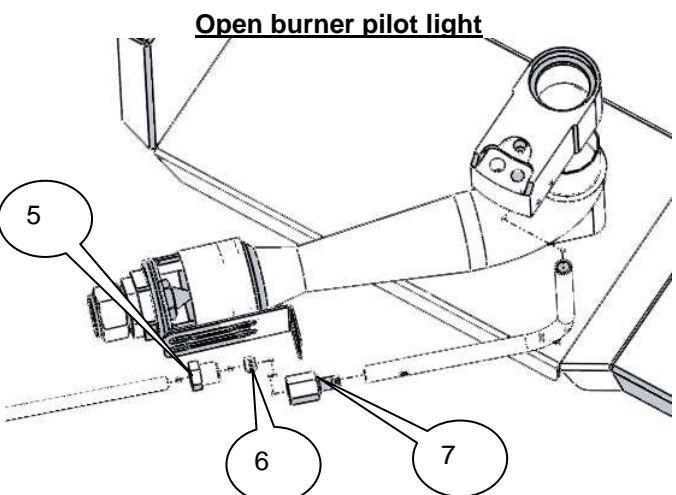
	
	
<p>. GMC Open burners</p> <ul style="list-style-type: none"> - Remove the pan support and burner components (cap, body, tank...) -Unlock the air ring (2), nut (3)/ring -Change the injector (1) (ring spanner 17mm) See chart A § 3.3. -Adjust distance « d », and lock. (nut/ring), then adjust and seal. Note: Refit the sluice gate (a). 	<p><u>GMC injector & pilot light Open burners</u></p> <ul style="list-style-type: none"> -Unscrew the nut (5) -Change the injector (7) (ring spanner 12mm) See chart A § 3.3. -Refit the parts in reverse order: injector (7), olive (6) and nut (5).

3.2. Changing injectors and adjusting air of oven pilot light

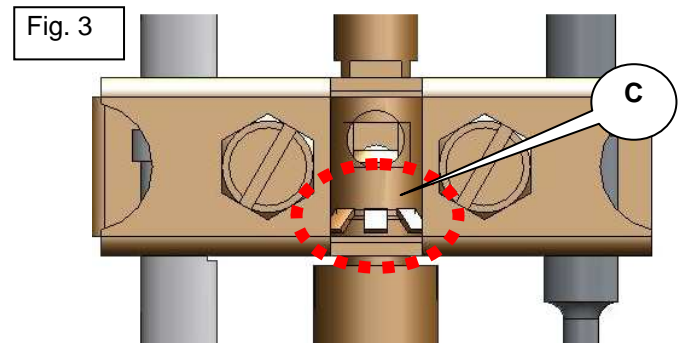
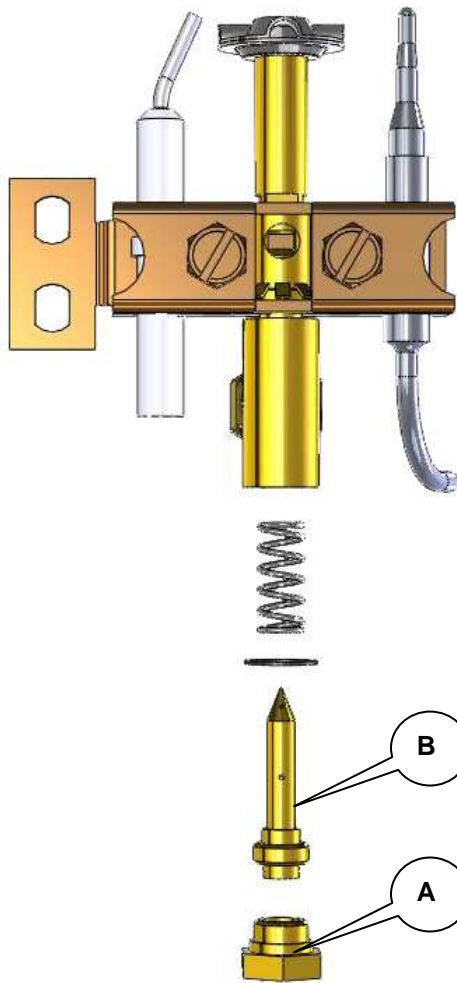

Remove the mild steel base.
Unscrew the nut (A) with an open-end spanner 11mm.
Change the injector (B); see chart § 3.3.
Adjustment of air ring (Fig. 3 (C)); see chart § 3.3.

Check the watertightness of the gas pipe and the good working condition of the pilot light.

EXTEND CONCEPT GMC 4 OPEN BURNERS

3.3. Gas adjustment charts

Open burner Ø Ø110mm			Chart A	
Adjustment	Gas type & operating pressure	Mark engraved on the injector	Air adjustment d (mm)*2	Calorific output (kW)*1
1	G20: Pn = 20 mbar	230	3	8
2	G 25: Pn = 20 mbar			
3	G 25: Pn = 25 mbar			
4	G 30: Pn = 29 mbar	135	Max	
5	G 30: Pn = 50 mbar			
6	G 31: Pn = 37 mbar			
7	G 31: Pn = 50 mbar			

- 1 - Measured power over lower calorific power of the gas (HI) for 1 burner.
- 2 - Adjustment of measured primary air according to fig. 1.

OVEN			Chart B	
Adjustment	Gas type & operating pressure	Mark engraved on the injector	Air adjustment d (mm)*2	Calorific output (kW)*1
1	G20: Pn = 20 mbar	250	2	11
2	G 25: Pn = 20 mbar			
3	G 25: Pn = 25 mbar			
4	G 30: Pn = 29 mbar	170	Max	
5	G 30: Pn = 50 mbar			
6	G 31: Pn = 37 mbar			
7	G 31: Pn = 50 mbar			

Oven pilot light			Chart C	
Adjustment	Gas type & operating pressure	Mark engraved on the injector	Air adjustment	
1	G20: Pn = 20 mbar	40	None	
2	G 25: Pn = 20 mbar			
3	G 25: Pn = 25 mbar	20	None	
4	G 30: Pn = 29 mbar			
5	G 30: Pn = 50 mbar			
6	G 31: Pn = 37 mbar			
7	G 31: Pn = 50 mbar			

Open burner pilot light			Chart D	
Adjustment	Gas type & operating pressure	Mark engraved on the injector	Air adjustment	
1	G20: Pn = 20 mbar	35	None	
2	G 25: Pn = 20 mbar			
3	G 25: Pn = 25 mbar	20	None	
4	G 30: Pn = 29 mbar			
5	G 30: Pn = 50 mbar			
6	G 31: Pn = 37 mbar			
7	G 31: Pn = 50 mbar			

3.4. Adjusting the oven output

Output adjustment is done in factory (Thermostatic control)
 Only qualified staff can do the adjustment.
 It could be necessary to adjust it.

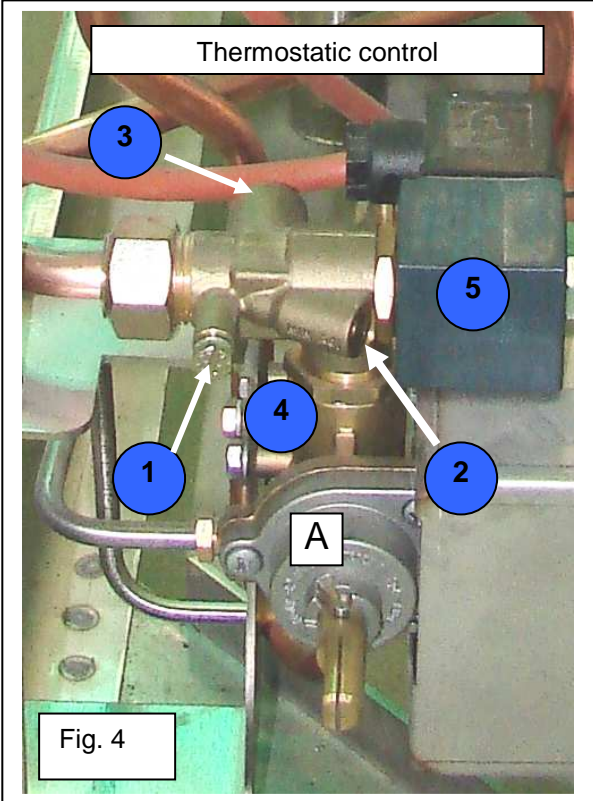

Thermostatic control

Fig. 4

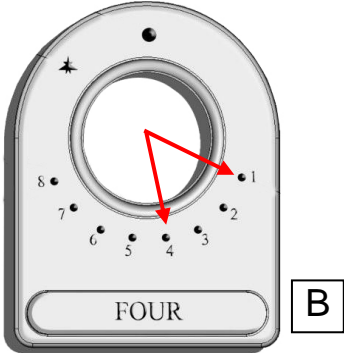

B

This operation must be carried out very quickly and before the thermostat responds and the burner turns to the maxi output position.
Note: The maximum output position reduces the flames to ¼ of their size. The burner must remain alight when proceeding from the maximum output position to the minimum output position.

- 1) Pressure outlet
- 2) Mini output screw
- 3) Maxi output screw
- 4) Thermostatic control

- **Adjusting the oven slow-down position**

Remove the control panel (see "Gas connection" § 2.2.).
 Refit the control knob (A).
 Ignite the burner and preheat for 15mn about with the door closed.
 Thermostatic control in position 3-4 then in position 1 (Fig. B). Screw (3) to reduce output and unscrew to increase it.
 Screw (2) to reduce output and unscrew to increase it.
 Pressure can be measured from the pressure outlet (1) (Fig. 4).

3.5. Adjusting the slow-down position of open burners

Note: The burner must remain alight when changing from maximum output to minimum output. See § “Adjusting the slow-down position”.

Slow-down screw

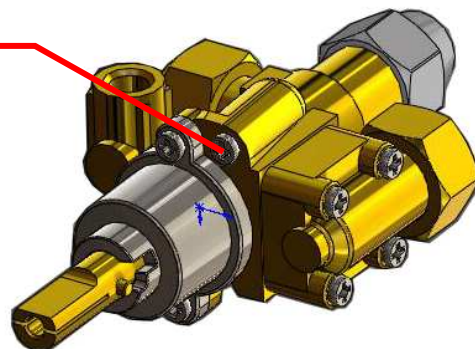

Remove the control knobs,
Remove the control panel,
(see § 2.1. « Gas connection »); Refit the control knob.
Switch ON the appliance (See the user's manual, § 2).
Set control knob to the slow-down position.
Adjust the screw.
To increase the slow-down position, turn counter clockwise.

4. POWER CONNECTION



Warnings:

The appliance must be earth wired.
It is dangerous to connect the appliance unless it is earthed.
We cannot be held responsible for accidents due to non existent or incorrect earth link connection.

Fixed appliance:

Check that the electric network is equipped with all-pole circuit breakers having a cross section of 3.5 mm at least. All electrical equipment must be in compliance with the standard EN 60335-1.

WARNING:

Use a standardized cable (245 IEC 57 or 245 IEC 66) or other approved cable with the same characteristics.

All controls and checks below are done when the appliance is switched off and cold.

4.1. Checks before connection

- The electrical voltage of the supply is compatible with the voltage of the apparatus (see data plate).
- The cable is fixed properly,
- The connections are tight enough,
- The section of the cable is of correct size according to the voltage of the apparatus.

EXTEND CONCEPT GMC 4 OPEN BURNERS

4.2. Connecting the appliance

Electric ignition

Unscrew the front control panel to access the connection box, (see § “Gas connection”, Fig. A).
Thread cable through the terminal box (fixed with 2 screws).
Connect cable to the terminals, and follow the information written on the terminal box.
Before reassembling the parts, check the electrical equipment is properly insulated (cable).

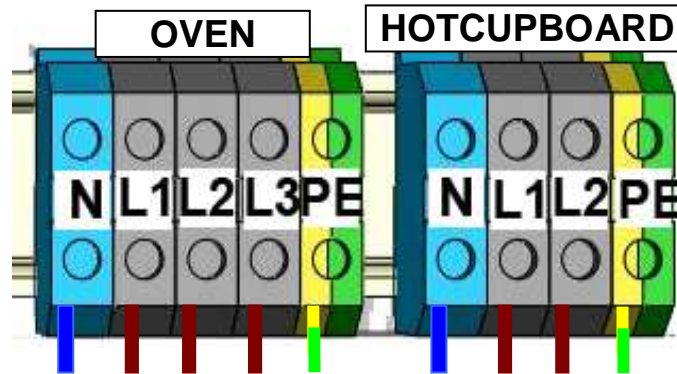

4.3. Checks after connection

- The appliance is earth wired,
- All electric parts are well isolated,
- The appliance is in good working order (ignition, thermostat, etc.).

STARTING UP: Please see the user's manual, section “Starting up”

4.4. Adapting the appliance to the various electrical supplies voltage

<i>Voltages available</i>				
<i>Voltage of appliance</i>		1~230V + E	3~230V + E	3~400V + E
	Wiring diagrams #	S = standard coupling		
Hot cupboard	TR0038	S	A	A
Electric ignition	TR0087	S	A	A
Electric oven	TR0101	S	A	A
A → Coupling possible B → Please consult the factory C → Coupling impossible D → No voltage available				

5. CONNECTING THE WATER TANK

5.1. Checks before connection

- Purge the supply water pipe and clean the filter,
- Check that both siphon and waste pipe are free of obstructions.

5.2. Connecting the appliance to the water supply system

Remove the control panel (see "Gas connection" Fig. A),
Connect the water supply pipe to the connection 15/21 of the water tap.

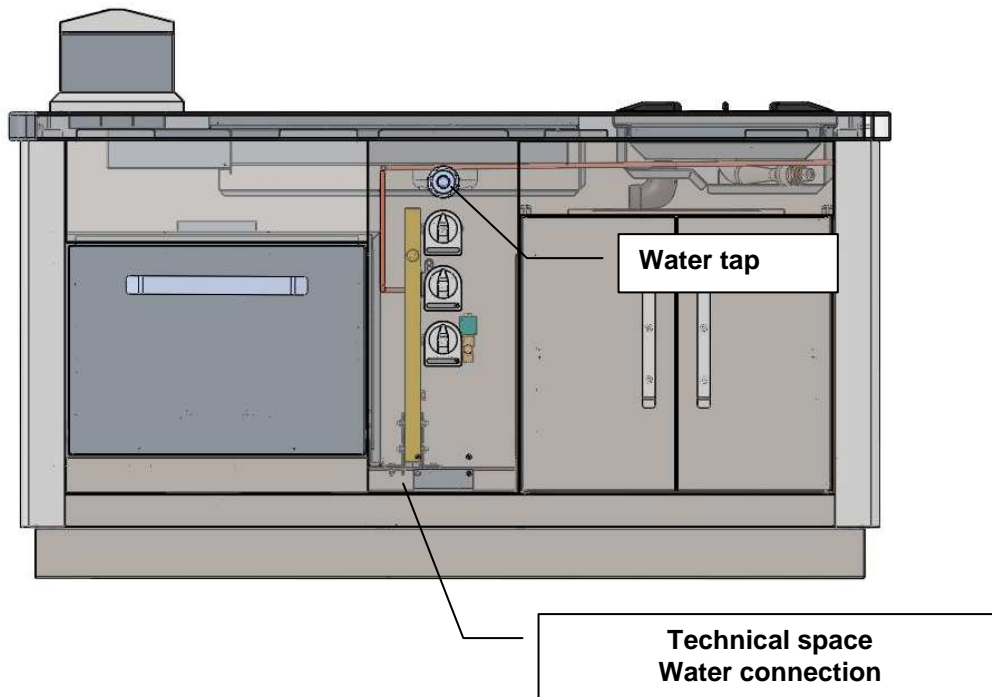

5.3. Checks after connection

After connection, ensure that:

- The water circuit is well watertight,
- The water circuit is in good working state,

Set the water flow to obtain a regular and low flow when the water tap is fully opened. This can be done by reducing the flow at the water connection of the appliance.

EXTEND CONCEPT GMC 4 OPEN BURNERS

6. WIRING DIAGRAMS

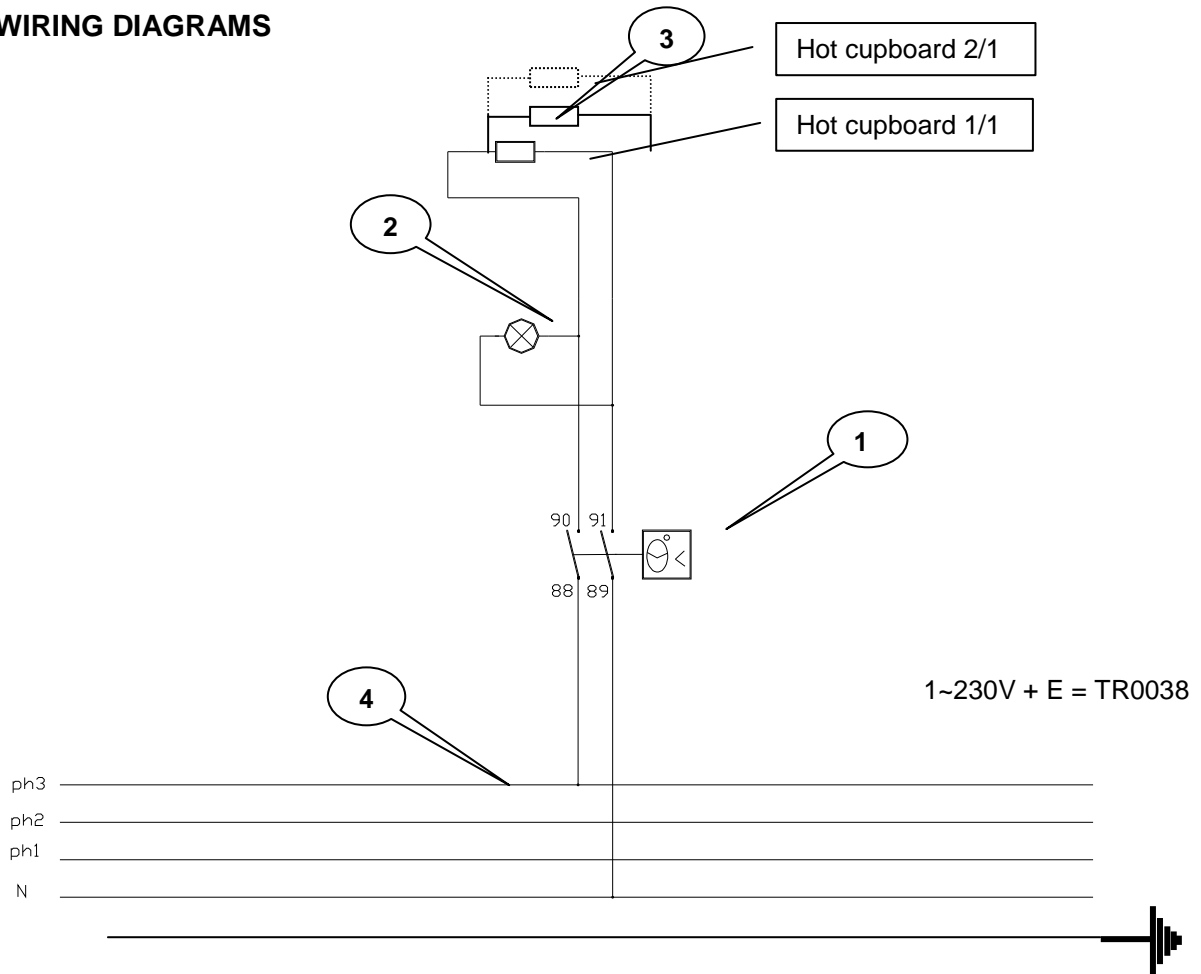

Nomenclature: Hot cupboard – single phase 230 V

Marks	Code	Description	Quantity
01	ELE0304	Regulation thermostat	1
02	ELE0434	230V heating indicator	1
03	ELE0231	Heating element 230V 600W	2
04	02466A	Terminal	3
04	03575A	Earth terminal Vicking	1

EXTEND CONCEPT GMC 4 OPEN BURNERS

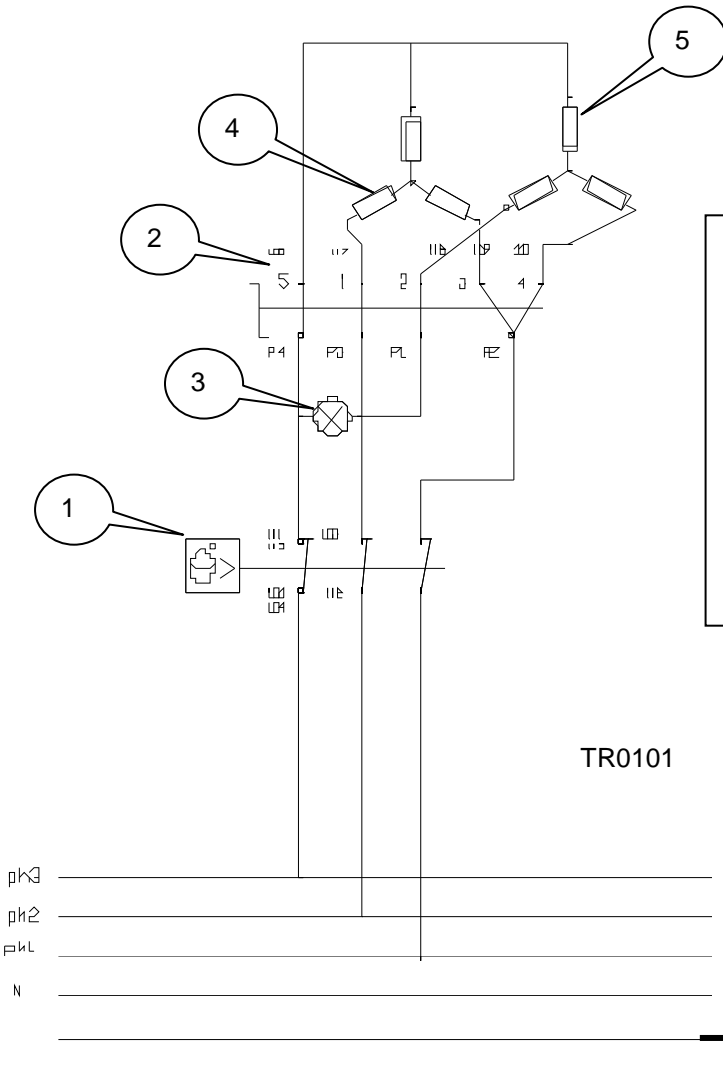

WIRING DIAGRAM

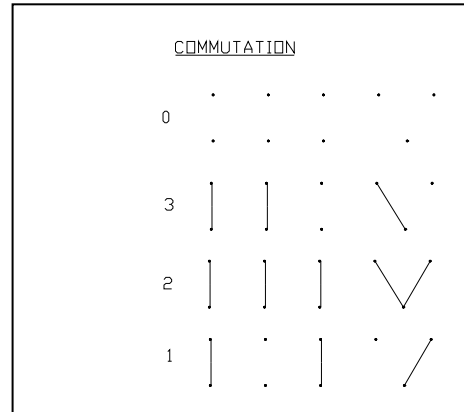

TR0101

Wiring diagram valid for switches having a rod with meplat up (set at 0).

For switches having a rod with meplat down below (set at 0), reverse:

- 107 and 108
- 109 and 110

Nomenclature: Electric pass-through oven

Marks	Code	Description	Quantity
01	08426A	Thermostat 350°C	1
02	Ele0074	4-position switch	1
03	Ele0435	400V heating indicator	1
04	502632	Vault heating element 1200W	3
05	502637	Mild steel base heating element 1800W	3

EXTEND CONCEPT GMC 4 OPEN BURNERS

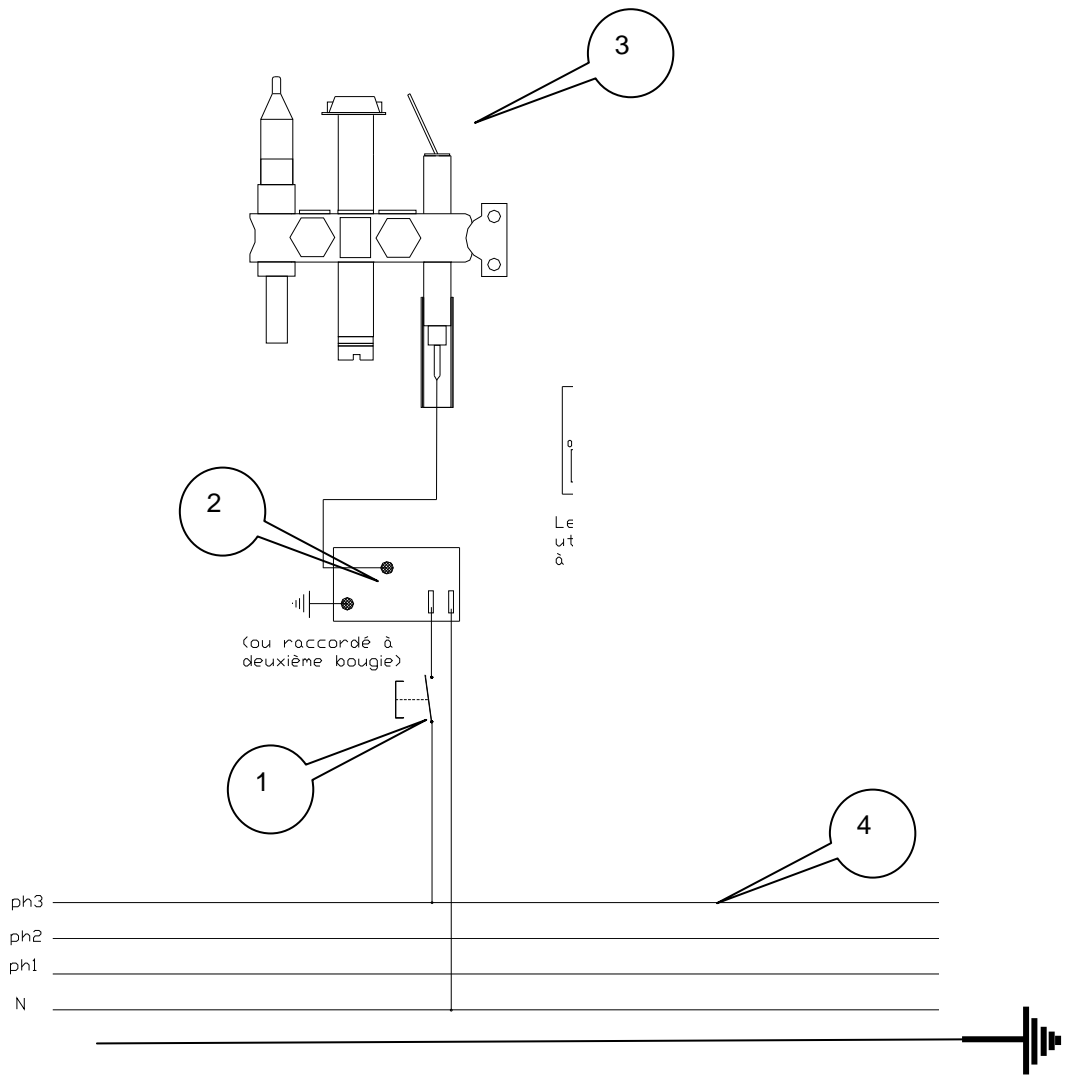

Nomenclature: Electric ignition of the burners TR0087

Marks	Code	Description	Quantity
01	ELE0018	Electric ignition push button	1
02	GAZ0002	2-point or 4-point igniter	1
03	07010A	Spark plug	1
04	02466A	Terminal	3
04	03575A	Earth terminal Vicking	1

EXTEND CONCEPT GMC 4 OPEN BURNERS

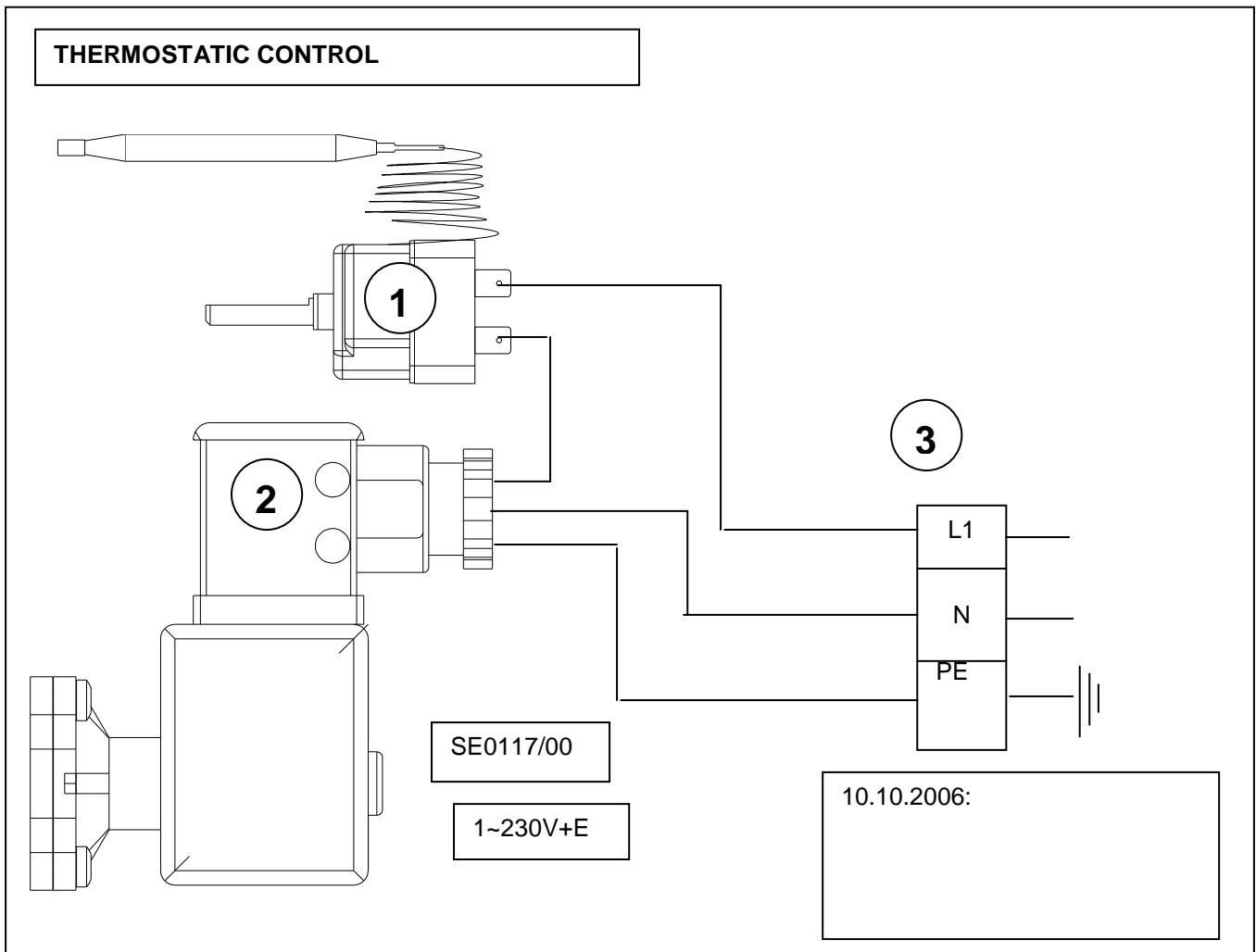

NOMENCLATURE: THERMOSTATIC CONTROL (SE0117/00)







Mark	Code	Description	Quantity
01	08426A	Thermostat	1
02	08425A	Solenoid valve	1
03	02468A	Terminal	1

EXTEND CONCEPT GMC 4 OPEN BURNERS

7. BASIC SPARE PARTS LIST

Description / Code	Photograph	Description / Code	Photograph
Gas tap 08094A		Thermostatic control 080425A	
Gas injector Open burners G20/G25 Ø 2.30 Natural 06984A G31 Ø 1.35 Propane 07146A		Gas injector Oven G20/G25 Ø 2.50 Natural 00209A G31 Ø 1.70 Propane 06250A	
Pilot light injector Open burners G30,G31 Ø 0.20 propane 06988A G20/G25 06989A Ø 0.35 natural		3-flame pilot light 07551A	
Thermocouple L = 00290A mm		Pilot light injector Oven G30,G31 Ø 0.20 Propane 06988A G20/G25 00559A Ø 0.40 natural	
Burner FN8KW 08067A burner cap 07822A Flame ring 08098A Burner body 08097A Safety device			

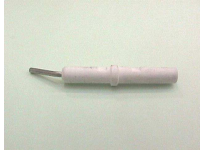
EXTEND CONCEPT GMC 4 OPEN BURNERS

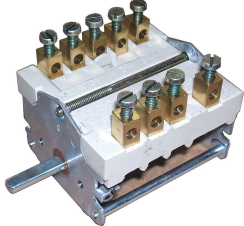
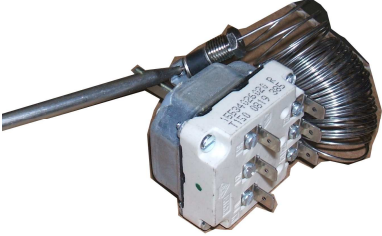
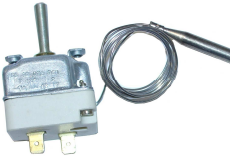
Description / Code	Photograph	Description / Code	Photograph
Orange indicator Ele0434 Red indicator Ele0435		Push button for ignition 08865A	
thermostatic control coil 08936A		4-point igniter 230V GAZ0002	
Electric oven heating element mild steel base 1200W 502632 Vault 1800W 502637		Electrode 07010A	
Hot cupboard heating element 230V ELE0231		Oven switch Ele0074	
Hot cupboard thermostat ELE0304			
Oven thermostat 350°C 08426A			

8. MAINTENANCE

8.1. Electric oven: changing the heating element

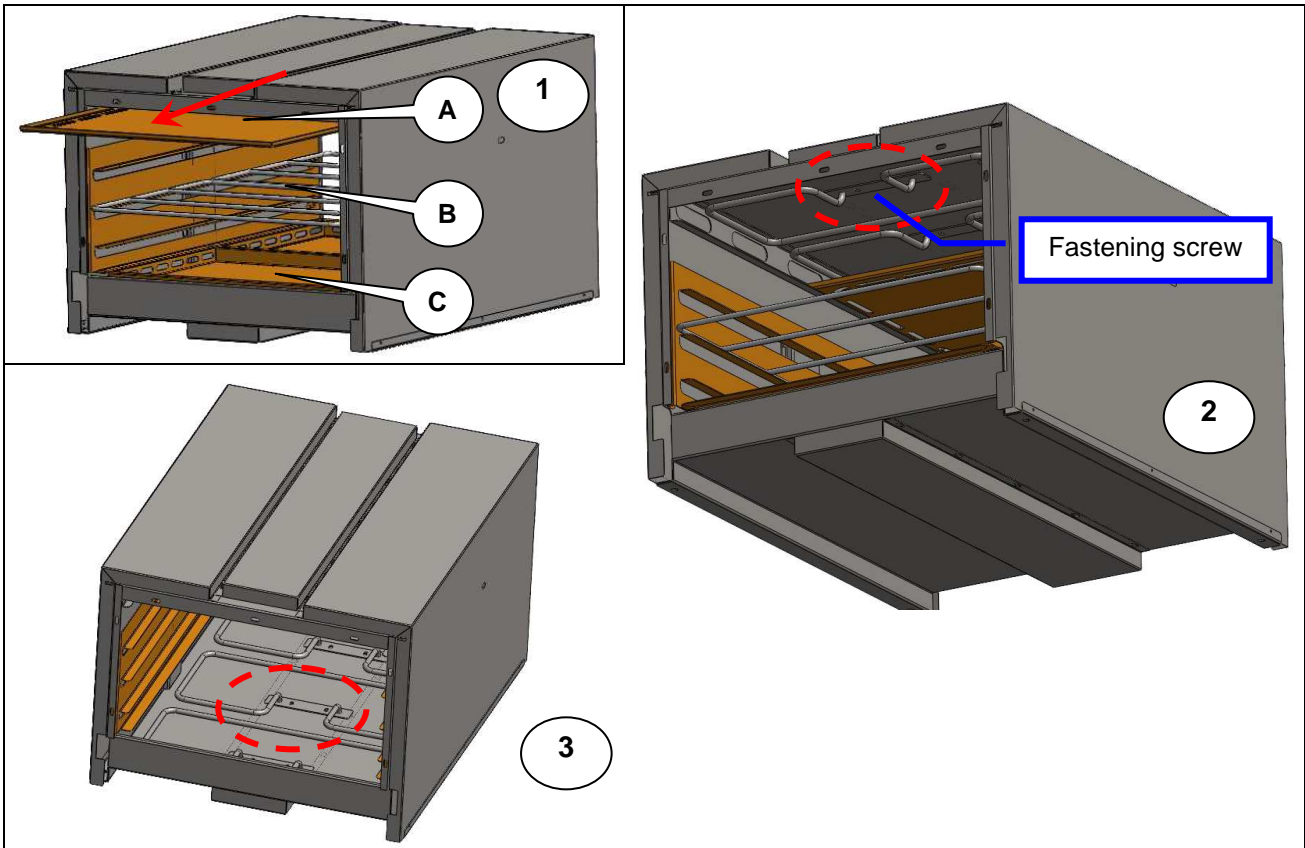

Removing the heating element :

Open the oven door. Remove the enameled vaults from the oven (A), the oven shelves (B) and the mild steel bases (C).

Unscrew the fixing screws (2) and (3) of the heating element, vault and mild steel base.

8.2. Hot cupboard : changing the heating element

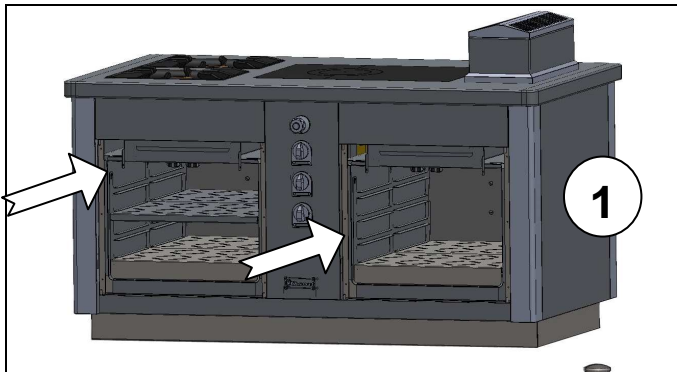
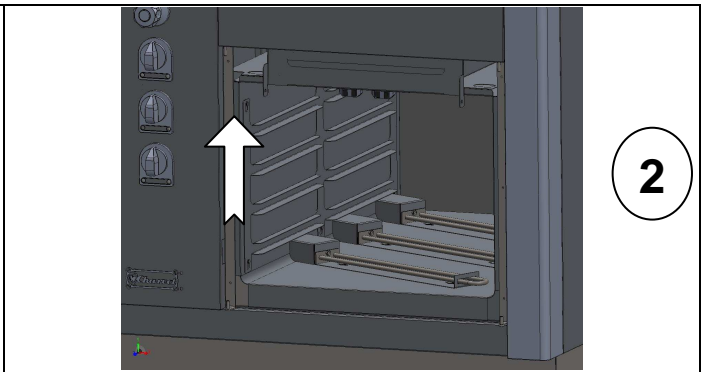
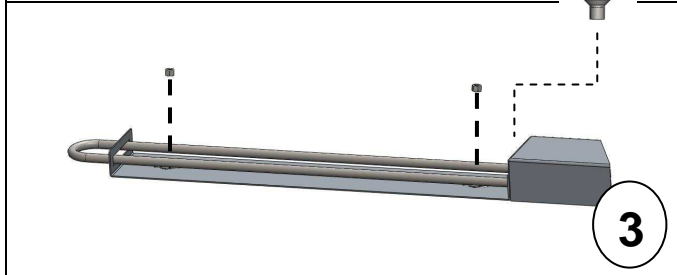
 <p>1</p>	 <p>2</p>
 <p>3</p>	<p>Removing the heating element:</p> <p>Remove the shelves. You can access the heating elements. Unscrew the nuts and screw. Remove the heating element. See § 7 "Basic spare parts list" for the reference.</p>

8.3. Changing the solenoid valve

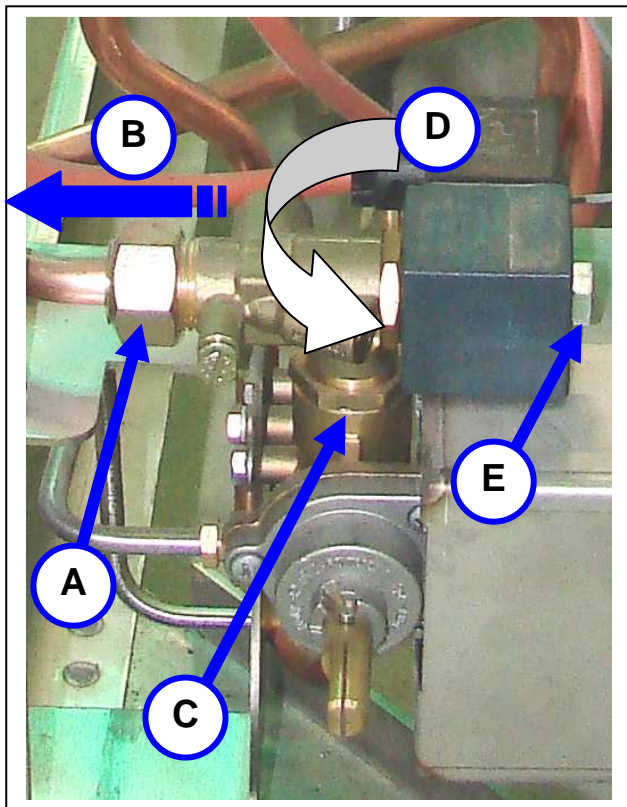

- **Changing the solenoid valve**

(A) Unscrew the nut and pull the copper pipe (B) to the left very carefully. Unscrew the nut (C), swivel (D) and unscrew the nut (E) to remove the solenoid valve.

GMC MODULE UNIT

Description	EXTEND CONCEPT
GMC0030	Module 1300
GMC0033	
GMC0156	



USER'S INSTRUCTIONS

CHARVET

F-38850 – CHARAVINES

Tel.: (33)-4-76-06-64-22

Fax: (33)-4-76-55-78-75

Email: info@charvet.fr

Email: sav@charvet-sa.fr



MANUAL: EN GMC 1300 4xOPEN BURNERS

Ind. A; Created on: 15/05/2009

Updated on:

SUMMARY

1. INTRODUCTION.....	3
2. PRIOR TO STARTING UP.....	3
3. STARTING UP.....	3
3.1. OPEN BURNERS	3
3.2. GAS OVEN	4
3.3. ELECTRIC OVEN	4
3.4. ELECTRIC HOT CUPBOARD.....	5
3.5. USE OF THE WATER TANK INSTALLED WITH OPEN BURNERS.....	5
4. SWITCHING OFF.....	6
5. MAINTENANCE.....	6
5.1. CLEANING THE STAINLESS STEEL SURFACES	6
5.2. CLEANING THE OVEN.....	6
5.3. MAINTENANCE OF THE MILD STEEL BASE, OVEN SHELF AND SHELF RUNNERS (IN A GAS OVEN)7	
5.4. MAINTENANCE OF THE MILD STEEL BASE, OVEN SHELF AND SHELF RUNNERS (IN AN ELECTRIC OVEN)	8
5.5. ELECTRIC HOT CUPBOARD.....	8
6. POSSIBLE CAUSES OF BREAKDOWN.....	9

1. INTRODUCTION

- A) Our equipment is for professional use only and must be used by qualified staff.
- B) The equipment must be installed in compliance with local codes and bylaws. It must be installed in a kitchen equipped with an adequately sized mechanical extraction system.
- C) Appliances may be installed side by side or against walls of non combustible material. Distance to combustible material shall be no less than 10 cm.
- D) It is imperative to call for a qualified engineer for all new installations or modifications of existing equipment.
- E) **WARRANTY:** *The warranty is mentioned in our conditions of sale. Only a qualified engineer certifies the validity of the warranty. This warranty does not cover damage due to faulty installation, misuse or inadequate maintenance.*

2. PRIOR TO STARTING UP

- a) Prior to starting up, it is advisable to clean the appliance in order to eliminate all dust and impurities that have accumulated during storage.
- b) Remove all plastic protection that wraps the stainless steel panels.
- c) Make sure that all controls are in good working condition before turning the gas on.

We recommend ovens are run empty for 1 or 2 hours to avoid an unpleasant taste of new material in food.

3. STARTING UP

General points: *Each burner is equipped with a safety thermocouple and a pilot light.*

3.1. Open burners

Ignition setting

Push and turn control knob counter-clockwise to the ignition symbol.

Keep pushing thoroughly. At the same time, press the push button and wait for about 20 seconds before releasing it.

If the pilot light blows out, try again and keep pressing control knob a bit longer.

Full power setting

To ignite the burner, keep turning control knob counter-clockwise to the full power symbol.

Low output setting

Push control knob and turn counter-clockwise to the low output symbol (small flame).

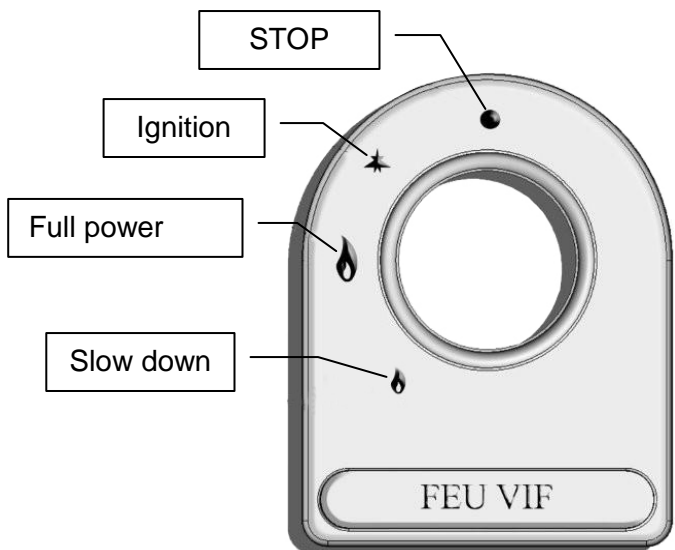

EXTEND CONCEPT GMC 4 OPEN BURNERS

3.2. Gas oven

- **Pilot light ignition**

Push and turn control knob counter-clockwise to the ignition symbol.

Keep pushing thoroughly. At the same time, press the push button and wait for about 20 seconds before releasing it.

If the pilot light blows out, try again and keep pressing control knob a bit longer. The pilot light can be seen through the hole in the mild steel base.

- **Temperature regulation device**

Press slightly the control knob. Turn it to position "8". The burner starts.

When done, choose the desired temperature.

N.B.: The temperature positions -from "1" to "8"- refer to temperatures comprised between 100°C and 350°C.

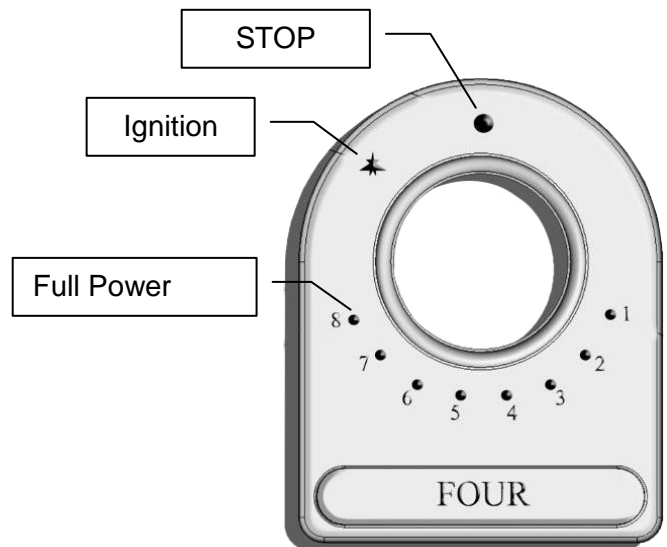

Oven racks enable different positions of shelves and trays according to the cooking time and type of foods. Nevertheless, be careful not to cook on 2 levels at the same time as it will block the burned gases route.

3.3. Electric oven

- Turn control knob to the desired position (vault/vault-mild steel base/mild steel base); the heating indicator is alight.

- Turn thermostat to the desired temperature; the heating indicator is illuminated.

- When the desired temperature is reached, the regulation indicator is darkened. The regulation thermostat will constantly adjust the temperature of the oven.

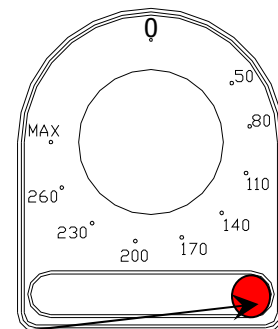
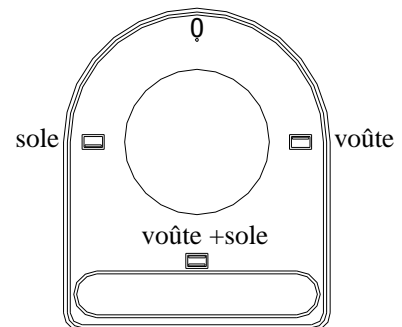

Read heating indicator

WARNING:

When opening the oven door in "wet" cooking mode, stay clear from the oven as vapours can escape and burn your skin very seriously!

Side panels and oven door may be extremely hot after a prolonged or intensive use. Be careful to open the door only with the handle.

3.4. **Electric hot cupboard**

The appliance is ON.
Turn the regulation thermostat knob to the desired temperature. The orange indicator remains illuminated until the desired temperature is reached.

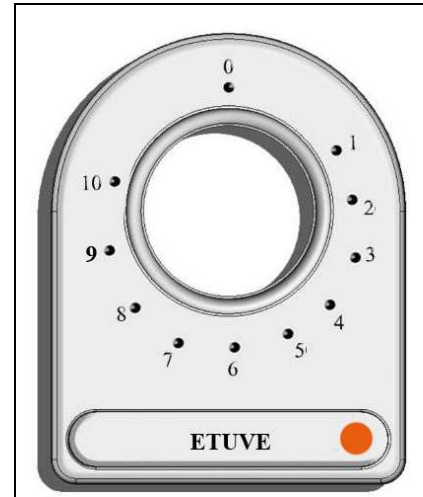

3.5. **Use of the water tank installed with open burners**

Fig. I

Sluce gate

Water Flushing

Water tank

Fig. J

Sluce gate

Water tank

OVERFLOW EXIT

- Before using the water tank, ensure the sluce gate is in correct position (fig. I) and (fig. J).
- Open the water tap (fig. L) and allow filling to level MAXI of the sluce-gate (Fig. K).

N.B. 1: Take off the overflow device to empty the water tank.

N.B. 2: While the water tank is in use, check the watertightness of the water connection circuit.

N.B. 3: It is important to refit the sluce gate in position after each cleaning of the water tank.

4. SWITCHING OFF

At the end of the day, cut off gas supply and switch off electricity at the mains.

5. MAINTENANCE

Before doing anything on the appliance, wait until cooking areas has cooled down.

5.1. Cleaning the stainless steel surfaces

- a) Turn off the apparatus. After each service and before each cleaning operation, we advise you to disconnect the appliance from the mains.
- b) Wash with a sponge in soapy water (or any other *neutral* cleaning product).
Do not use bleach or any other acidic product – even well diluted.

Warning: Dry the pan supports carefully to avoid rusting. Then clean with a greasy cloth.

Note: Put back all the parts in correct position (crowns, pan supports, sluice gate, etc.).

5.2. Cleaning the oven

To avoid fumes due to greases, stains and food particles, we recommend you to clean all the oven internal sides every day.

The mild steel base can be removed to be cleaned. The burner housing can be cleaned as well (see § 5.3).

The shelf runners can also be removed to be cleaned (see § 5.3).

Wash the oven with a sponge in soapy water (or any other *neutral* cleaning product).

After cleaning, rinse and dry all the parts carefully.

Refit in order all the parts.

This appliance must not be cleaned with mechanical water jets or be subject to a deluge of water under pressure. Check that the appliance is well disconnected at the mains.

5.3. Maintenance of the mild steel base, oven shelf and shelf runners (in a gas oven)

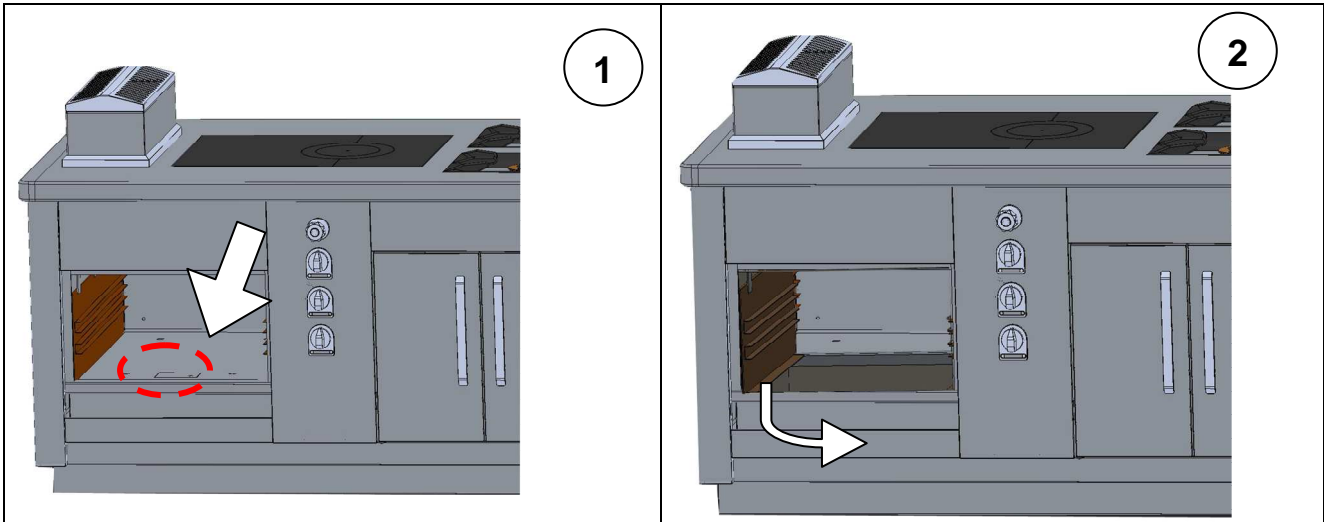

Process: disassembly and reassembly of mild steel base and shelf runners

Remove the oven shelf from the oven.

Remove the mild steel base using the oblong hole (fig. 1).

(fig. 2) Grab the shelf runner and pull it to the middle of the oven.

Then remove it from the oven.

The mild steel base is very heavy. Handle with care.

Weight: 23 Kg

5.4. Maintenance of the mild steel base, oven shelf and shelf runners (in an electric oven)

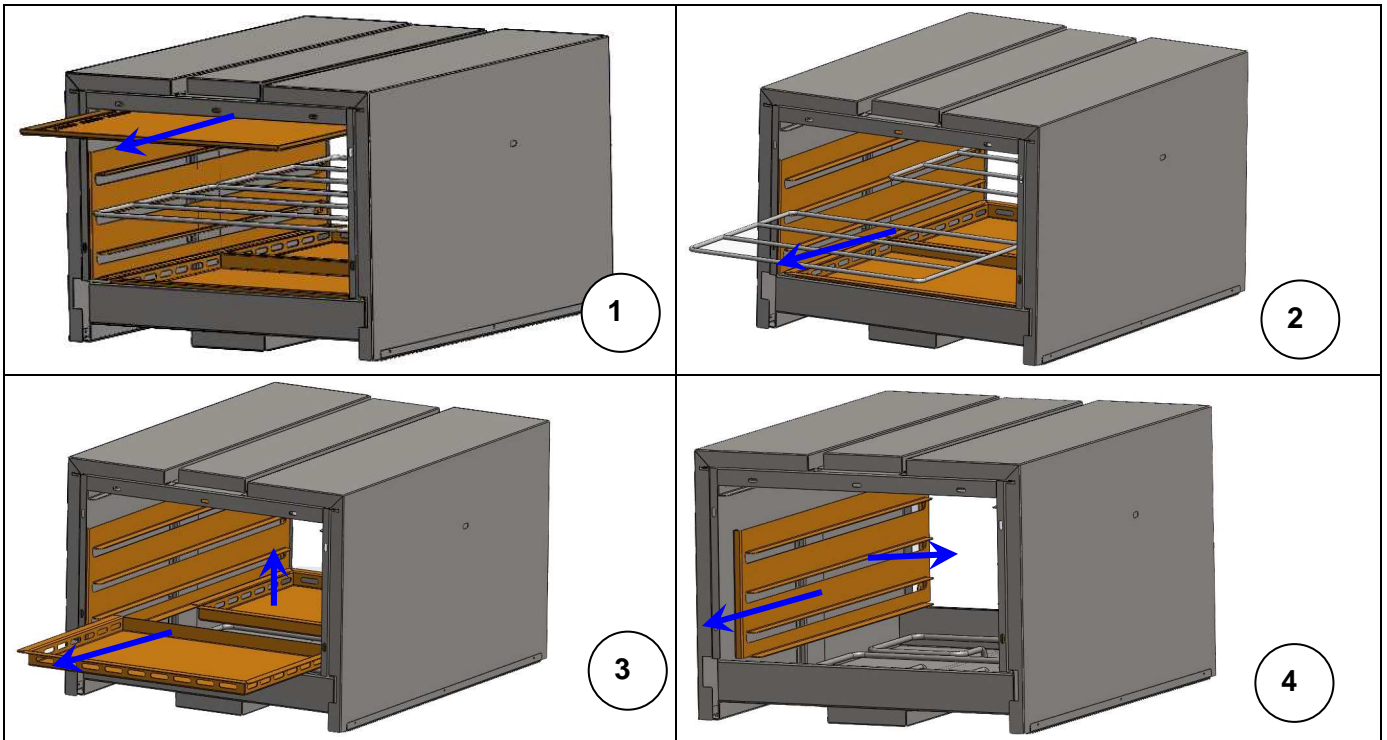

Cleaning the electric oven:

Open the oven door. Remove the enameled vaults from the oven (1), the oven shelves (2) and the mild steel bases (3).
 Remove as well the enameled shelf runners (4).
 Clean the parts in hot soapy water.

5.5. Electric hot cupboard

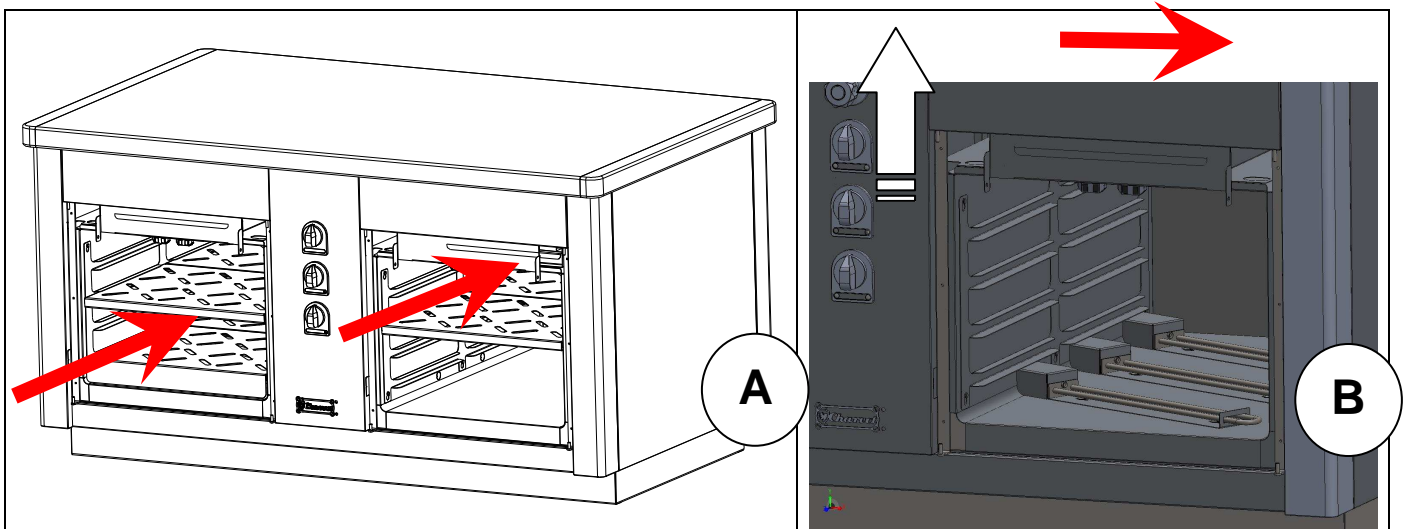

Cleaning operation:

Open the door and remove the removable shelves (A).
 Push them up before pulling them to the middle (B).
 Clean the parts in hot soapy water.

EXTEND CONCEPT GMC 4 OPEN BURNERS

For best results, have your equipment serviced and cleaned on a regular basis by a qualified installer.

WARNING: *Factory-sealed components must be serviced by neither installer nor user. Only a qualified electrician should replace the parts.*

6. POSSIBLE CAUSES OF BREAKDOWN



<u>Breakdown</u>	<u>Probable causes</u>
Unsatisfactory heating	Clogging of the burners, injectors, etc.
	Incorrect gas pressure.
	Incorrect grading of the injectors.
	Clogging of the rear internal flue box (oven).
Incorrect oven temperature	Faulty thermostat.
Incorrect ignition	Clogging of the pilot lights.
	Clogging of the thermocouples
	Faulty thermocouples, incorrect output of the pilot lights.
	Incorrect position of the pilot lights.
Faulty electric ignition	The control knobs are not pushed far enough.
	Incorrect position of the spark plug.

Call for your installer to replace the faulty electric components in preparation for a next use.



The manufacturer and the installer cannot be held responsible if the user neglects to ask for assistance in case of breakdown.

TRANSFER below information written on the data plate of your appliance.

	CHARVET S.A. 38850 CHARAVINES
Réf.	<input style="width: 100%;" type="text"/>
Code:	<input style="width: 50%;" type="text"/> Type: <input style="width: 50%;" type="text"/>
N°FC:	<input style="width: 50%;" type="text"/> <input style="width: 50%;" type="text"/>
N°OF:	<input style="width: 50%;" type="text"/> Rep. <input style="width: 50%;" type="text"/>
Cat.	<input style="width: 100%;" type="text"/>
Gaz	<input style="width: 100%;" type="text"/>
P (mbar)	<input style="width: 100%;" type="text"/>
ΣQ_n (kW)	<input style="width: 100%;" type="text"/>
ΣV_n (m ³ /h)	<input style="width: 100%;" type="text"/>
ΣM_n (kg/h)	<input style="width: 100%;" type="text"/>
U <input style="width: 50%;" type="text"/> V <input style="width: 50%;" type="text"/> Hz Ip <input style="width: 50%;" type="text"/>	
P <input style="width: 50%;" type="text"/> kW <input style="width: 50%;" type="text"/>	
	<input style="width: 100%;" type="text"/>
MADE IN FRANCE	

This will help you with maintenance problems and spare parts