

GMC 850 GAS CHROME/CAST IRON PLANCHA

DESCRIPTION	EXTEND CONCEPT
GMC0022	MODULE 850
GMC0081	
GMC0054	
GMC0089	



Installer's Instructions

CHARVET Paul s.a.

F-38850 – CHARAVINES
Tel.: +33 (0) 476 066 422
Fax: +33 (0) 476 557 875
Email: info@charvet.fr
Email: sav@charvet-sa.fr



MANUAL: GMC 850 GAS CHR/CAST IRON PLANCHA
ind. A; Created on: 24/09/2009
Updated on:

SUMMARY

1. INSTALLATION.....	3
1.1. GENERAL POINTS	3
1.2. HANDLING	3
1.3. INSTALLATION	3
1.4. DATA PLATE.....	4
2. GAS CONNECTIONS.....	4
2.1. CHECKS BEFORE CONNECTION.....	4
2.2. CONNECTING THE APPLIANCE TO THE GAS MAINS.....	5
2.3. CHECKS AFTER CONNECTION	5
2.4. CHECKS OF PRESSURE SUPPLY	6
3. CONVERSION TO OTHER TYPES OF GAS	6
3.1. CHANGING THE INJECTORS AND ADJUSTING THE AIR	6
3.2. CHANGING THE INJECTORS AND ADJUSTING THE PILOT LIGHT AIR OF THE OVEN AND PLANCHA.....	7
3.3. GAS SETTING CHARTS	8
3.4. ADJUSTING THE LOW OUTPUT OF THE PLANCHA	9
4. POWER CONNECTION.....	10
4.1. CHECKS BEFORE CONNECTION.....	10
4.2. CONNECTING THE APPLIANCE TO THE ELECTRIC NETWORK.....	10
4.3. CHECKS AFTER CONNECTION	11
4.4. ADAPTING THE APPLIANCE TO THE VARIOUS ELECTRICAL SUPPLY VOLTAGES.....	11
5. CONNECTING THE WATER FLUSHING.....	11
5.1. CHECKS BEFORE CONNECTION.....	11
5.2. CONNECTING THE APPLIANCE TO THE WATER MAINS.....	11
5.3. CHECKS AFTER CONNECTION	11
6. WIRING DIAGRAMS	12
7. BASIC SPARE PARTS LIST.....	16
8. MAINTENANCE.....	17
8.1. ELECTRIC OVEN: CHANGING THE HEATING ELEMENT	17
8.2. HOT CUPBOARD: CHANGING THE HEATING ELEMENT.....	17
8.3. CHANGING THE SOLENOID VALVE	18
9. EXPLODED VIEW OF A PLANCHA	19

1. INSTALLATION

1.1. General points

Installation must be undertaken in compliance with the following instructions and with local codes and bylaws. Ensure you have a suitable and sufficient risk assessment in place.
This appliance is of A-type and shall not be connected to a flue gas pipe.

The user's manual must be given to the user after installation.

1.2. Handling

It is imperative to leave the appliance on its wooden pallet for handling on site until the final installation. Unpack and check the appliance for damage upon receipt.

In case of damage, mark delivery note accordingly and immediately (within 48 hours) notify the carrier by registered mail with acknowledgement of receipt. Notify your seller.

1.3. Installation

All local fire regulations must be adhered to.

- The appliance must be installed under a suitable mechanical extraction hood.
- If the apparatus is to be installed against a wall or partition, near a piece of furniture or decorative borders, it is recommended that these are made of fireproof material.
- If this is not the case, they must be protected by an approved fireproof, insulating material.
- If in doubt of fireproof construction of adjacent walls, distance to combustible material shall be no less than 10 cm.
- Remove all plastic protection.
- Install the appliance in the kitchen.

Warning



Fixed appliance:

- Check that the masonry plinth is well horizontally leveled.
- Adjust height to level the unit to a horizontal working plan of 900 mm.
- Remove the plinth (fixed with 2 screws) – see Gas Connections § 2.2 – Fig. B (5).

**Any technical action on an appliance must be undertaken by a qualified technician.
The appliance will have to be isolated from the electrical supply for the duration of the work.**

When the appliance is ready for use, ensure the users know how to use it properly.
(Please see the user's manual).

Warranty: This warranty does not cover damage due to faulty installation, misuse or inadequate maintenance.

1.4. Data plate

Each appliance has its own data plate. Transfer all the information written on the data plate to the part of the user's manual reserved for it.

This will ease the communication between you and your client for better service.

	
<p>The data plate is on the cupboard door (GMC0081 and GMC0089)</p>	<p>Appliance with oven: data plate in front (GMC0022 and GMC0054)</p>

2. GAS CONNECTIONS

Warnings



• **Fixed appliance:**
Connect the appliance to the gas mains using 1/2" NPT pipe and connections. Install a suitable shutoff valve (or valve + pressure regulator) in the supply line, allowing the unit to be isolated from the rest of the cooking range.

• **Mobile appliance:**
Connect a 1/2 NPT approved armoured flexible gas hose equipped with a quick disconnect fitting including automatic gas shutoff valve to the gas connection located on the rear of the appliance. *Remember to use the security chain.*

2.1. Checks before connection

- Ensure that the supply pressure and the nature of gas match that shown on the data plate of the appliance.
- The mains should be free of obstructions, and clean.
- Ensure that the gas supply pipe is of the correct size for minimum pressure drop as a function of length, elbows and total unit capacity.
- It is required a fresh air input of 31m³/h/kW (see chart below).
- The type of gas used: Ensure that the appliance is set for the type of gas supplied (nature/pressure); see data plate on the appliance and label on the gas connection.

CHART			
Code	Appliance	Power (kW)	Fresh air input required (m ³ /h/kW)
GMC0022	MODULE 1300	15.5 kW	31 kW
GMC0054	MODULE 1300	15.5 kW	31 kW
GMC0081	MODULE 1300	15.5 kW	31 kW
GMC0089	MODULE 1300	15.5 kW	31 kW

2.2. Connecting the appliance to the gas mains

- Remove the control knobs (fixed with 2 screws), then remove the water tap (1),
 - Unscrew (3) and pull the bottom of the panel up and out.
 - Connect to connection 20/27 (4) located in the technical space.
- Note: the technical space is behind the control panel.*

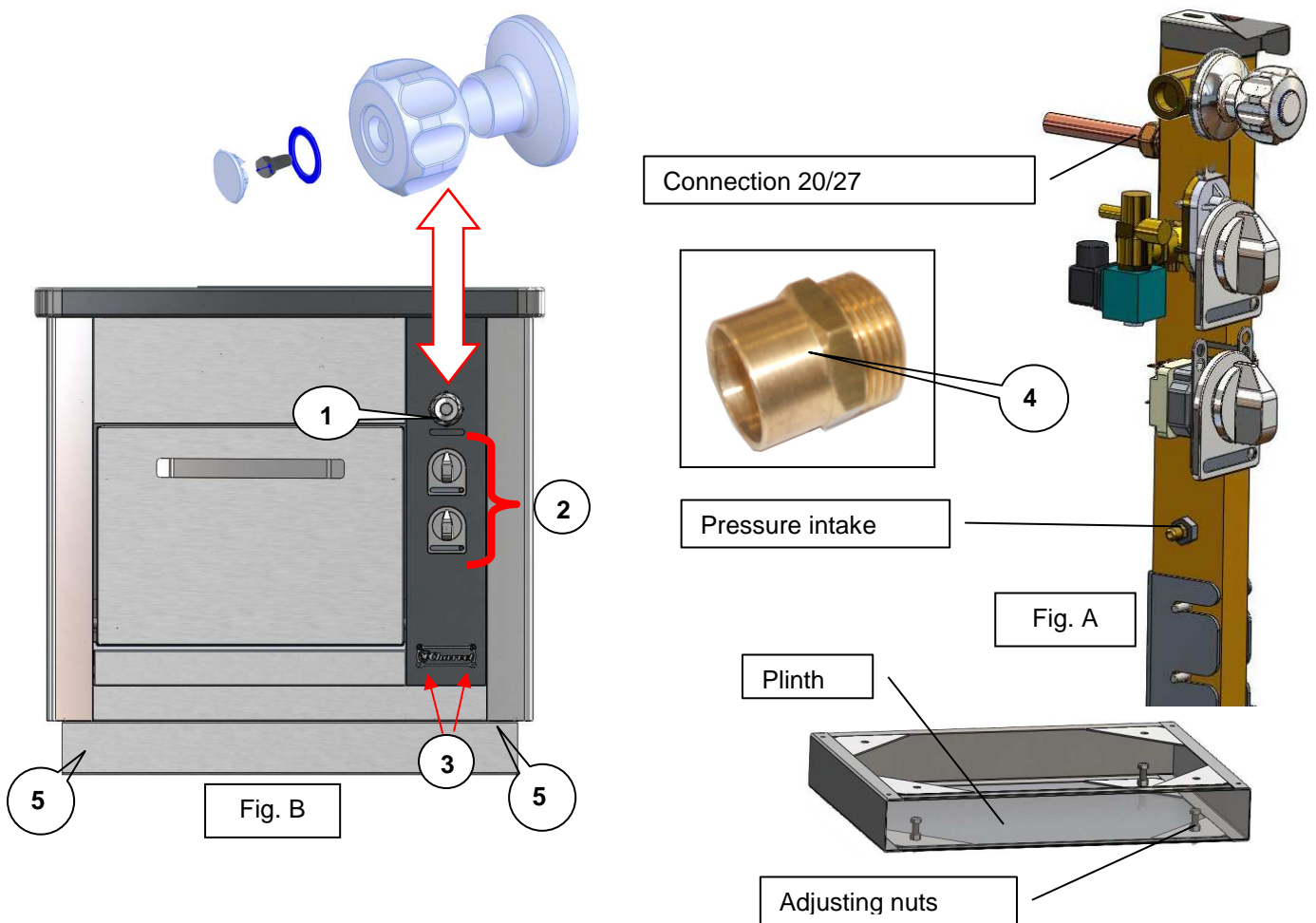

2.3. Checks after connection

- Watertightness of the gas pipe,
- Supply pressure of the appliance in working state,
- The colour of the flame (blue),
- The slow-down position (see § 3.4.),
- The good working state of the appliance and its safety devices.

2.4. Checks of pressure supply

Taking the pressure:

- Remove the control knobs,
- Remove the control panel,
- Connect the manometer on the pressure tap located on the burner ramp,
- Switch ON appliance to maximum setting,
- Then check your figures (see § 3 “Gas Adjustments”).

Note: All the appliances connected to the same gas supply should be in working state while taking the pressure supply.

3. CONVERSION TO OTHER TYPES OF GAS

Change of gas upon installation: After having replaced the injectors, ensure of the watertightness of the connection between the injector and its support.

3.1. Changing the injectors and adjusting the air

See charts § 3.3. according to the type of burners.

- Choose the correct diameter depending on the nature of the gas,
- Get the right air adjustment for the air ring.

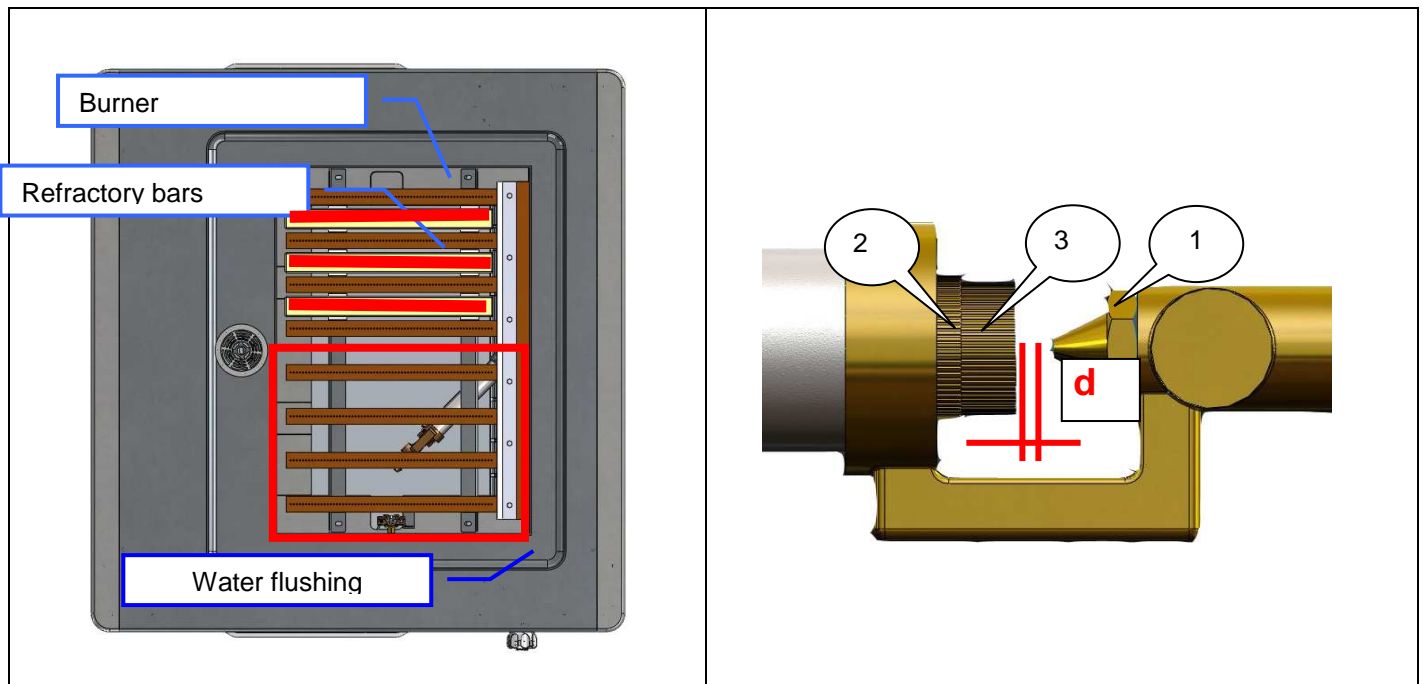

GMC 850: Chrome steel/cast iron plancha

- Remove the plate (2 persons are necessary to remove it), then the refractory bars, You have access to the burner and pilot light.
- Unlock the air ring (nut/ring – 2/3),
- Change the injector (1) with the help of a 12mm ring spanner,
- Adjust distance “d”,
- Lock the air ring (nut/ring),
- Then adjust and seal.

**Note: weight of a plate = 71.4 kg
For your safety, handle with care these parts.*

3.2. Changing the injectors and adjusting the pilot light air of the oven and plancha

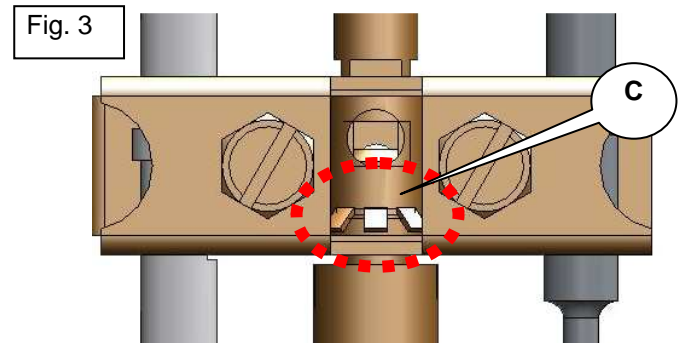
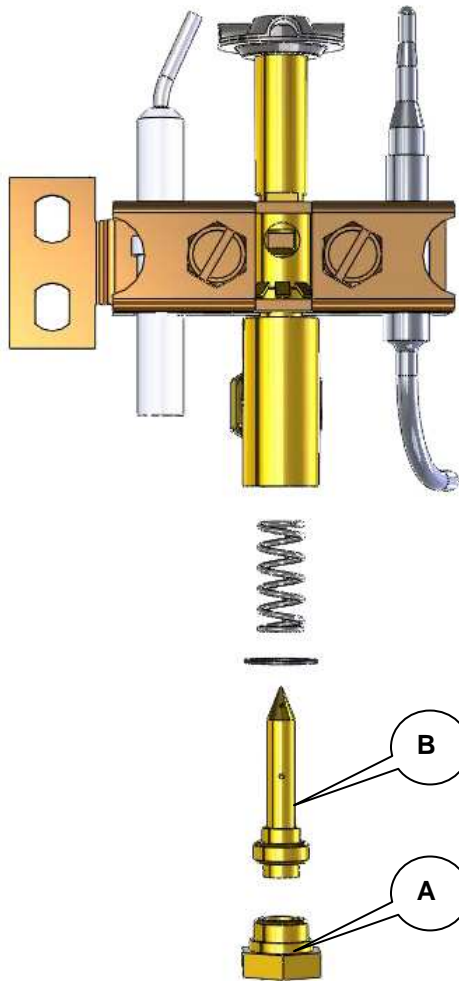

- Remove the mild steel base,
 - Unscrew the nut (A) with an open-end spanner 11mm,
 - Change the injector (B); see chart § 3.3.,
 - Adjusting the air ring (C): see chart § 3.3.,
- When the injector is changed, check the watertightness of the gas pipe and the good working condition of the pilot light.

3.3. Gas Setting Charts

Plancha		Plancha CHR/THE	Plancha CHR/THE	Cast iron plancha	Cast iron plancha
Adjustment	Gas type & operating pressure	Mark engraved on the injector	Air adjustment	Mark engraved on the injector	Air adjustment
1	G 20: Pn = 20 mbar	300	2	300	2
2	G 25: Pn = 20 mbar	320	2	320	2
3	G 25: Pn = 25 mbar	300	2	300	2
4	G 30: Pn = 29 mbar	200	Max	200	Max
5	G 30: Pn = 50 mbar	175	Max	175	Max
6	G 31: Pn = 37 mbar	200	Max	200	Max
7	G 31: Pn = 50 mbar	190	Max	190	Max

Pilot light				Plancha	Plancha
Adjustment	Gas type & operating pressure			Mark engraved on the injector	Air adjustment
1	G 20: Pn = 20 mbar			40	none
2	G 25: Pn = 20 mbar				
3	G 25: Pn = 25 mbar			20	none
4	G 30: Pn = 29 mbar				
5	G 30: Pn = 50 mbar				
6	G 31: Pn = 37 mbar				
7	G 31: Pn = 50 mbar				

3.4. Adjusting the low output of the plancha

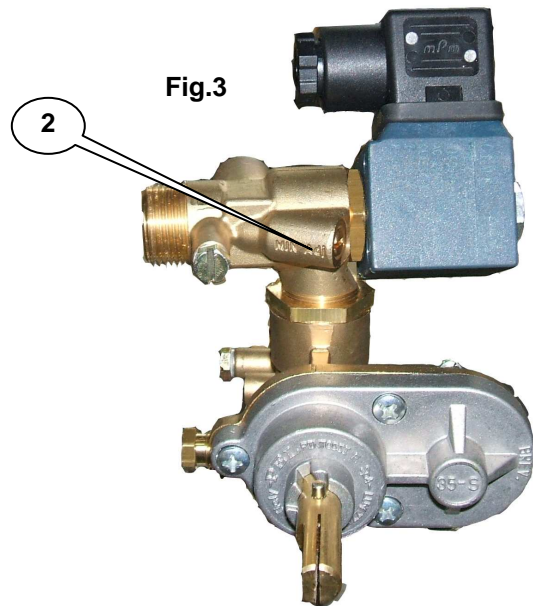

Positions	Temperatures (°C)
1	130°
2	160°
3	200°
4	230°
5	260°
6	290°
7	320°
8	350°

01	1 = lowest temperature
01	8 = highest temperature
02	Adjusting the output Only qualified staff can do the adjustment.

• Adjusting the oven output

- Remove the control knobs,
- Remove the control panel (see "Gas connection" § 2.2.).
- Refit the control knob and set to position 1, (= minimum cut temperature),
- Start the appliance up (see the user's manual),
- Wait until the thermostat cuts (the coil of the solenoid valve is not functioning) in order to maintain a minimum flame without extinguishing the burner,
- To increase the output, turn the screw counter clockwise.
- To lower the output, turn the screw clockwise (fig. 3).

When done, check the first sequences of regulation and make sure the flame still remains alight when the solenoid valve cuts.

4. POWER CONNECTION

Warnings



The appliance must be earth wired.
It is dangerous to connect the appliance unless it is earthed.
We cannot be held responsible for accidents due to
non existent or incorrect earth link connection.

Fixed appliance:

Check that the electric network is equipped with all-pole circuit breakers having a cross section of 3.5 mm at least. All electrical equipment must be in compliance with the standard EN 60335-1.

WARNING:

Use a standardized cable (245 IEC 57 or 245 IEC 66) or other approved cable with the same characteristics.

All these operations are carried out when the apparatus
is switched off, and cold.

4.1. Checks before connection

- The electrical voltage of the supply is compatible with the voltage of the apparatus (see data plate and § 5).
- The cable is fixed properly,
- The connections are tight enough,
- The section of the cable is of correct size according to the voltage of the apparatus.

4.2. Connecting the appliance to the electric network

Electric ignition

- Unscrew the front control panel to access the connection box (see the “gas connection” section, fig. A),
- Thread cable through the terminal box (fixed with 2 screws),
- Connect cable to the terminals according to the photographs below, and follow the information written on the terminal box.
- Before reassembling the parts, check the electrical equipment is properly insulated (cable).

Note: The ignition push buttons and indicators should remain in place.

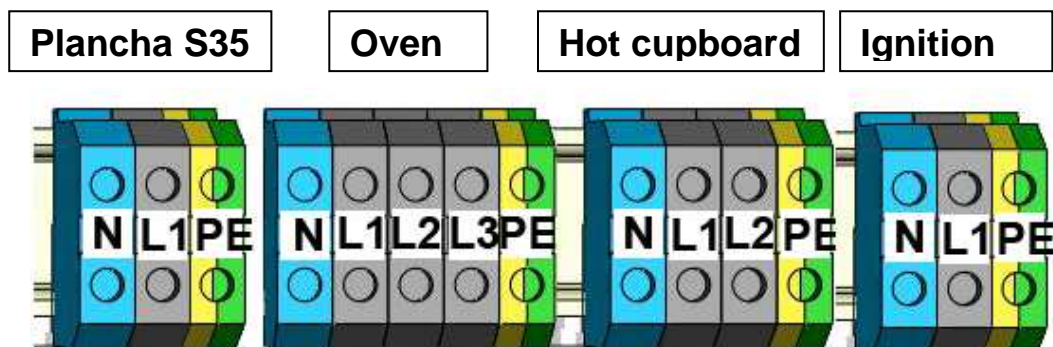

4.3. **Checks after connection**

- The appliance is earth wired (see the warnings),
- The electric equipment is well isolated from the rest of the equipment,
- The appliance is in good working order (ignition, thermostat, etc.).

STARTING UP: see the user's manual

4.4. **Adapting the appliance to the various electrical supply voltages**

<i>Voltages available</i>				
<i>Voltage of appliance</i>		1~230V + E	3~230V + E	3~400V + E
	Wiring diagrams #	S = standard coupling		
Hot cupboard	TR0038	S	A	A
Electric ignition	TR0087	S	A	A
A → Coupling possible B → Please consult Charvet C → Coupling impossible D → No voltage available				

5. **CONNECTING THE WATER FLUSHING**

5.1. **Checks before connection**

- Purge the supply water pipe and clean the filter,
- Check that both siphon and waste pipe are free of obstructions.

5.2. **Connecting the appliance to the water mains**

- Remove the control panel (see "Gas connection" fig. A),
- Connect the water supply pipe to the connection 15/21 of the water tap.

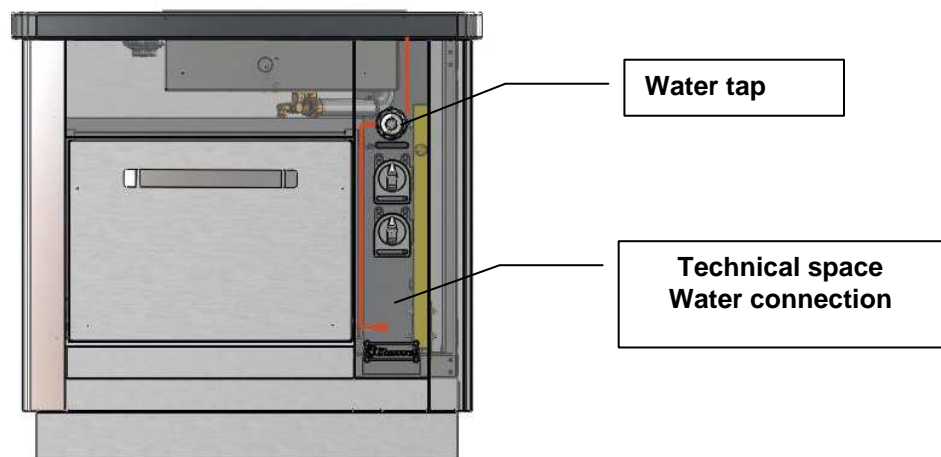

5.3. **Checks after connection**

- The water system is well watertight,
- The water circuit is in good working state,

Set the water flow to obtain a regular and low flow when the water tap is fully opened. This can be done by reducing the flow at the water connection of the appliance.

6. WIRING DIAGRAMS

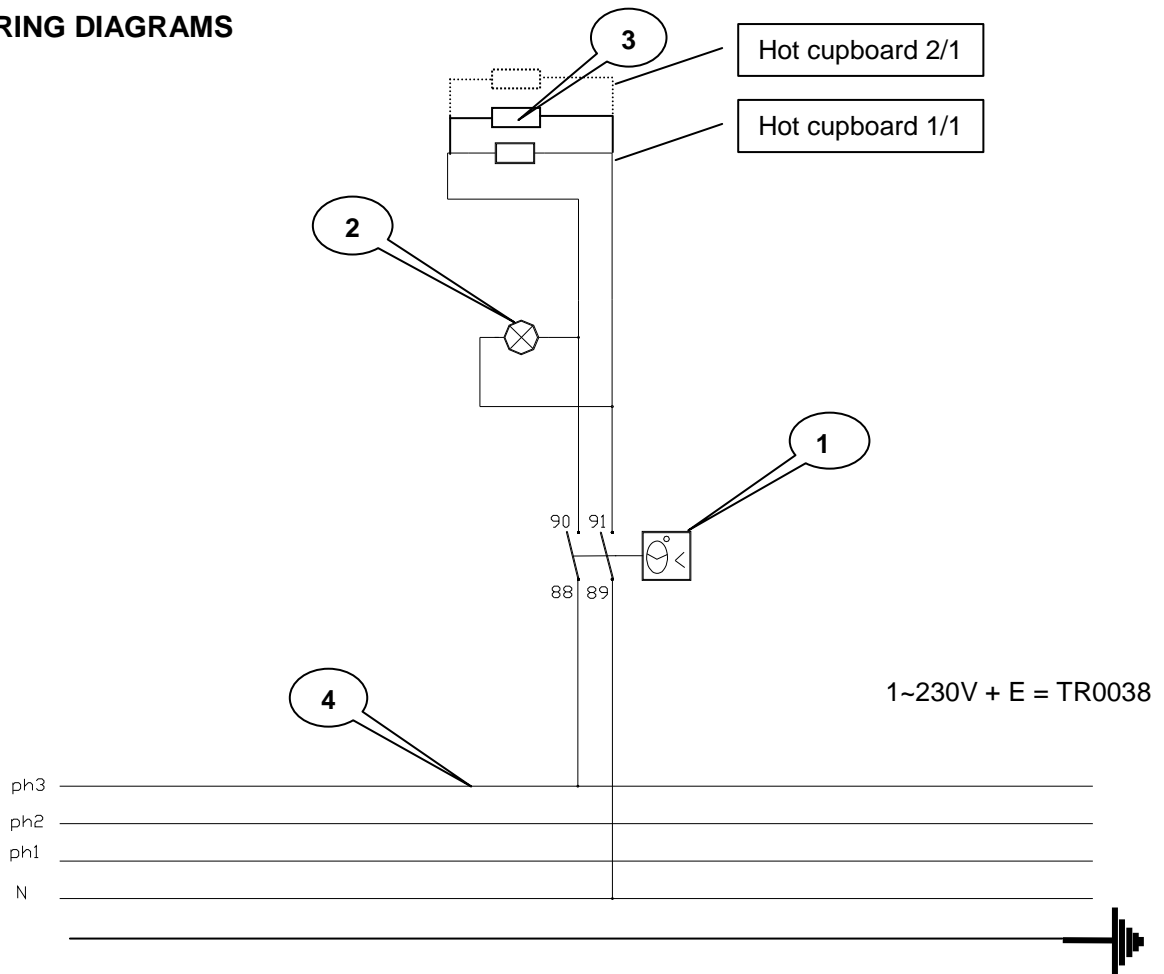

NOMENCLATURE: Hot cupboard – single phase 230 V

Mark	Code	Description	Quantity
01	ELE0304	Regulation thermostat	1
02	ELE0434	230V heating indicator	1
03	ELE0231	Heating element 230V 600W	2
04	02466A	Terminal	3
04	03575A	Viking earth terminal	1

GMC 850 GAS CHR/CAST IRON PLANCHA

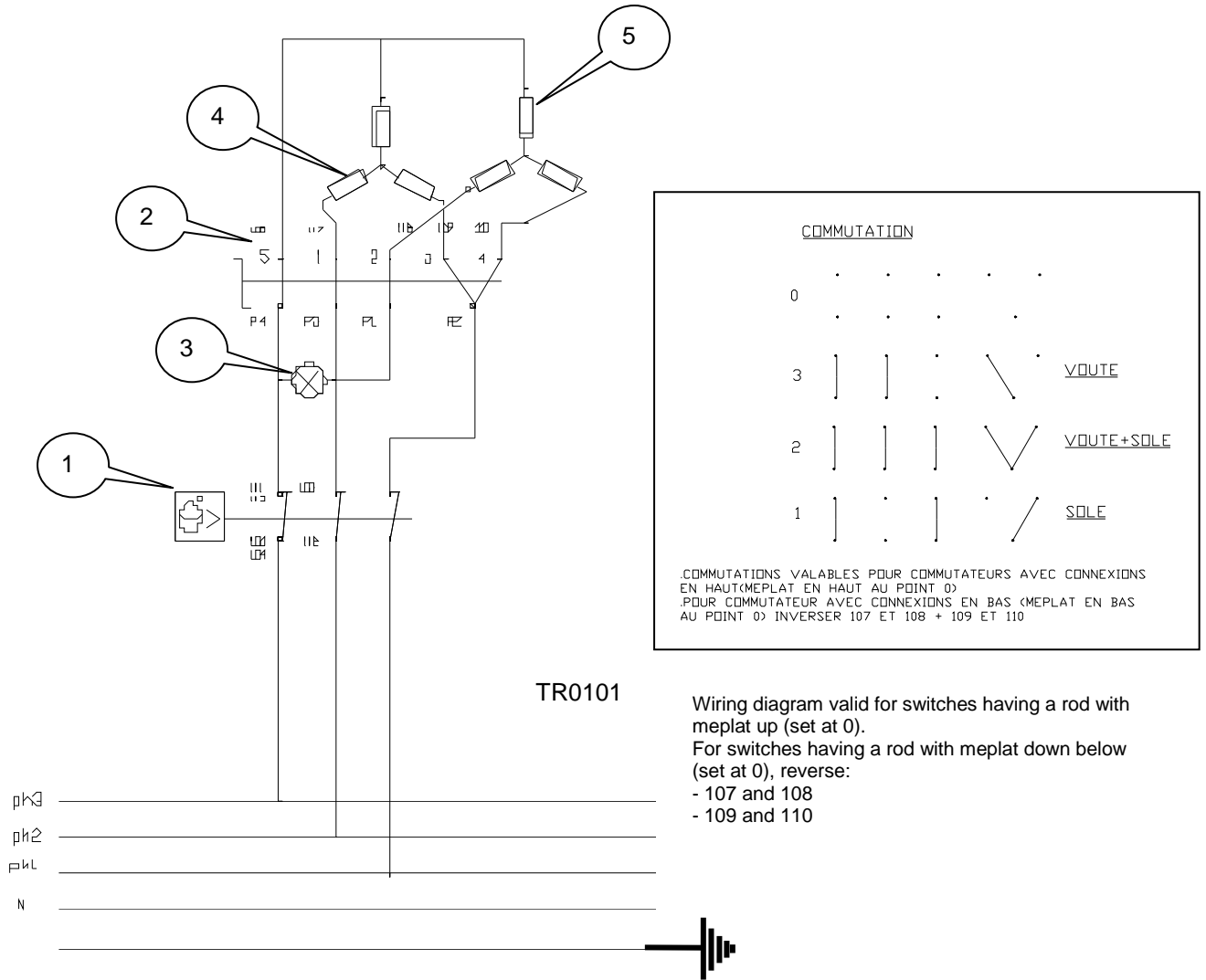

NOMENCLATURE: Electric pass-through oven

Mark	Code	Description	Quantity
01	08426A	Thermostat 350°C	1
02	Ele0074	4-position switch	1
03	Ele0435	400V heating indicator	1
04	502632	Vault heating element 1200W	3
05	502637	Mild steel base heating element 1800W	3

GMC 850 GAS CHR/CAST IRON PLANCHA

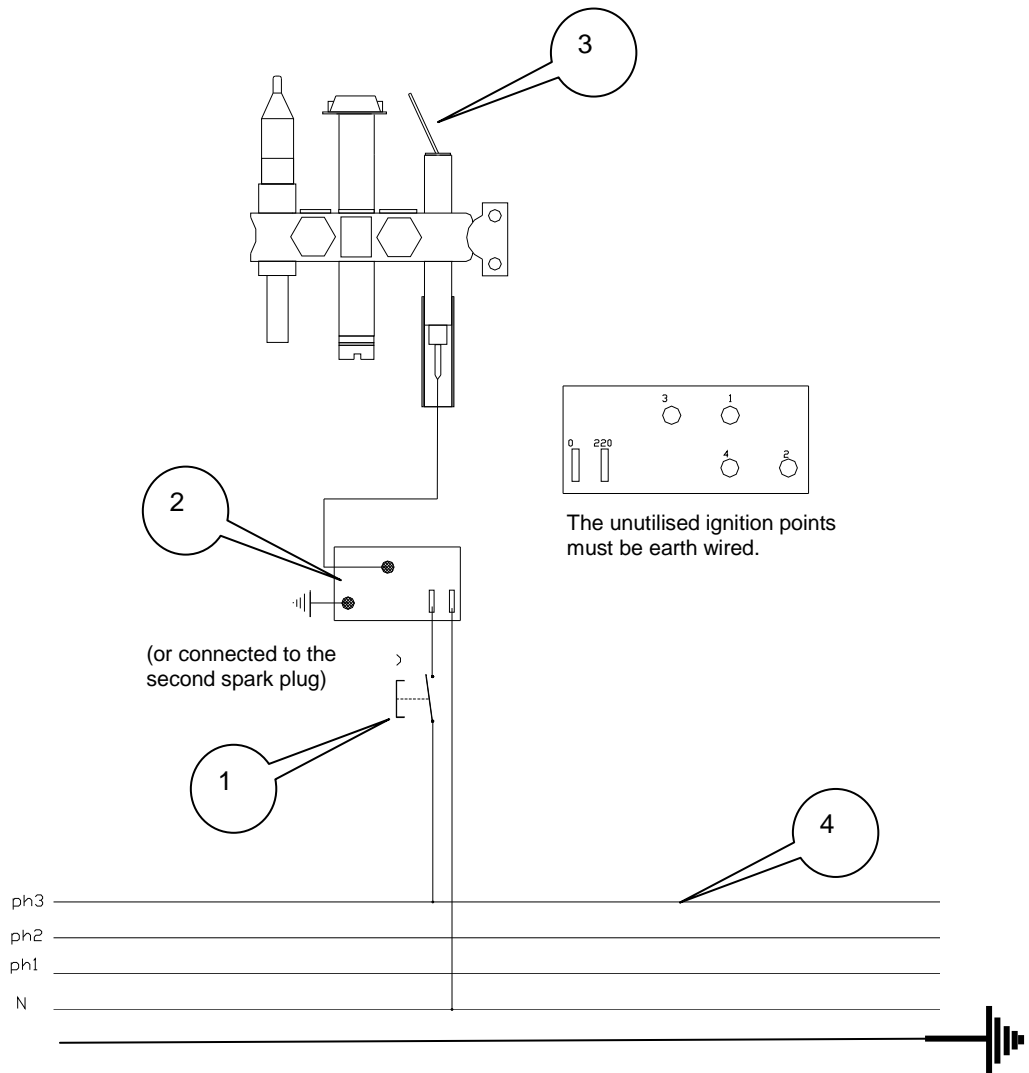

NOMENCLATURE: Electric ignition of the burners TR0087





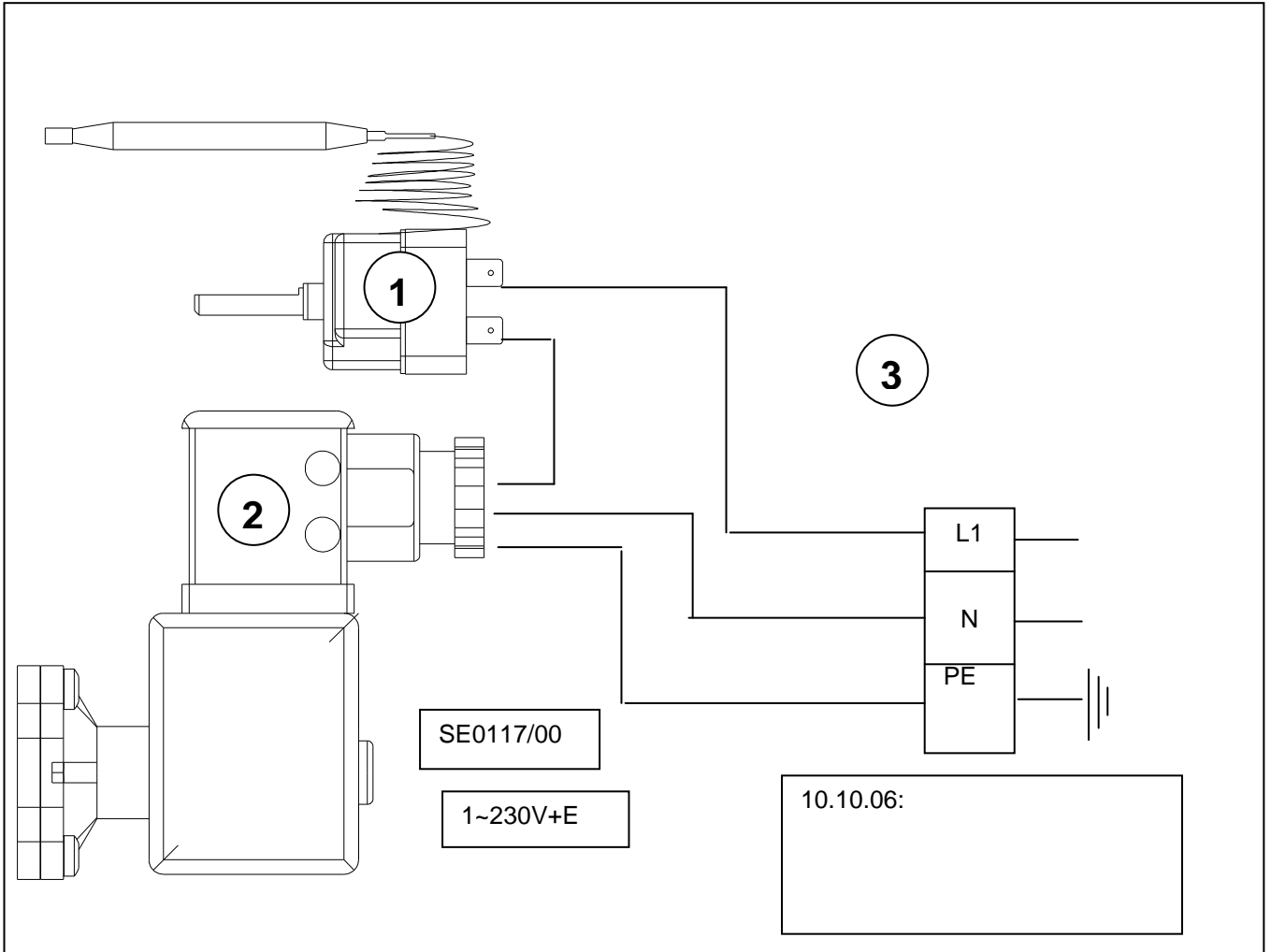







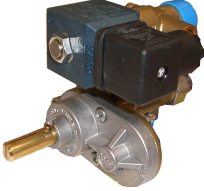

Mark	Code	Description	Quantity
01	ELE0018	Electric ignition push button	1
02	GAZ0002	2-point or 4-point ignitor	1
03	07010A	Spark plug	1
04	02466A	Terminal	3
04	03575A	Vicking earth terminal	1

GMC 850 GAS CHR/CAST IRON PLANCHA

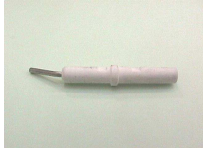

Mark	Code	Description	Quantity
01	08426A	Thermostat	1
02	08425A	Solenoid valve	1
03	02468A	Terminal	1

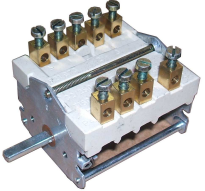
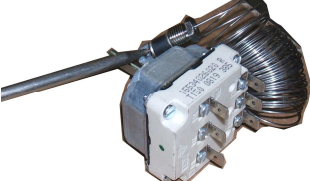
7. BASIC SPARE PARTS LIST

Description / Code	Photograph	Description / Code	Photograph
Gas injector oven G20/G25 Ø 2.50 natural 00209A G31 Ø 1.70 Propane 06250A		3-flame pilot light 07551A	
Gas injector plancha G20/G25 Ø 3.00 natural 00214A G31-50 Ø 1.90 propane 00203A		Pilot light injector oven G30-G31 Ø 0.20 Propane 06988A G20/G25 00559A Ø 0.40 natural	
Thermostatic control 080425A		Plate Chrome steel 08180A Cast iron 07458A	
Orange indicator Ele0434 Red indicator Ele0435		Push button for ignition 08865A	
thermostatic control coil 08936A		4-point ignitor 230V GAZ0002	
Electric oven heating element Mild steel base 1200W 502632 Vault 1800W 502637		Electrode 07010A	
Hot cupboard heating element 230V ELE0231		Oven switch Ele0074	
Hot cupboard thermostat ELE0304		Oven thermostat 350°C 08426A	

8. MAINTENANCE

8.1. Electric oven: changing the heating element

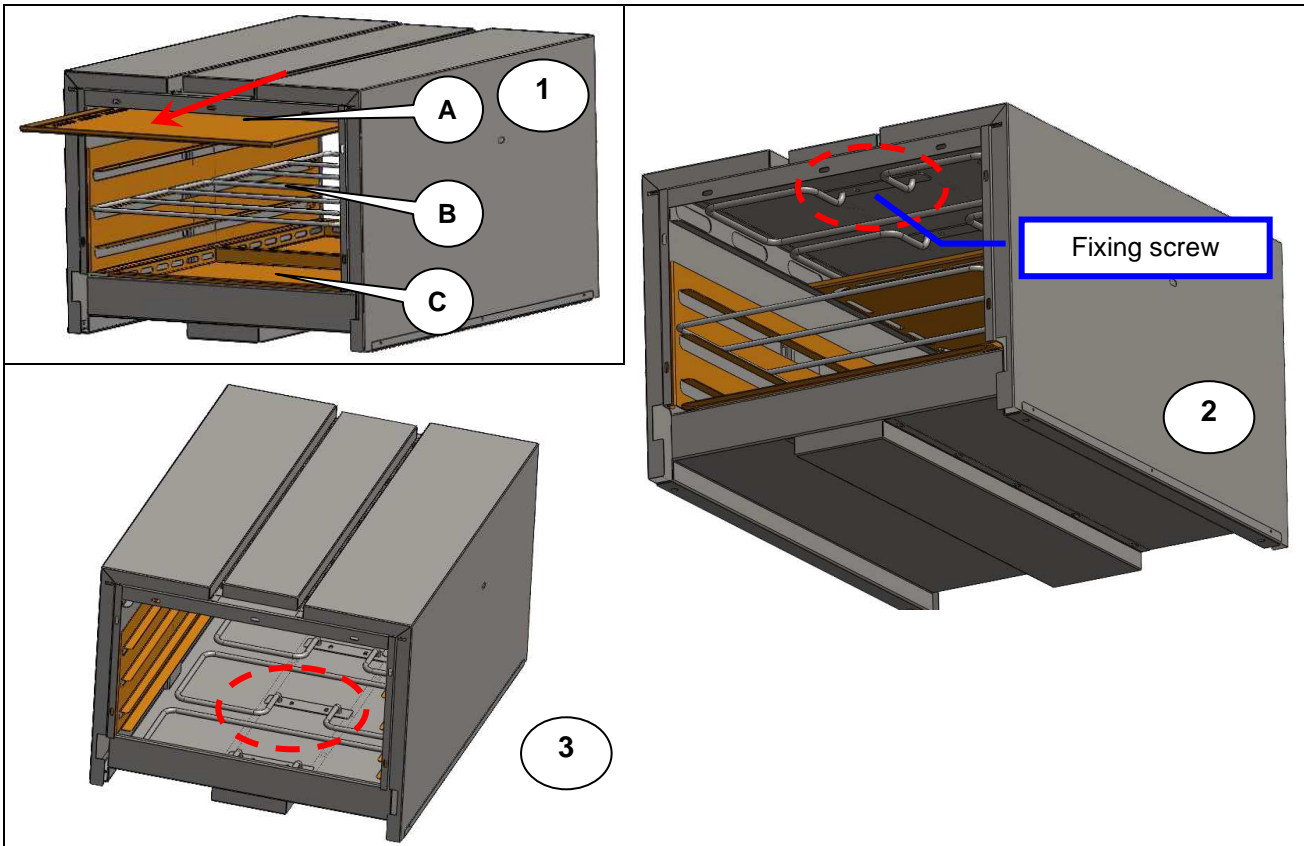

• Removing the heating elements

- Open the oven door,
- Remove the enameled vaults (A),
- Remove the grids (B) then the mild steel bases (C),
- Unscrew the screws that fix the heating elements (2) and (3).

8.2. Hot cupboard: changing the heating element

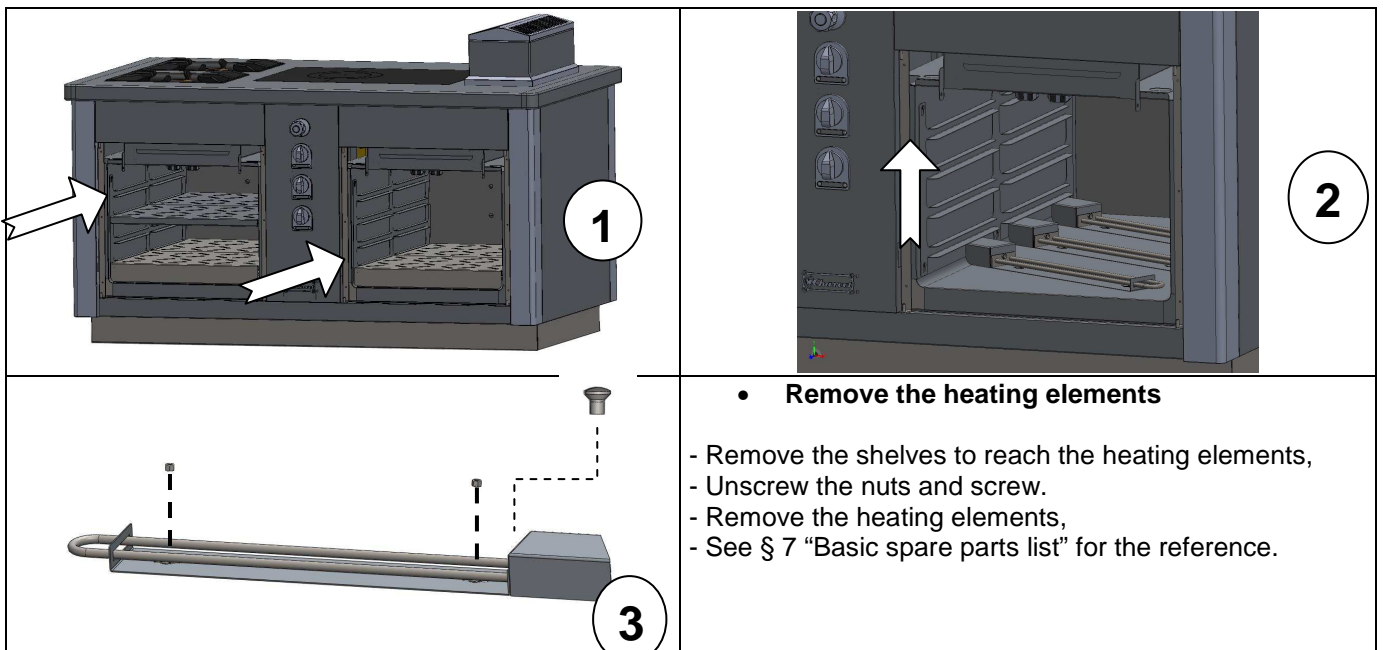

• Remove the heating elements

- Remove the shelves to reach the heating elements,
- Unscrew the nuts and screw.
- Remove the heating elements,
- See § 7 "Basic spare parts list" for the reference.

8.3. Changing the solenoid valve

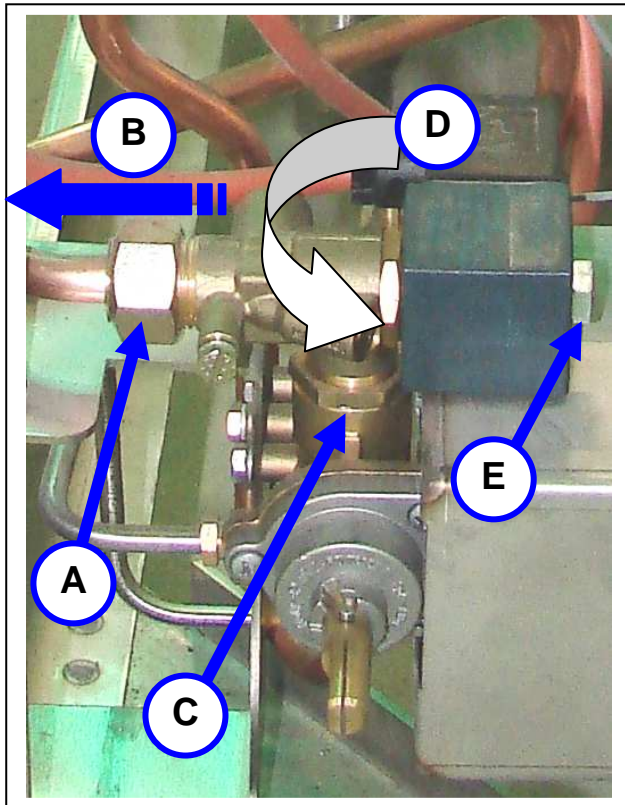

- **Changing the solenoid valve**

- Unscrew the nut (A) and pull the copper pipe (B) to the left very carefully,
- Unscrew the nut (C) and swivel (D),
- Unscrew the nut (E) to remove the solenoid valve.

9. Exploded view of a plancha

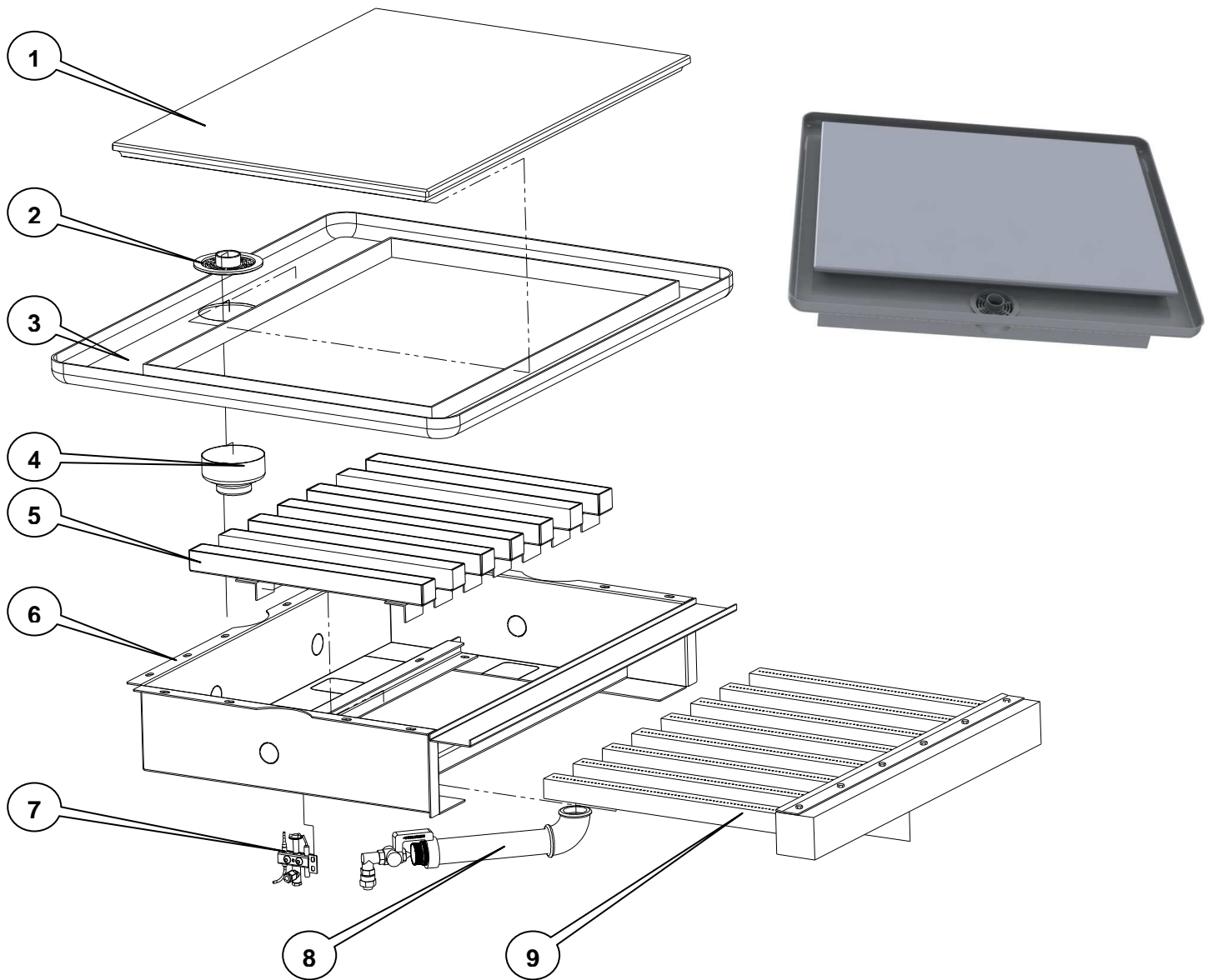

Mark	Code	Description
01		Chrome steel plate
02		Bespoke strainer
03		Peripheral channel around the plate
04		Sluice gate
05		Refractory support for burner
06		Combustion chamber
07		Support for the thermocouple pilot light
08		Venturi set
09		Enameled burner

GMC 850 GAS CHROME/CAST IRON PLANCHA

DESCRIPTION	EXTEND CONCEPT
GMC0022	MODULE 850
GMC0081	
GMC0054	
GMC0089	



User's Instructions

CHARVETPaul s.a.

F-38850 – CHARAVINES
Tel.: +33 (0) 476 066 422
Fax: +33 (0) 476 557 875
Email: info@charvet.fr
Email: sav@charvet-sa.fr



MANUAL: GMC 850 GAS CHR/CAST IRON PLANCHA
Ind. A; Date of creation: 24/09/2009
Updated on:

SUMMARY

1.	INTRODUCTION.....	3
2.	PRIOR TO STARTING UP.....	3
3.	STARTING UP	3
3.1.	CAST-IRON PLANCHA	3
3.2.	CHROME STEEL PLANCHA WITH THERMOSTAT	4
3.3.	ELECTRIC OVEN.....	4
3.4.	ELECTRIC HOT CUPBOARD	5
3.5.	STARTING THE WATER FLUSHING.....	5
4.	SWITCHING OFF	6
5.	MAINTENANCE.....	6
5.1.	CLEANING THE STAINLESS STEEL SURFACES	6
5.2.	CLEANING THE OVEN.....	6
5.3.	MAINTENANCE OF THE MILD STEEL BASE, OVEN SHELF AND SHELF RUNNERS (IN AN ELECTRIC OVEN)	7
5.4.	ELECTRIC HOT CUPBOARD	7

1. INTRODUCTION

- A) Our equipment is for professional use only and must be used by qualified staff.
- B) The equipment must be installed in compliance with local codes and bylaws. It must be installed in a kitchen equipped with an adequately sized mechanical extraction system.
- C) Appliances may be installed side by side or against walls of non combustible material. Distance to combustible material shall be no less than 10 cm.
- D) It is imperative to call for a qualified engineer for all new installations or modifications of existing equipment.
- E) **WARRANTY:** *The warranty is mentioned in our conditions of sale. Only a qualified engineer certifies the validity of the warranty. This warranty does not cover damage due to faulty installation, misuse or inadequate maintenance.*

2. PRIOR TO STARTING UP

- Prior to starting up, it is advisable to clean the appliance in order to eliminate all dust and impurities that have accumulated during storage.
- Remove all plastic protection that wraps the stainless steel panels.
- Make sure that all controls are in good working condition before turning the gas on.
- We recommend ovens are run empty for 1 or 2 hours to avoid an unpleasant taste of new material in food.

3. STARTING UP

3.1. Cast-iron plancha

- **Ignition setting**

- Push and turn control knob counter-clockwise to the ignition symbol,
- Keep pushing thoroughly. At the same time, press the push button and wait for about 20 seconds before releasing it.
- If the pilot light blows out, try again and keep pressing control knob a bit longer.

- **Full power setting**

- To ignite the burner, keep turning control knob counter-clockwise to the full power symbol.

- **Low output setting**

- Push control knob and turn counter-clockwise to the low output symbol (small flame).

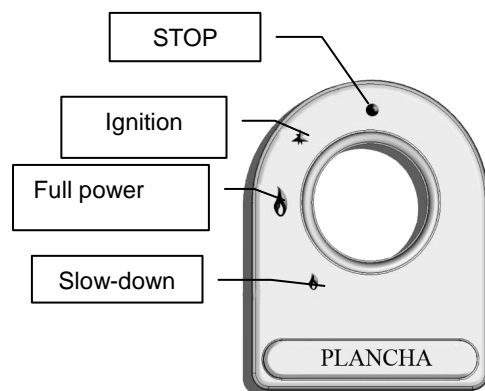

**The peripheral channel and cooking plate are very hot; wait until they cool down or take all the necessary precautions when cleaning and emptying.
Side panels and surrounding surfaces may be extremely hot after a prolonged or intensive use.**

3.2. **Chrome steel plancha with thermostat**

- Turn on the power,
- Push and turn control knob of the burner to the left and up to the "full power" position



(fig. 2)

- Keep pushing thoroughly while pressing the ignition push button (fig. 3).
- Keep the control knob pressed for 20 seconds about before releasing it. The pilot light must remain ignited.

- Repeat the operation if it fails.

- When the pilot light is on, turn the control knob counter-clockwise to the desired position.



Fig.2



Fig. 3

3.3. **Electric oven**

- Turn control knob to the desired position (vault/vault-mild steel base/mild steel base); the heating indicator is alight.
- Turn thermostat to the desired temperature; the heating indicator is illuminated.
- When the desired temperature is reached, the regulation indicator is darkened. The regulation thermostat will constantly adjust the temperature of the oven.

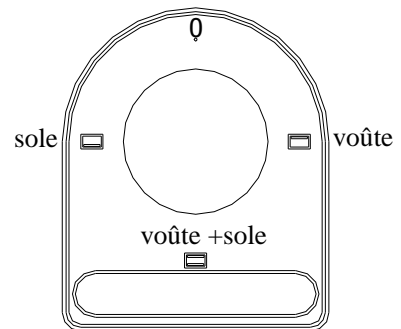

Heating red indicator

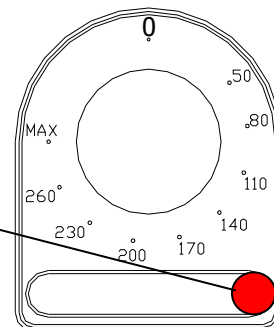

When opening the oven door in “wet” cooking mode, stay clear from the oven as vapours can escape and burn your skin very seriously!

Side panels and oven door may be extremely hot after a prolonged or intensive use. Be careful to open the door only with the handle.

3.4. **Electric hot cupboard**

- **The appliance is ON.**

- Turn the regulation thermostat knob to the desired temperature: The orange indicator remains illuminated until the desired temperature is reached.



3.5. **Starting the water flushing**

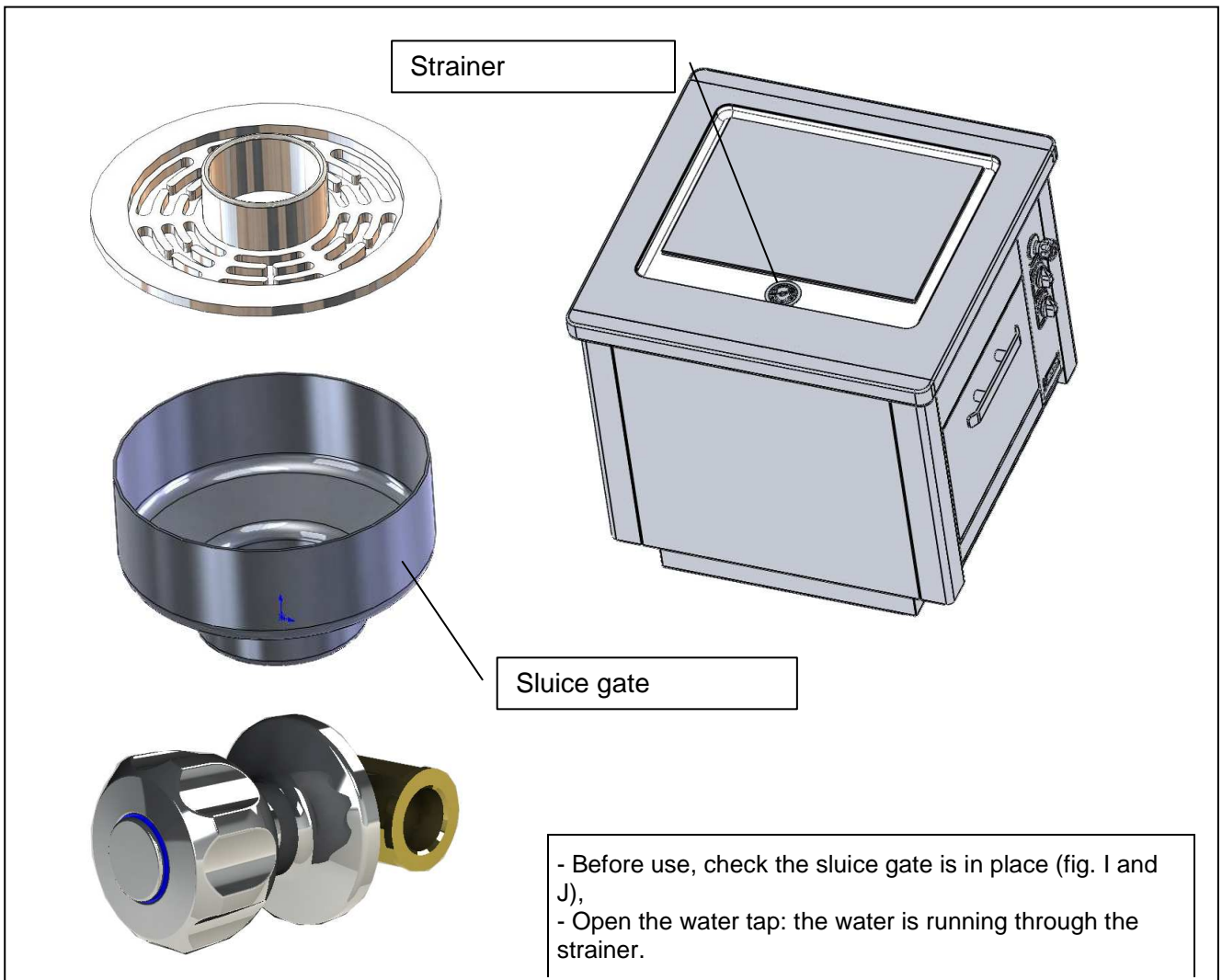

4. SWITCHING OFF

At the end of the day, cut off gas supply or/and switch off electricity at the mains.

5. MAINTENANCE

Before doing anything on the appliance, wait until cooking areas has cooled down.

5.1. Cleaning the stainless steel surfaces

- Turn off the apparatus.
- After each service and before each cleaning operation, we advise you to disconnect the appliance from the mains.
- Wash with a sponge in soapy water (or any other *neutral* cleaning product).

Note: Do not use bleach or any other acidic product – even well diluted.

Warning: Dry the cooking plate very carefully to avoid rusting. Then clean with a greasy cloth.

Note: The sluice gate has to be put back in place after each cleaning.

5.2. Cleaning the oven

To avoid fumes due to greases, stains and food particles, we recommend you to clean all the oven internal sides every day.

- The mild steel base can be removed to be cleaned. The burner housing can be cleaned as well.
- The shelf runners can also be removed to be cleaned
- Wash the oven with a sponge in soapy water (or any other neutral cleaning product).
- After cleaning, rinse and dry all the parts carefully.
- Refit in order all the parts.

This appliance must not be cleaned with mechanical water jets or be subject to a deluge of water under pressure. Check that the appliance is well disconnected at the mains.

5.3. Maintenance of the mild steel base, oven shelf and shelf runners (in an electric oven)

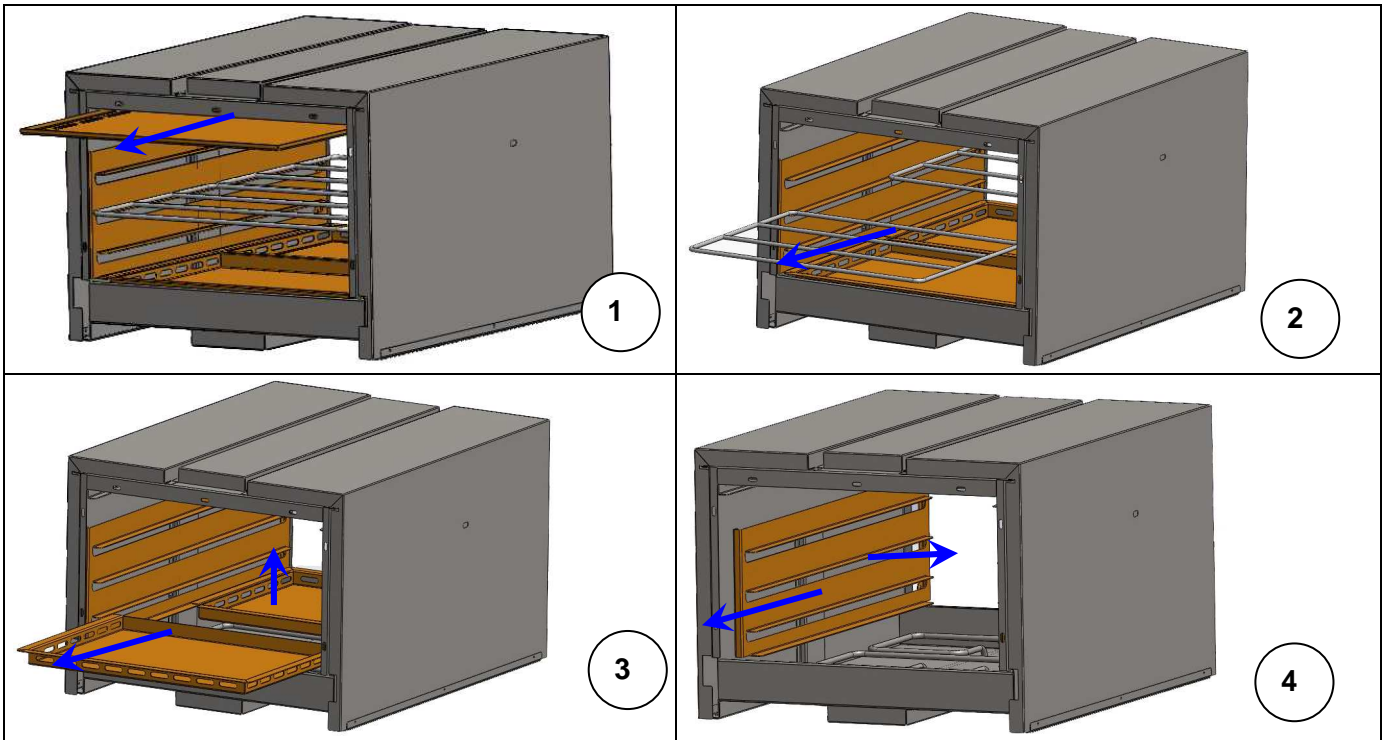

- Open the oven door,
- Remove the enameled vaults (1),
- Remove the grids (2) then the mild steel bases (3),
- Remove as well the enameled shelf runners (4),
- Clean the parts in hot soapy water,
- Dry carefully and reassemble all parts in reverse order to that described above.

5.4. Electric hot cupboard

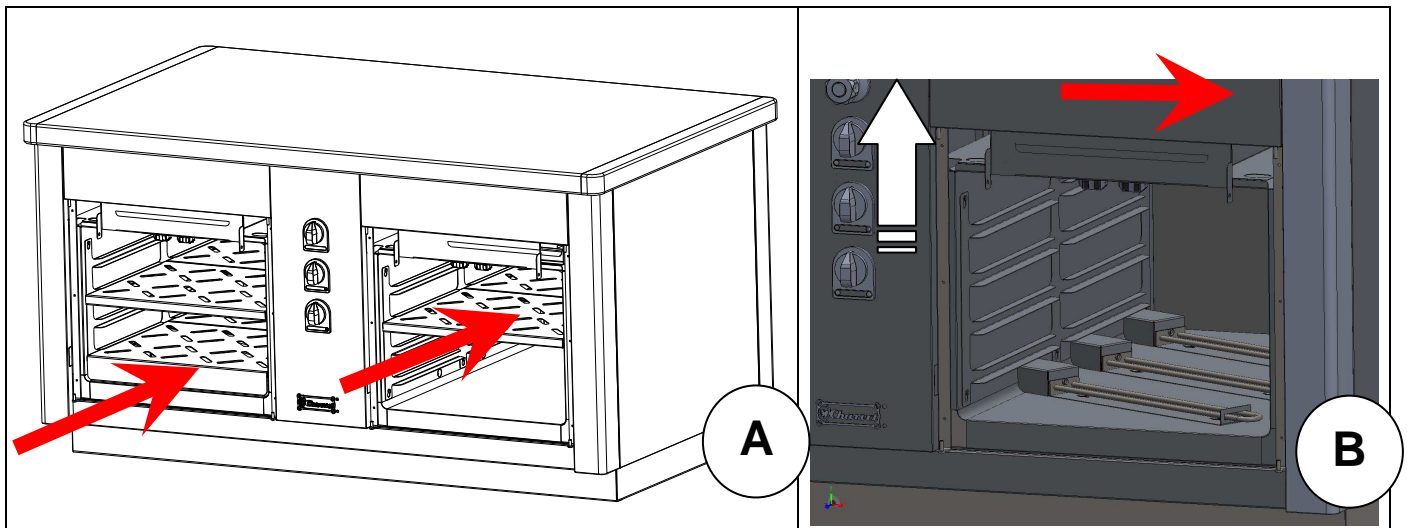

- Open the door and remove the shelves (A),
- Push them up before pulling them to the middle (B),
- Clean the parts in hot soapy water,
- Dry carefully and reassemble all parts in reverse order to that described above.





For best results, have your equipment serviced and cleaned on a regular basis by a qualified installer.

WARNING: Factory-sealed components must be serviced by neither installer nor user. Only a qualified electrician should replace the parts.

Call for your installer to replace the faulty electric components in preparation for a next use.

The manufacturer and the installer cannot be held responsible if the user neglects to ask for assistance in case of breakdown.

TRANSFER below information written on the data plate of your appliance. This will help you with maintenance problems and spare parts

	CHARVET S.A. 38850 CHARAVINES
Réf.	<input style="width: 100%;" type="text"/>
Code:	<input style="width: 50%;" type="text"/> Type: <input style="width: 50%;" type="text"/>
N°FC:	<input style="width: 50%;" type="text"/> <input style="width: 50%;" type="text"/>
N°OF:	<input style="width: 50%;" type="text"/> Rep. <input style="width: 50%;" type="text"/>
Cat.	<input style="width: 100%;" type="text"/>
Gaz	<input style="width: 100%;" type="text"/>
P (mbar)	<input style="width: 100%;" type="text"/>
ΣQ_n (kW)	<input style="width: 100%;" type="text"/>
ΣV_n (m ³ /h)	<input style="width: 100%;" type="text"/>
ΣM_n (kg/h)	<input style="width: 100%;" type="text"/>
U	<input style="width: 20%;" type="text"/> V <input style="width: 20%;" type="text"/> Hz Ip <input style="width: 20%;" type="text"/>
P	<input style="width: 20%;" type="text"/> kW <input style="width: 20%;" type="text"/>
	<input style="width: 100%;" type="text"/>
MADE IN FRANCE	