

MODULE GMC 1600

Description	EXTEND CONCEPT
GMC0017	Module 1600
GMC0019	
GMC0153	



INSTALLER'S INSTRUCTIONS

CHARVET

F-38850 – CHARAVINES
Tél.: +33 (0) 4 76 06 64 22
Fax: +33 (0) 4 76 55 78 75
Email: info@charvet.fr
Email: sav@charvet-sa.fr



MANUAL: EN- GMC 1600 SOLID TOP/OPEN BURNERS
Ind. A – Created on: 15.02.2010
Updated on:

SUMMARY

<u>INSTALLER'S INSTRUCTIONS</u>	1
<u>1. INSTALLATION</u>	3
1.1. GENERAL POINTS	3
1.2. HANDLING.....	3
1.3. INSTALLATION	3
1.4. DATA PLATE.....	4
<u>2. GAS CONNECTIONS</u>	4
2.1. CHECKS BEFORE PROCEEDING.....	4
2.2. CONNECTING THE APPLIANCE TO THE GAS MAINS.....	5
2.3. CHECKS AFTER CONNECTION	5
2.4. CHECKS OF PRESSURE SUPPLY	5
<u>3. CONVERSION TO OTHER TYPES OF GAS</u>	6
3.1. CHANGING THE INJECTORS AND ADJUSTING THE AIR	6
3.2. CHANGING THE INJECTORS AND ADJUSTING AIR OF THE OVEN PILOT LIGHT.....	8
3.3. GAS ADJUSTMENT CHARTS	9
3.4. ADJUSTING THE SLOW DOWN POSITION.....	10
3.5. ADJUSTING THE SLOW-DOWN POSITION OF OPEN BURNERS	11
<u>4. POWER CONNECTION</u>	11
4.1. CHECKS BEFORE PROCEEDING.....	11
4.2. CONNECTING THE APPLIANCE TO THE ELECTRIC NETWORK.....	12
4.3. CHECKS AFTER PROCEEDING	12
4.4. ADAPTING THE APPLIANCE TO THE VARIOUS ELECTRICAL SUPPLY VOLTAGES	12
<u>5. CONNECTING THE WATER TANK</u>	13
5.1. CHECKS BEFORE PROCEEDING.....	13
5.2. CONNECTING THE APPLIANCE TO THE WATER MAINS	13
5.3. CHECKS AFTER CONNECTION	13
<u>6. WIRING DIAGRAMS</u>	14
<u>7. BASIC SPARE PARTS LIST</u>	18
<u>8. MAINTENANCE</u>	20
8.1. ELECTRIC OVEN: CHANGING THE HEATING ELEMENT.....	20
8.2. HOT CUPBOARD: CHANGING THE HEATING ELEMENT.....	20
8.3. CHANGING THE SOLENOID VALVE	21

1. INSTALLATION

1.1. General points

Installation must be undertaken in compliance with the following instructions and with local codes and bylaws. Ensure you have a suitable and sufficient risk assessment in place.

This appliance is of A-type and shall not be connected to a flue gas pipe.

The user's manual must be given to the user after installation.

1.2. Handling

It is imperative to leave the appliance on its wooden pallet for handling on site until the final installation.

Unpack and check the appliance for damage upon receipt.

In case of damage, mark delivery note accordingly and immediately (within 48 hours) notify the carrier by registered mail with acknowledgement of receipt. Notify your seller.

1.3. Installation

All local fire regulations must be adhered to.

The appliance must be installed under a suitable mechanical extraction hood.

If the apparatus is to be installed against a wall or partition, near a piece of furniture or decorative borders, it is recommended that these are made of fireproof material.

If this is not the case, they must be protected by an approved fireproof, insulating material.

If in doubt of fireproof construction of adjacent walls, distance to combustible material shall be no less than 10 cm.

Remove all plastic protection.

Install the appliance in the kitchen.

Warning



Fixed appliance:

- Check that the masonry plinth is well horizontally leveled.
- Adjust height to level the unit to a horizontal working plan of 900 mm.
- Remove the plinth (fixed with 2 screws) - see Gas Connections § 2.2 – Fig. B (5).

**Any technical action on an appliance must be undertaken by a qualified technician.
The appliance will be isolated from the gas mains by closing the gas valve.**

When the appliance is ready for use, ensure the users know how to use it properly.
(Please see the user's manual).



Warranty: The warranty is mentioned in our conditions of sale.

This warranty does not cover damage due to faulty installation, misuse or inadequate maintenance.

1.4. **Data plate**

Each appliance has its own data plate. Transfer all this information on the last page of the user's manual.

This will ease the communication between you and your client for better service.

	
<p align="center">Location of the data plate Inside cupboard / hot cupboard</p>	<p align="center">Inside open base</p>

2. **GAS CONNECTIONS**



Warnings

- **Fixed appliance:**
Connect the appliance to the gas mains using 1/2" NPT pipe and connections. Install a suitable shutoff valve (or valve + pressure regulator) in the supply line, allowing the unit to be isolated from the rest of the cooking range.

2.1. **Checks before proceeding**

Check that:

- The mains should be free of obstructions, and clean.
- Ensure that the gas supply pipe is of the correct size for minimum pressure drop according to length, elbows, and total unit capacity.
- The appliance requires a fresh air input of 2m³/h/kW (see charts).
- The type of gas used: Ensure that the appliance is set for the type of gas supplied (nature/pressure); see data plate on the appliance and label on the gas connection.

CHART			
Code	Appliance	Power (kW)	Fresh air input required (m³/h/kW)
GMC0017	MODULE 1600	37.5 kW	75 kW
GMC0019	MODULE 1600	26.5 kW	53 kW
GMC0153	MODULE 1600	26.5 kW	53 kW

2.2. **Connecting the appliance to the gas mains**

- Remove the control knobs (2) fixed with screws,
- Remove the water tap (1),
- Unscrew the 2 screws (3),
- Pull the bottom of the panel up and out,
- Connect to connection 20/27 – 3/4" -(4) located in the technical space (3).

Note: the technical space is behind the control panel.

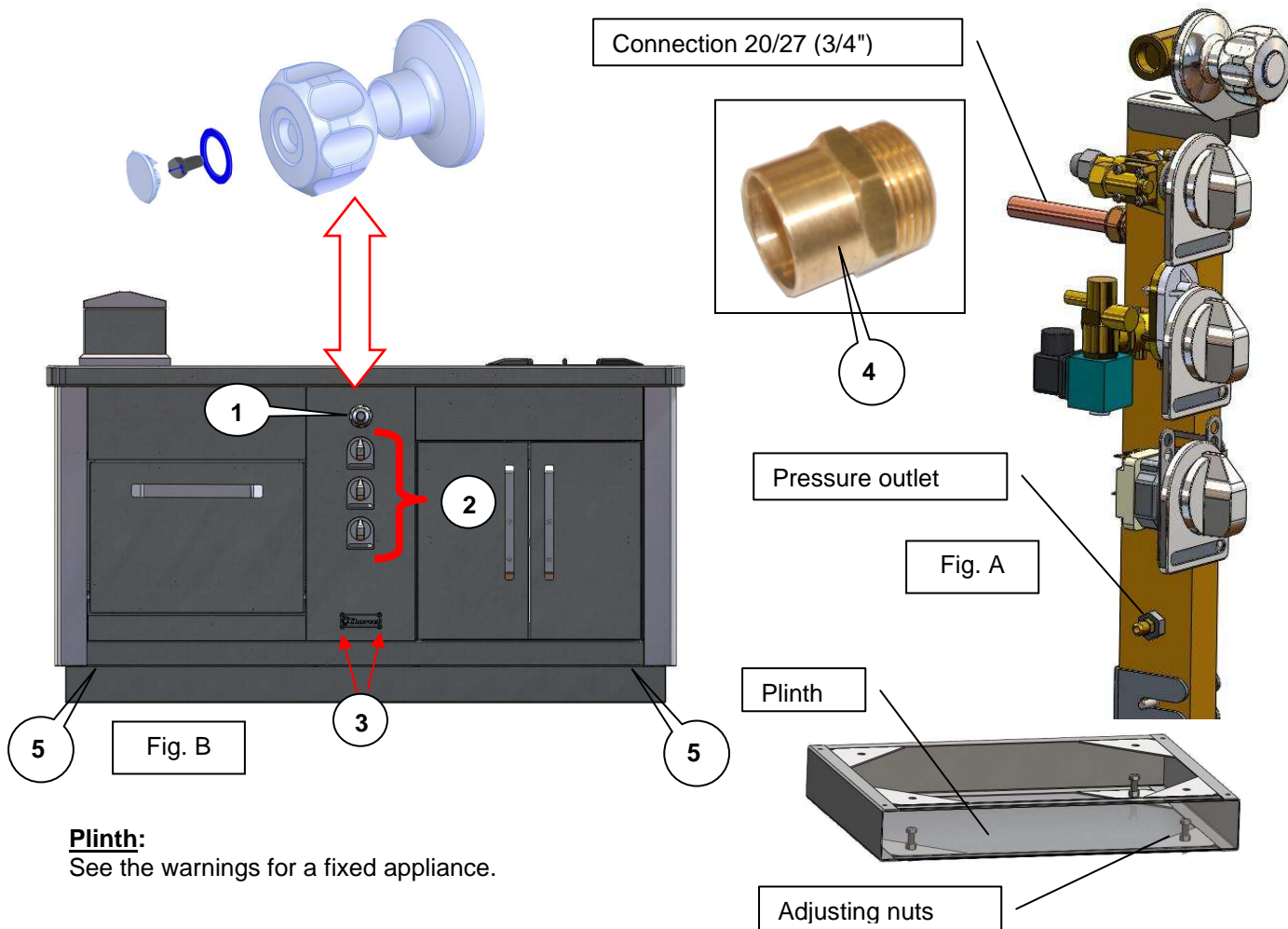

Plinth:
See the warnings for a fixed appliance.

2.3. **Checks after connection**

- Watertightness of the gas pipe,
- Supply pressure of the appliance in working state,
- The colour of the flame (blue),
- The slow-down position (see § 3.4.),
- The good working state of the appliance and its safety devices.

2.4. **Checks of pressure supply**

- Remove the control knobs,
- Remove the control panel,
- Connect the manometer on the pressure outlet located on the burner ramp,
- Switch ON appliance to maximum setting,
- Then check your figures (see § 3 "Gas Adjustments").

Note: All the appliances connected to the same gas supply should be in working state while taking the pressure supply.

3. CONVERSION TO OTHER TYPES OF GAS

Change of gas upon installation: After having replaced the injectors, ensure of the watertightness of the connection between the injector and its support.

3.1. Changing the injectors and adjusting the air

See charts § 3.3. according to the type of burners.

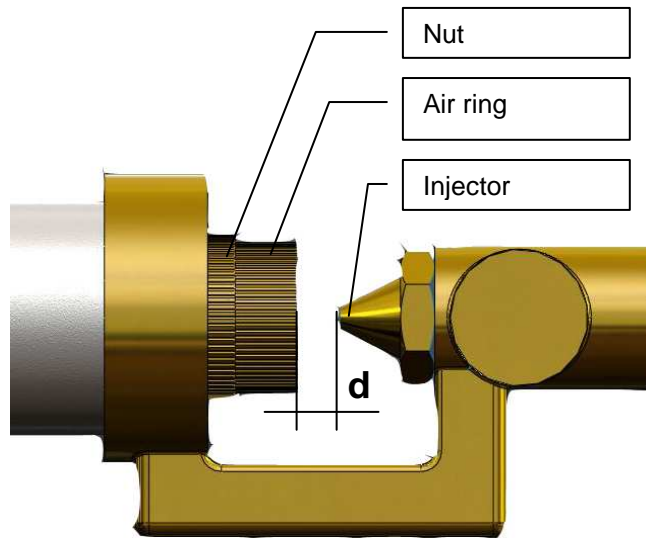

GMC Solid top / Gas oven

- Remove the solid top and refractory cement heat retention shielding to access the venturi,
- You can reach the air ring and injector,
- Unlock the air ring (nut/ring),
- Change the injector (ring spanner 12mm) (see chart § 3.3),
- Adjust distance "d", lock (nut/ring) and seal when adjustment is done.

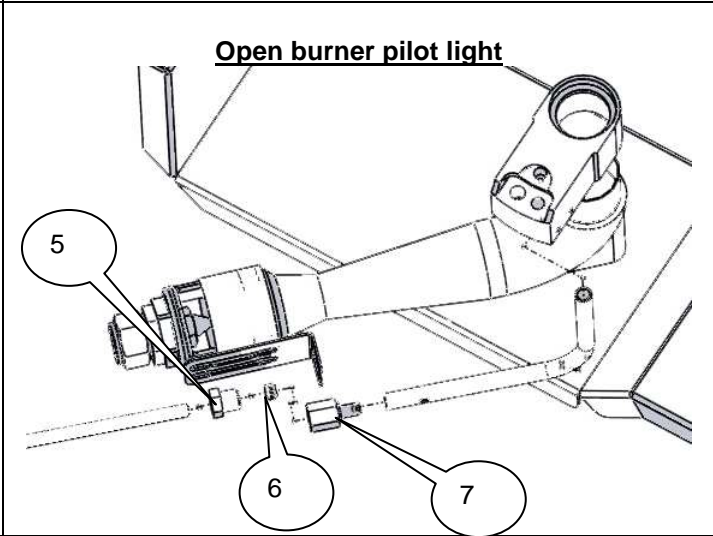
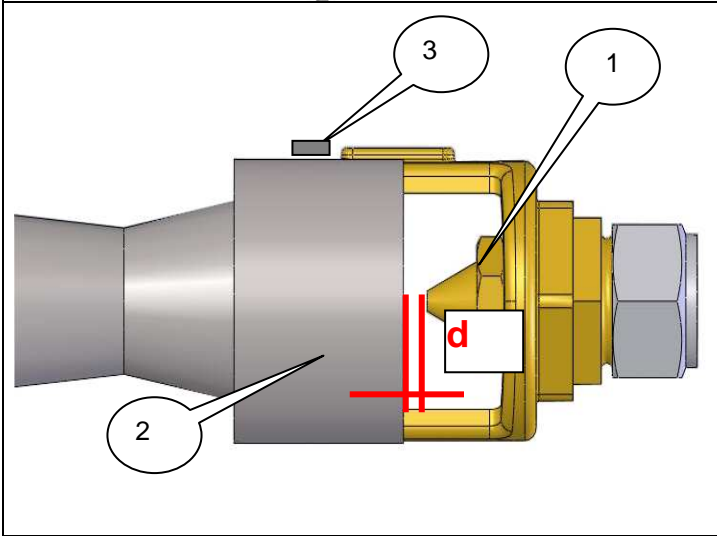
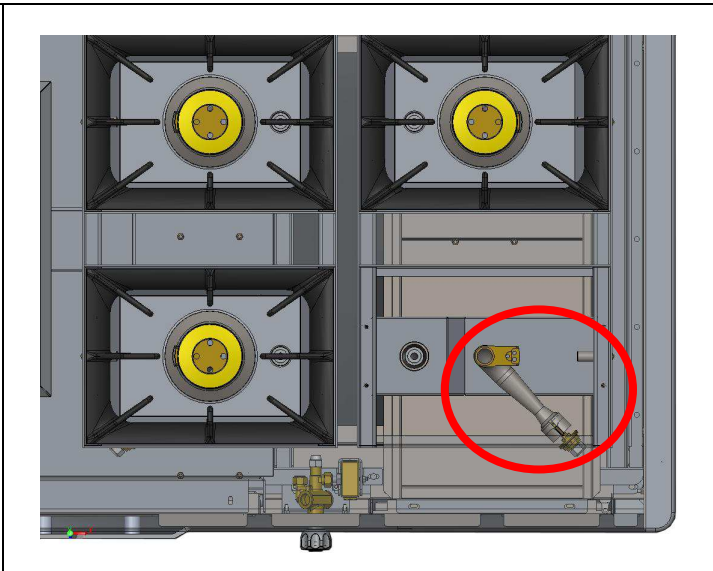
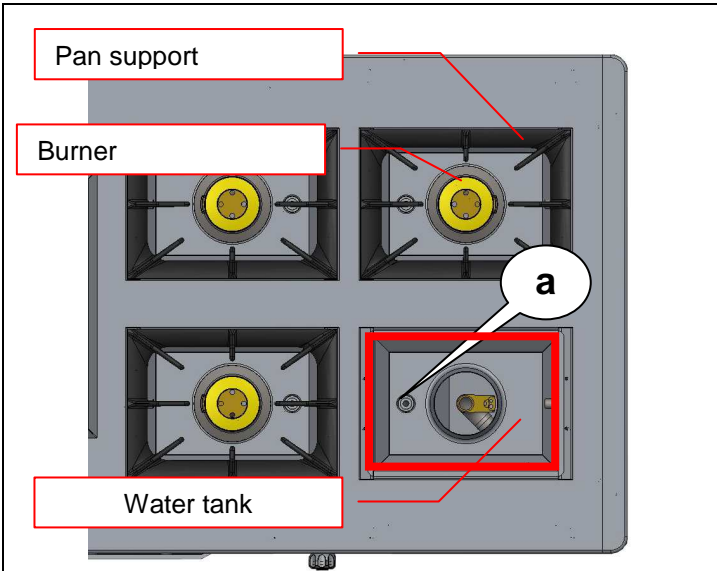

- **GMC Open Burners**

- Remove the cast iron grid and burner (cap, body, spillage tray, etc.),
 -Unlock the air ring (2), nut (3)/ring,
 - Change the injector (1) (ring spanner 17 mm) - (see chart § 3.3.),
 - Adjust distance "d", lock (nut/ring) and seal when adjustment is done.

Note: Refit in order all the parts and put back in place the sluice gate (a).

- **GMC injector & pilot light Open burners**

- Unscrew the nut (5),
 - Change the injector (7) (ring spanner 12mm) - (see chart § 3.3.),
 - Refit in reverse order all the parts: injector (7), olive (6) and nut (5).

3.2. Changing the injectors and adjusting air of the oven pilot light

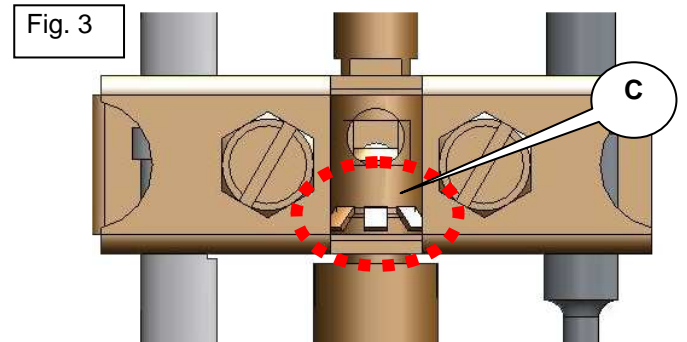
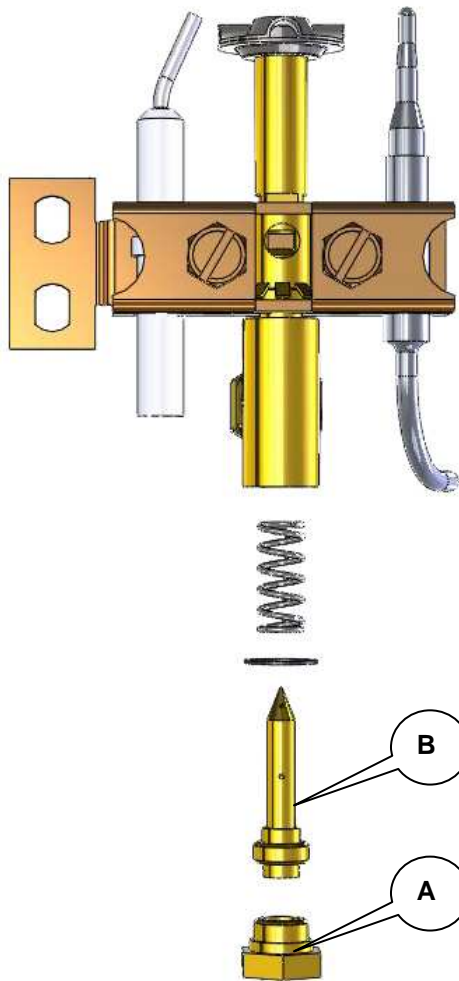

- Remove the mild steel base,
- Unscrew the nut (A) with a 11mm open-end spanner,
- Change the injector (B); see charts § 3.3.,
- Adjusting the air ring (fig. 3, C) - See chart § 3.3.

When the injector is changed, check the watertightness of the gas pipe and the good working condition of the pilot light.

3.3. Gas adjustment charts

Open Burner Ø 110 mm				
Air	Gas type & operating pressure	Mark engraved on the injector	Air adjustment d (mm)*2	Nominal calorific output (kW)*1
1	G20: Pn = 20 mbar	230	3	10
2	G 25: Pn = 20 mbar			
3	G 25: Pn = 25 mbar			
4	G 30: Pn = 29 mbar	135	Max	
5	G 30: Pn = 50 mbar			
6	G 31: Pn = 37 mbar			
7	G 31: Pn = 50 mbar			

Small cast iron plate				
Air	Gas type & operating pressure	Mark engraved on the injector	Air adjustment d (mm)*2	Nominal calorific output (kW)*1
1	G20: Pn = 20 mbar	240	Max	10.5
2	G 25: Pn = 20 mbar			
3	G 25: Pn = 25 mbar			
4	G 30: Pn = 29 mbar	160	Max	
5	G 30: Pn = 50 mbar			
6	G 31: Pn = 37 mbar			
7	G 31: Pn = 50 mbar			

Oven				
Air	Gas type & operating pressure	Mark engraved on the injector	Air adjustment d (mm)*2	Nominal calorific output (kW)*1
1	G20: Pn = 20 mbar	250	2	11
2	G 25: Pn = 20 mbar			
3	G 25: Pn = 25 mbar			
4	G 30: Pn = 29 mbar	170	Max	
5	G 30: Pn = 50 mbar			
6	G 31: Pn = 37 mbar			
7	G 31: Pn = 50 mbar			

- 1 – Measured power over lower calorific power of the gas (HI) for one open burner.
 2 - Adjustment of measured primary air according to fig. 1.

Pilot light		Open burners	Open burners	Oven	Oven
Air	Gas type & operating pressure	Mark engraved on the injector	Air adjustment	Mark engraved on the injector	Air adjustment
1	G20: Pn = 20 mbar	35	none	40	none
2	G 25: Pn = 20 mbar				
3	G 25: Pn = 25 mbar	20	none	20	none
4	G 30: Pn = 29 mbar				
5	G 30: Pn = 50 mbar				
6	G 31: Pn = 37 mbar				
7	G 31: Pn = 50 mbar				

3.4. Adjusting the slow down position

Output adjustment is done in factory (thermostatic control).
Only qualified staff can do the adjustment.
It could be necessary to adjust it.

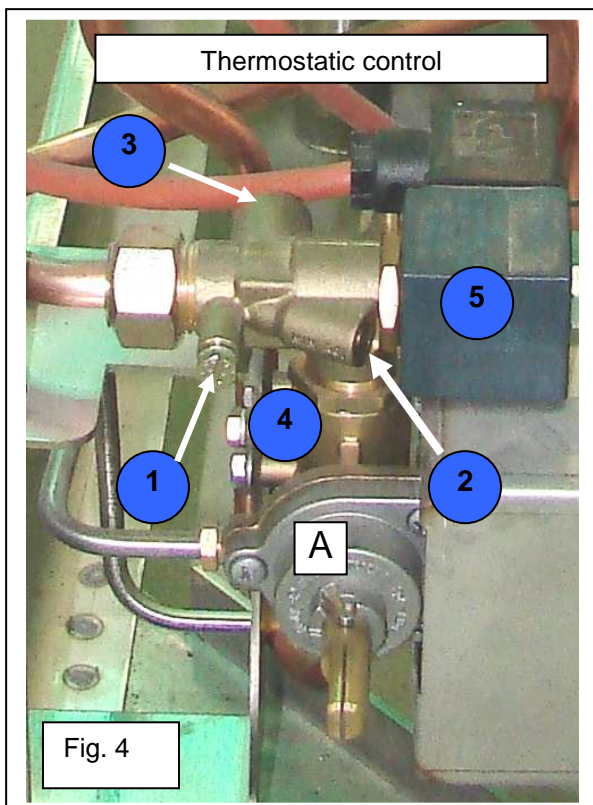
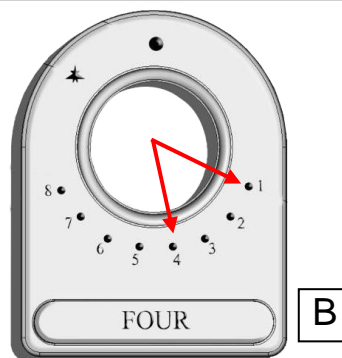

Fig. 4



This operation must be carried out very quickly and before the thermostat responds and the burner turns to the maxi output position.
Note: The maximum output position reduces the flames to ¼ of their size. The burner must remain alight when proceeding from the maximum output position to the minimum output position.

- 1) Pressure outlet
- 2) Mini output screw
- 3) Maxi output screw
- 4) Thermostatic control

• Adjusting the oven slow-down position

- Remove the control panel (see "Gas connection" § 2.2.).
- Refit the control knob (A).
- Ignite the burner and preheat for 15mn about with the door closed. Set thermostatic control in positions 3-4, then in position 1 (Fig. B).
- Screw (3) to reduce the maxi output and unscrew to increase it.
- Screw (2) to reduce the mini output and unscrew to increase it.
- Pressure can be measured from the pressure outlet (1) (Fig. 4).

3.5. Adjusting the slow-down position of open burners

*Note: The burner must remain alight when changing from maximum output to minimum output.
See § "Adjusting the slow-down position."*

"Slow-down" screw

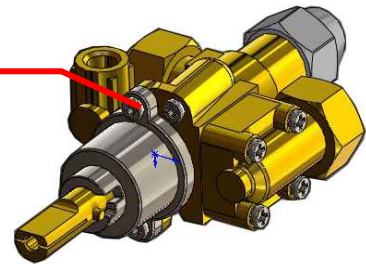

- Remove the control knobs,
- Remove the control panel (see "Gas connection" § 2), then refit the control knob,
- Start the appliance up (see the user's manual - § 2.),
- Set control knob to the slow-down position,
- Adjust the slow-down screw: To increase the slow-down, turn counter-clockwise.

4. POWER CONNECTION



Warnings

**The appliance must be earth wired.
It is dangerous to connect the appliance unless it is earthed.
We cannot be held responsible for accidents due to non existent or incorrect earth link connection.**

Fixed appliance:

Check that the electric network is equipped with all-pole circuit breakers having a cross section of 3.5 mm at least. All electrical equipment must be in compliance with the standard EN 60335-1.

WARNING:

Use a standardized cable (245 IEC 57 or 245 IEC 66) or other approved cable with the same characteristics.

All controls and checks below are done when the appliance is switched off and cold.

4.1. Checks before proceeding

Check that:

- The electrical voltage of the supply is compatible with the voltage of the apparatus (see data plate and § 5),
- The cable is fixed properly,
- The connections are tight enough,
- The section of the cable is of correct size according to the voltage of the apparatus.

4.2. **Connecting the appliance to the electric network**

Electric ignition:

- Unscrew the front control panel to access the connection box (see § 2 “Gas connection”, fig. A),
- Thread cable through the terminal box (fixed with 2 screws),
- Connect cable to the terminals, and follow the information written on the terminal box.
- Before reassembling the parts, check the electrical equipment is properly insulated (cable).

Note: The ignition push buttons and indicators should remain in place.

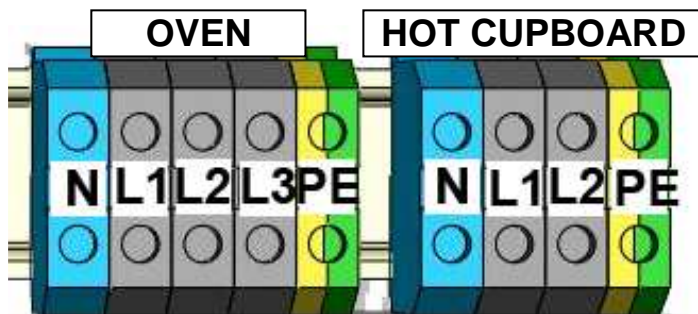

4.3. **Checks after proceeding**

- The appliance is earth wired (see the warnings),
- The electric equipment is well isolated from the rest of the equipment,
- The appliance is in good working order (ignition, thermostat, etc.).

STARTING UP: See the User's Manual.

4.4. **Adapting the appliance to the various electrical supply voltages**

Voltages available	→	1~230V + E	3~230V + E	3~400V + E
Various voltages	↓			
	Wiring diagrams #	S = standard coupling		
Hot cupboard	TR0038	S	A	A
Electric ignition	TR0087	S	A	A
Electric oven	TR0101	S	A	A
A → Coupling possible B → Please consult Charvet C → Coupling impossible D → No voltage available				

5. CONNECTING THE WATER TANK

5.1. Checks before proceeding

- Purge the supply water pipe and clean the filter,
- Check that both siphon and waste pipe are free of obstructions.

5.2. Connecting the appliance to the water mains

- Remove the control panel (See § 2 “Gas connection”, fig. A),
- Connect the water supply pipe to the connection 15/21 (1/2") of the water tap.

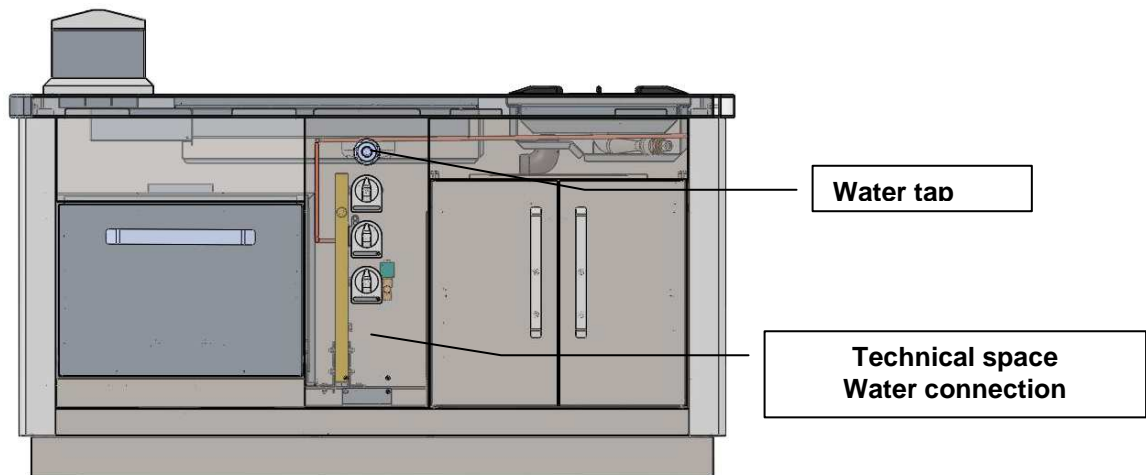

5.3. Checks after connection

Check that:

- The water system is well watertight,
- The water circuit is in good working state,

Set the water flow to obtain a regular and low flow when the water tap is fully opened. This can be done by reducing the flow at the water connection of the appliance.

6. WIRING DIAGRAMS

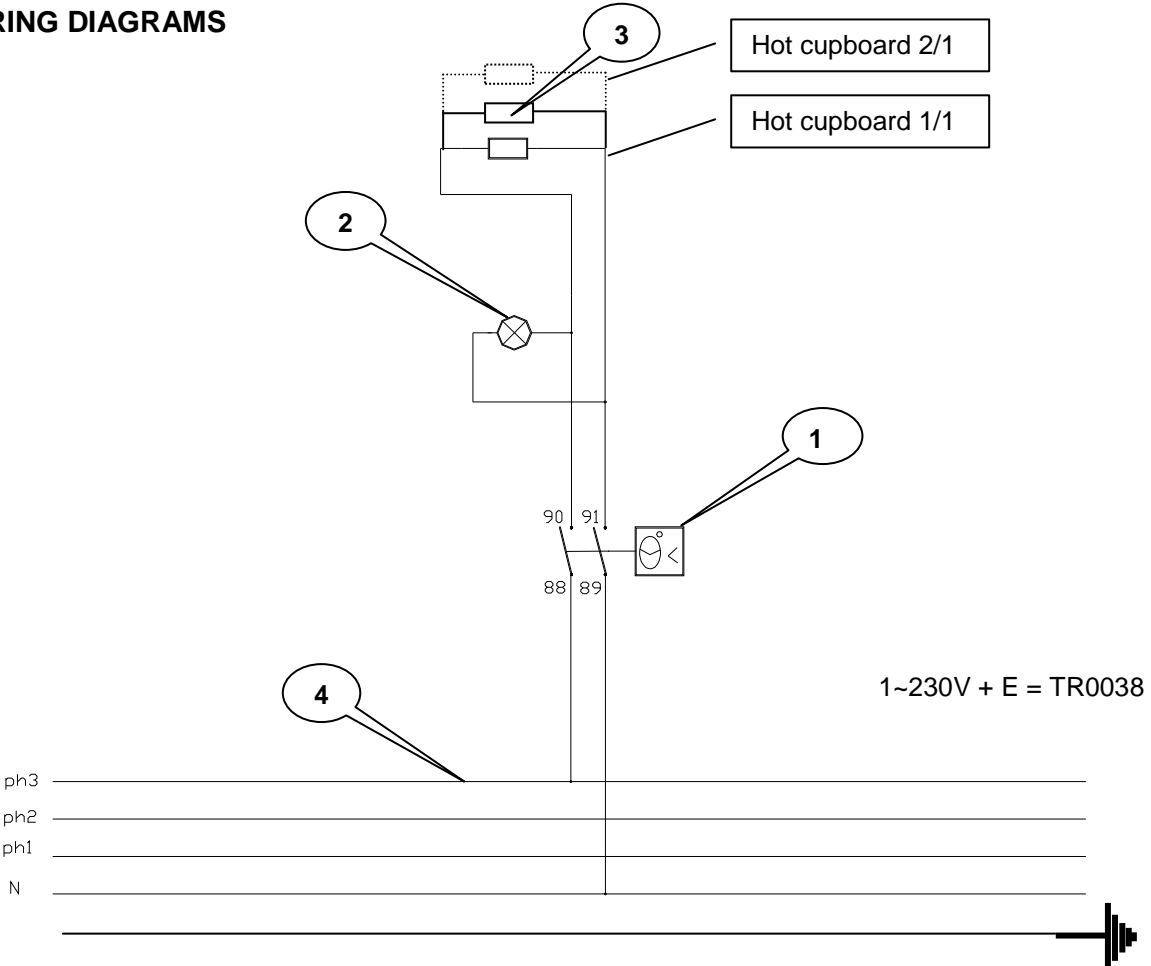

NOMENCLATURE: Hot cupboard – single phase 230 V

Mark	Code	Description	Quantity
01	ELE0304	Regulation thermostat	1
02	ELE0434	230V heating indicator	1
03	ELE0231	Heating element 230V 600W	2
04	02466A	Terminal	3
04	03575A	Viking earth terminal	1

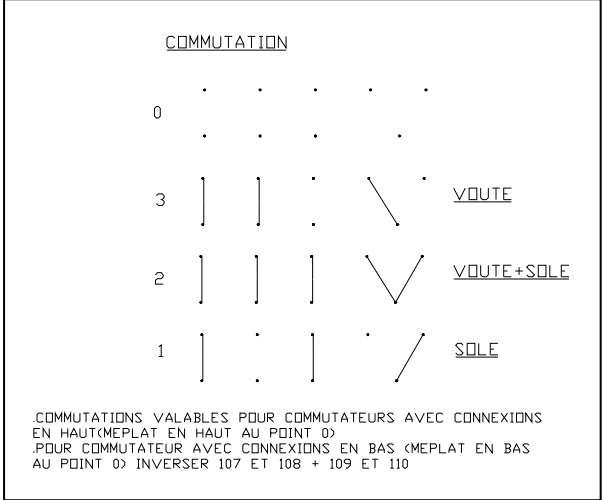
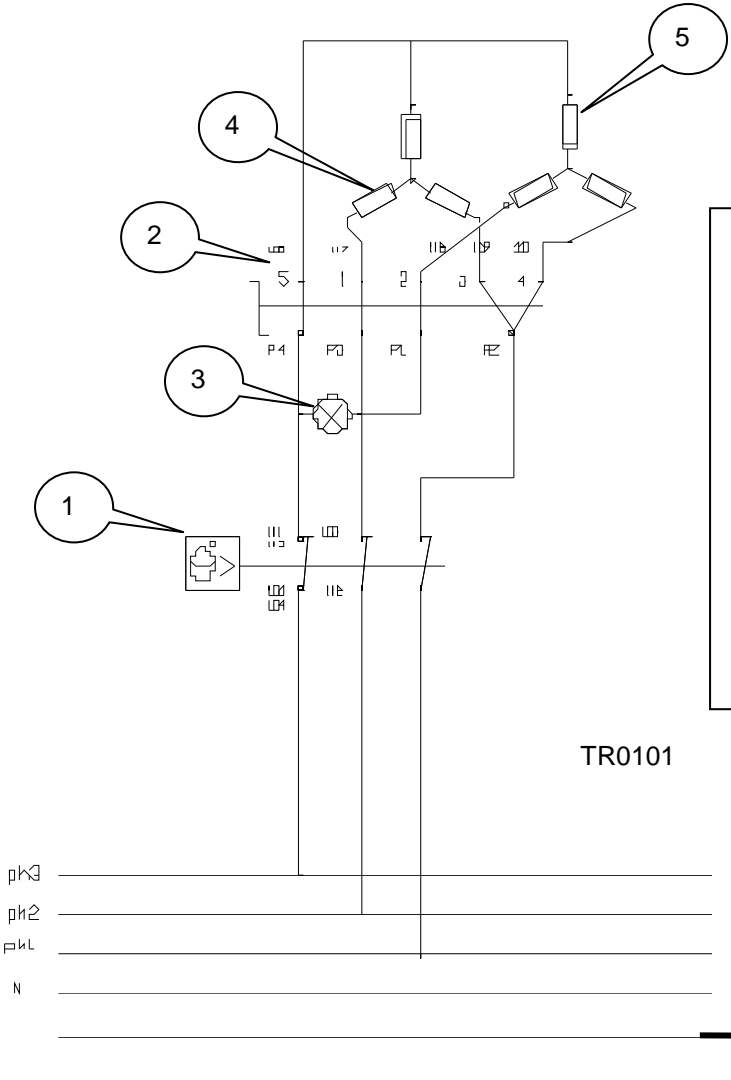

TR0101

Wiring diagram valid for switches having a rod with meplat up (set at 0).

For switches having a rod with meplat down below (set at 0), reverse:
 - 107 and 108
 - 109 and 110

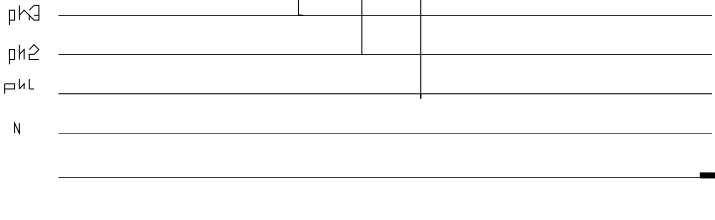

NOMENCLATURE: Electric pass-through oven

Mark	Code	Description	Quantity
01	08426A	Thermostat 350°C	1
02	Ele0074	4-position switch	1
03	Ele0435	400V heating indicator	1
04	502632	Vault heating element 1200W	3
05	502637	Mild steel base heating element 1800W	3

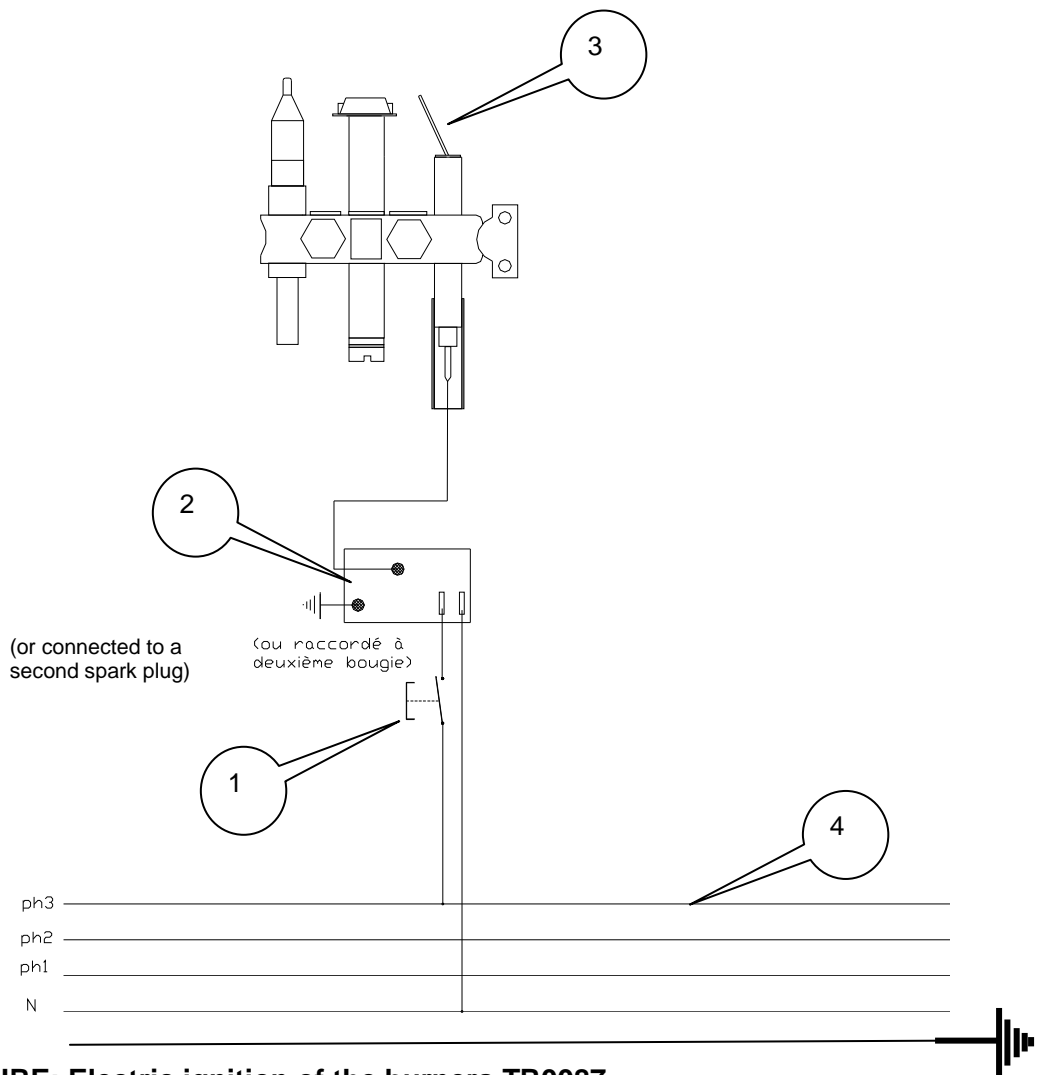

NOMENCLATURE: Electric ignition of the burners TR0087



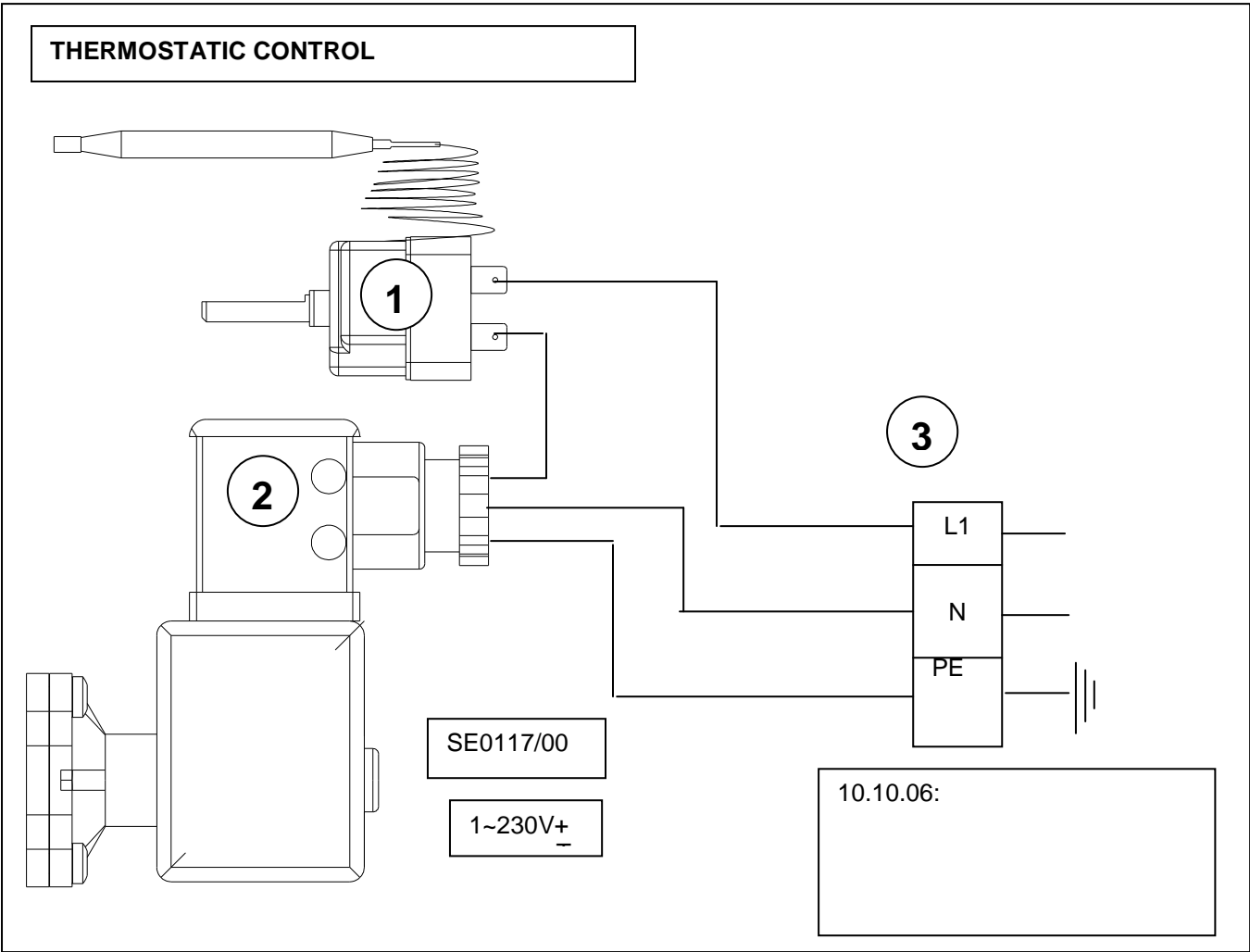





Mark	Code	Description	Quantity
01	ELE0018	Electric ignition push button	1
02	GAZ0002	2-point or 4-point ignitor	1
03	07010A	Spark plug	1
04	02466A	Terminal	3
04	03575A	Earth terminal Vicking	1

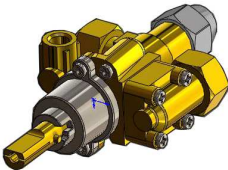
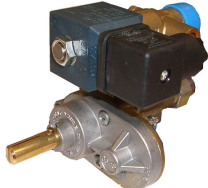

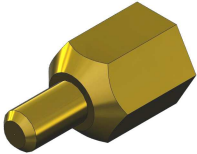



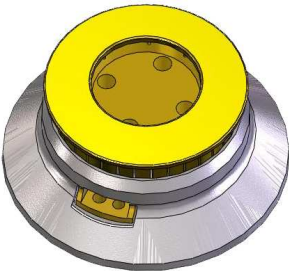

NOMENCLATURE: THERMOSTATIC CONTROL (SE0117/00)

Mark	Code	Description	Quantity
01	08426A	Thermostat	1
02	08425A	Solenoid valve	1
03	02468A	Terminal	1

7. BASIC SPARE PARTS LIST

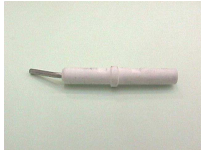
Description / Code	Photograph	Description / Code	Photograph
Gas tap 08094A		Thermostatic control 080425A	
Gas injector Open burners G20/G25 Ø 2.30 natural 06984A G31 Ø 1.35 Propane 07146A		Gas injector Oven G20/G25 Ø 2.50 natural 00209A G31 Ø 1.70 Propane 06250A	
Pilot light injector Open burners G30 - G31 Ø 0.20 Propane 06988A G20/G25 06989A Ø 0.35 natural		Gas injector SOLID TOP G20/G25 Ø 2.40 natural 00208A G31 Ø 1.35 Propane 00200A	
Thermocouple 00290A		3-flame pilot light 07551A	
Burner 8 kW 100103 Burner cap 08067A Flame ring 07822A Burner body 08098A Safety device Code 08097A		Pilot light injector oven G30, G31 Ø 0.20 Propane 06988A G20/G25 00559A Ø 0.40 natural	

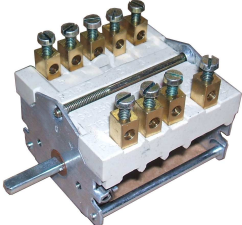
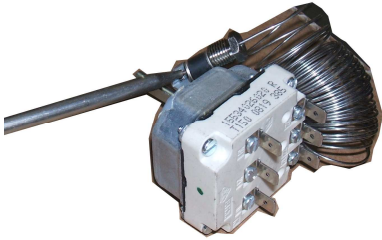
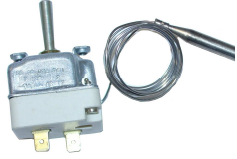
Description / Code	Photograph	Description / Code	Photograph
Orange indicator Ele0434 Red indicator Ele0435		Push button for ignition 08865A	
thermostatic control coil 08936A		4-point ignitor 230V GAZ0002	
Heating elements Electric oven: Mild steel base 1200W 502632 Vault 1800W 502637		Electrode 07010A	
Heating element (hot cupboard) 230V ELE0231		Oven switch Ele0074	
Hot cupboard thermostat ELE0304		Oven thermostat 350°C 08426A	

8. MAINTENANCE

8.1. Electric oven: changing the heating element

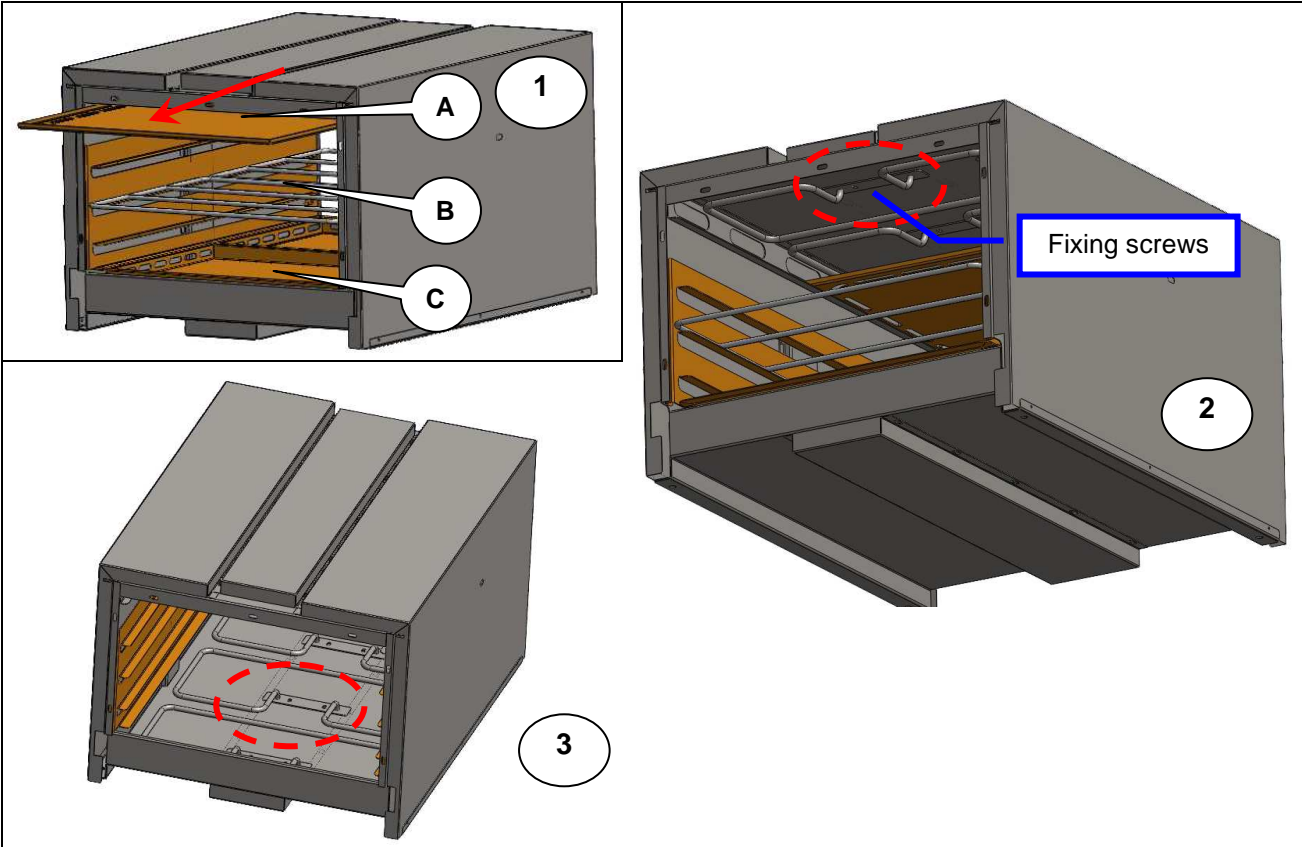

- Open the oven door and remove the enameled vault (A),
- Remove the grid(s) (B), then the mild steel base (C),
- Unscrew the fixing screws (2) and (3) of the heating elements (vault and mild steel base).

8.2. Hot cupboard: changing the heating element

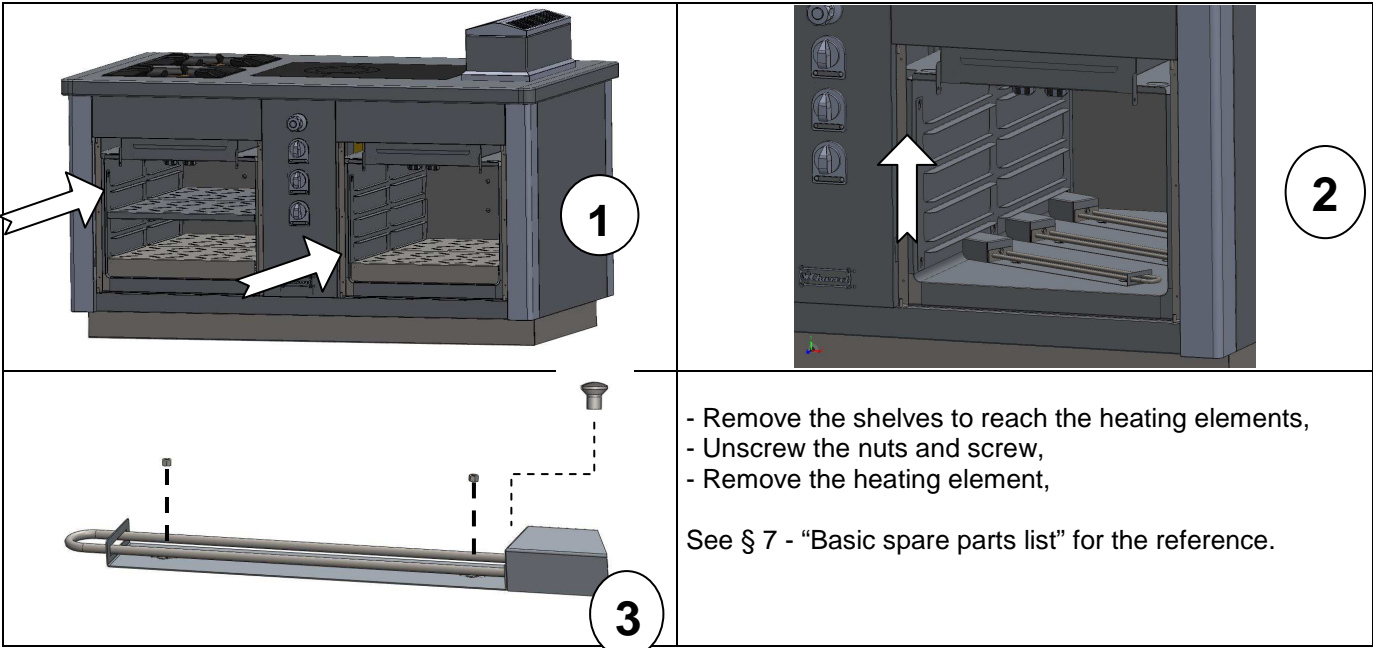

- Remove the shelves to reach the heating elements,
- Unscrew the nuts and screw,
- Remove the heating element,

See § 7 - "Basic spare parts list" for the reference.

8.3. Changing the solenoid valve

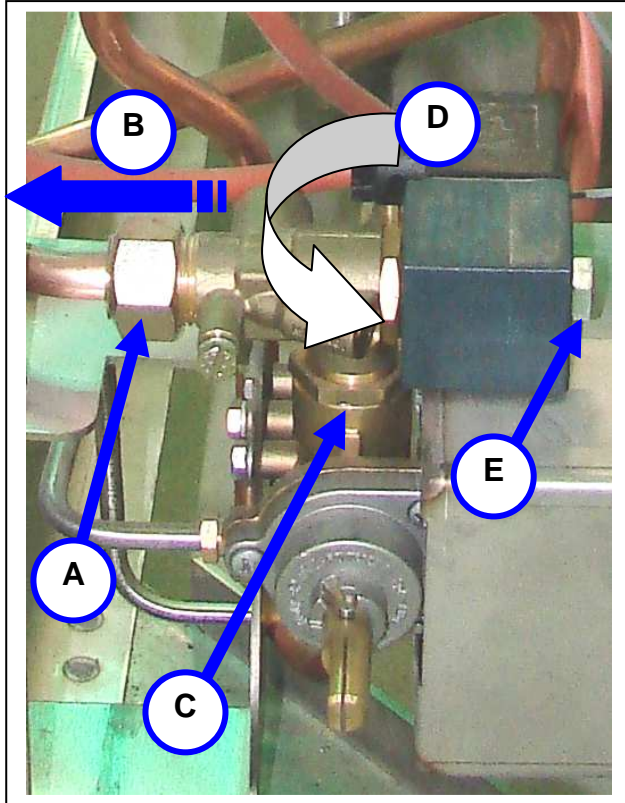

- **Changing the solenoid valve**

- Unscrew the nut (A) and pull the copper pipe (B) to the left very carefully.
- Unscrew the nut (C), swivel (D) and unscrew the nut (E) to remove the solenoid valve.

MODULE GMC 1600

Description	EXTEND CONCEPT
GMC0017	Module 1600
GMC0019	
GMC0153	



USER'S INSTRUCTIONS

CHARVET

F-38850 – CHARAVINES
Tél.: +33 (0) 4 76 06 64 22
Fax: +33 (0) 4 76 55 78 75
Email: info@charvet.fr
Email: sav@charvet-sa.fr



MANUAL: EN- GMC 1600 SOLID TOP/OPEN BURNERS
Ind. A – Created on: 15.02.2010
Updated on:

SUMMARY

<u>USER'S INSTRUCTIONS</u>	1
<u>1. INTRODUCTION</u>	3
<u>2. PRIOR TO STARTING UP</u>	3
<u>3. STARTING UP</u>	3
3.1. OPEN BURNERS.....	3
3.2. CAST-IRON SOLID TOP	4
3.3. GAS OVEN.....	5
3.4. ELECTRIC OVEN.....	5
3.5. ELECTRIC HOT CUPBOARD	6
3.6. HOW TO USE THE WATER TANK WITH THE OPEN BURNERS?	6
<u>4. SWITCHING OFF</u>	7
<u>5. MAINTENANCE</u>	7
5.1. CLEANING THE STAINLESS STEEL SURFACES	7
5.2. CLEANING THE OVEN	7
5.3. CLEANING THE SOLID TOP PLATE.....	7
5.4. MAINTENANCE: MILD STEEL BASE, OVEN SHELF AND SHELF RUNNERS (IN A GAS OVEN).....	8
5.5. MAINTENANCE: MILD STEEL BASE, OVEN SHELF AND SHELF RUNNERS (IN AN ELECTRIC OVEN)	8
5.6. MAINTENANCE: ELECTRIC HOT CUPBOARD	9
<u>6. POSSIBLE CAUSES OF BREAKDOWN</u>	9
<u>7. DATA PLATE</u>	10

1. INTRODUCTION

- A) Our equipment is for professional use only and must be used by qualified staff.
- B) The equipment must be installed in compliance with local codes and bylaws. It must be installed in a kitchen equipped with an adequately sized mechanical extraction system.
- C) Appliances may be installed side by side or against walls of non combustible material. Distance to combustible material shall be no less than 10 cm.
- D) It is imperative to call for a qualified engineer for all new installations or modifications of existing equipment.
- E) **WARRANTY:** *The warranty is mentioned in our conditions of sale. Only a qualified engineer certifies the validity of the warranty. This warranty does not cover damage due to faulty installation, misuse or inadequate maintenance.*

2. PRIOR TO STARTING UP

- a) Prior to starting up, it is advisable to clean the appliance in order to eliminate all dust and impurities that have accumulated during storage.
- b) Remove all plastic protection that wraps the stainless steel panels.
- c) Make sure that all controls are in good working condition before turning the gas on.

We recommend ovens are run empty for 1 or 2 hours to avoid an unpleasant taste of new material in food.

3. STARTING UP

General points: *Each burner is equipped with a safety thermocouple and a pilot light.*

3.1. Open burners

Ignition setting

- Push and turn control knob counter-clockwise to the ignition symbol.
- Keep pushing thoroughly. At the same time, press the push button and wait for about 20 seconds before releasing it.
- If the pilot light blows out, try again and keep pressing control knob a bit longer.

Full power setting:

- To ignite the burner, keep turning control knob counter-clockwise to the full power symbol.

Low output setting:

- Push and turn control knob counter-clockwise to the low output symbol.

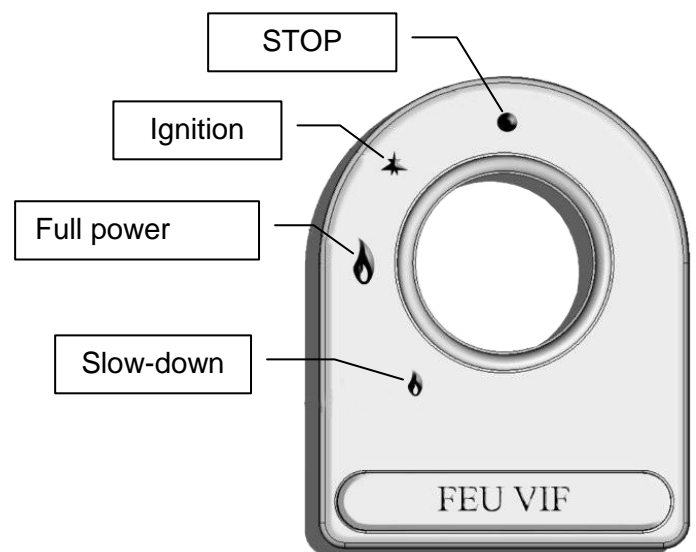

3.2. **Cast-Iron Solid Top**

- Take off the central ring.
- Push and turn control knob of the burner to the left and up to the "slow-down" position.
- Keep pushing thoroughly while pressing the ignition push button.
- Keep the control knob pressed for 20 seconds about before releasing it: the pilot light must remain ignited,
- Repeat the operation if it fails,
- When the pilot light is on, turn the control knob counter-clockwise to the "full power" position (see control panel): the burner is working at its nominal power.
- By turning the control knob to the next position (small flame) the burner is on the slow-down position.
- When done, refit the central ring.

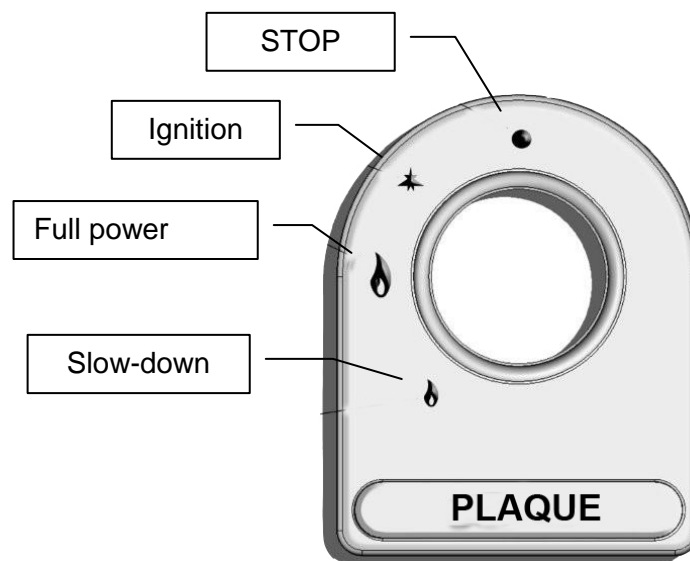

3.3. **Gas oven**

Pilot light ignition setting:

- Push and turn control knob counter-clockwise to the ignition symbol.
- Keep pushing thoroughly. At the same time, press the push button and wait for about 20 seconds before releasing it.
- If the pilot light blows out, try again and keep pressing control knob a bit longer.
- The pilot light can be seen through the hole in the mild steel base.

Temperature regulation device:

- Press slightly the control knob. Turn it to position "8". The burner starts.
- When done, choose the desired temperature.
- The temperature positions - from "1" to "8" - refer to temperatures comprised between 100°C and 350°C.

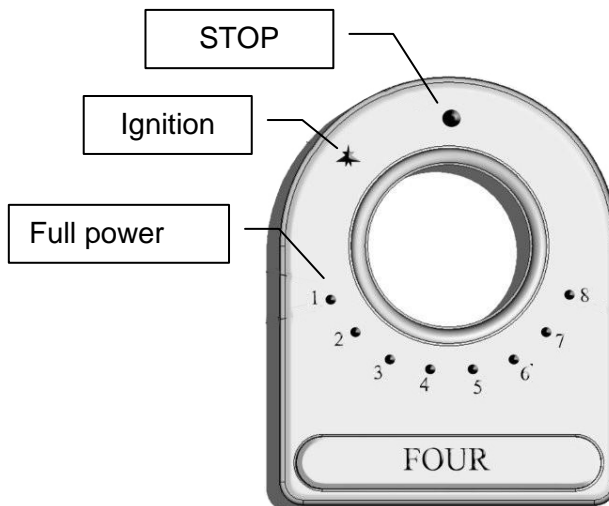

Oven racks enable different positions of shelves and trays according to the cooking time and type of foods. Nevertheless, be careful not to cook on 2 levels at the same time as it will block the burned gases route.

3.4. **Electric oven**

- Turn control knob to the desired position (vault/vault-mild steel base/mild steel base); the heating indicator is alight.
- Turn thermostat to the desired temperature; the heating indicator is illuminated.
- When the desired temperature is reached, the regulation indicator is darkened. The regulation thermostat will constantly adjust the temperature of the oven.

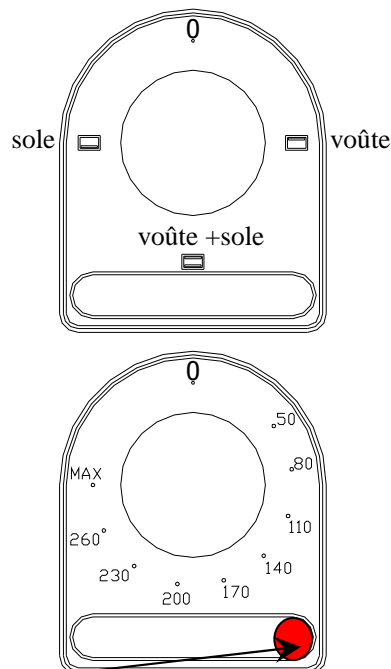

Heating indicator

WARNING:

When opening the oven door in "wet" cooking mode, stay clear from the oven as vapours can escape and burn your skin very seriously!
Side panels and oven door may be extremely hot after a prolonged or intensive use. Be careful to open the door only with the handle, and stay clear from the door.

3.5. Electric hot cupboard

The appliance is alight:

- Turn the regulation thermostat knob to the desired temperature.
- The orange indicator remains illuminated until the desired temperature is reached.



3.6. How to use the water tank with the open burners?

Fig. I

Sluice gate

Water Flushing

Water tank

Fig. J

Sluice gate Level MAXI.

Water tank

OVERFLOW EXIT

- Before using the water tank, ensure the sluice gate is in correct position (fig. I) and (fig. J).
- Open the water tap and allow filling to level MAXI of the sluice-gate.

N.B. 1: Take off the overflow device to empty the water tank.

N.B. 2: While the water tank is in use, check the watertightness of the water connection circuit.

N.B. 3: It is important to refit the sluice gate in position after each cleaning of the water tank.

4. SWITCHING OFF

At the end of the day, cut off gas supply or/and switch off electricity at the mains.

5. MAINTENANCE

Before doing anything on the appliance, wait until cooking areas has cooled down.

5.1. Cleaning the stainless steel surfaces

- Turn off the apparatus. After each service and before each cleaning operation, we advise you to disconnect the appliance from the mains.
- Wash with a sponge in soapy water (or any other neutral cleaning product).

Note: Do not use bleach or any other acidic product – even well diluted.

Cleaning the burner caps:

Clean on a regular basis to avoid corrosion.

The caps can be cleaned with a cloth soaked with water and caustic soda (1/2 glass of caustic soda/litre).

The caps can also be cleaned with white vinegar; let take effect for 2 hours (never add salt in the white vinegar solution).

Rinse thoroughly the caps, even between the slots.

Damaged burner caps and green-coloured flame will result from incorrect rinsing.

Warning: Wash the crowns and the spillage tray, rinse and dry carefully. Then clean with a greasy cloth to avoid rusting.

Note: The sluice gate has to be put back in place after each cleaning.

5.2. Cleaning the oven

To avoid fumes due to greases, stains and food particles, we recommend you to clean all the oven internal sides every day.

- The mild steel base can be removed to be cleaned. The burner housing can be cleaned as well (see § 5.4.).
- The shelf runners can also be removed to be cleaned (see § 5.4.).
- Wash the oven with a sponge in soapy water (or any other neutral cleaning product).
- After cleaning, rinse and dry carefully all the parts.
- Refit in order all the parts.

This appliance must not be cleaned with mechanical water jets or be subject to a deluge of water under pressure. Check that the appliance is well disconnected at the mains.

5.3. Cleaning the solid top plate

- Clean with an appropriate scouring pad. Grease the cast-iron plate(s) if you don't use the appliance.
- Remove the solid top plate(s) to clean the refractory cement heat retention shielding.
- The drip tray should be cleaned daily.
- Refit in order all the parts.



Warning: Clean the solid top with a Tampico brush or a wood spatula. Never clean the cast iron solid top plate with ice.
Dry the cast iron solid top plate carefully to avoid rusting. Then clean with a greasy cloth.

5.4. Maintenance: mild steel base, oven shelf and shelf runners (in a gas oven)

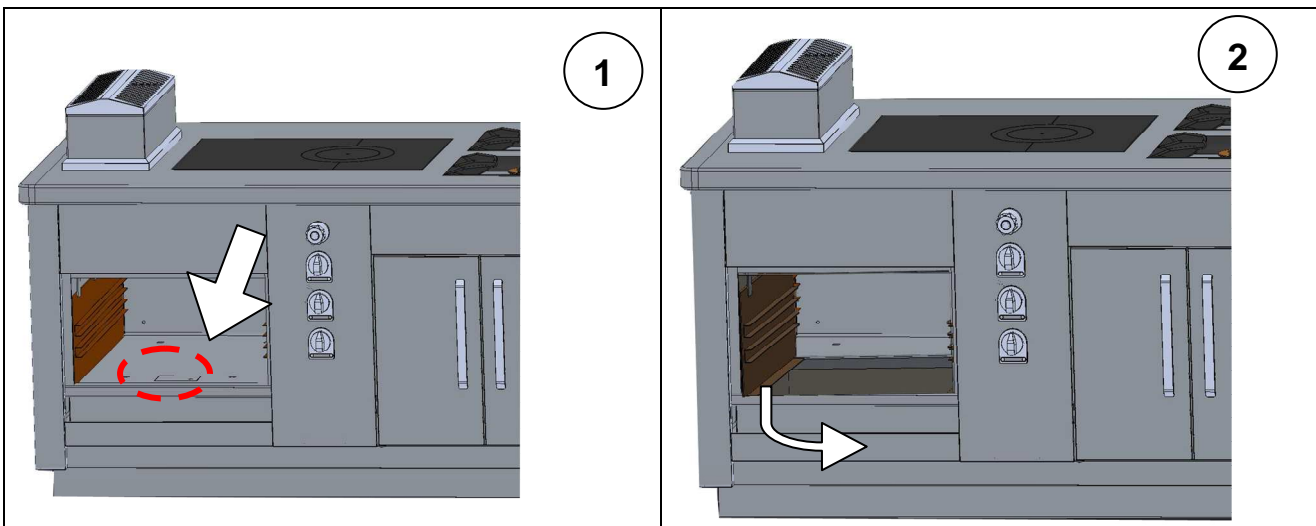

• Procedure

- Remove the oven shelf from the oven,
- Remove the mild steel base using the oblong hole (fig. 1),
- Grab the shelf runner and pull it to the middle of the oven (fig. 2),
- Then remove it from the oven.

Note: The mild steel base is very heavy. Handle with care. Weight: 23 kg

5.5. Maintenance: mild steel base, oven shelf and shelf runners (in an electric oven)

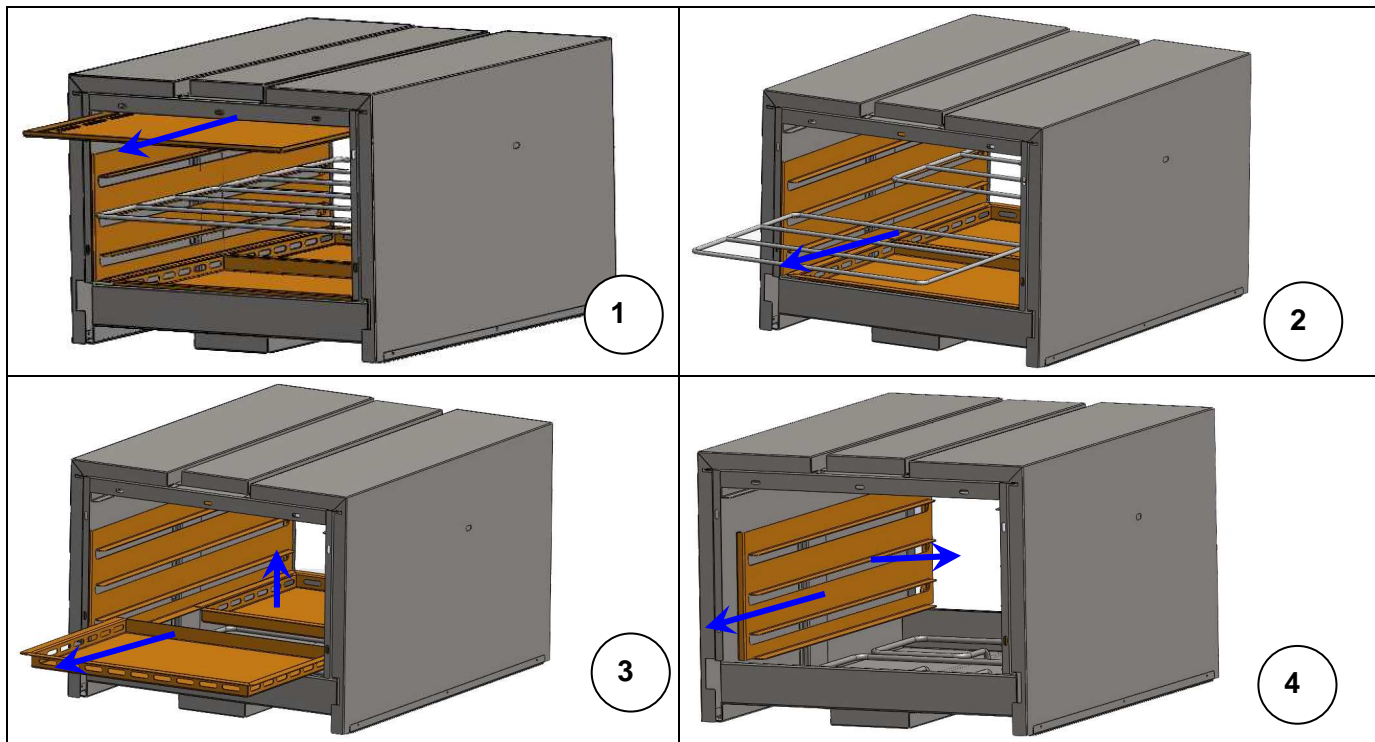

• Procedure

- Open the oven door and remove the enameled vaults (1),
- Remove the the oven shelves (2), the mild steel bases (3) and the shelf runners (4),
- Clean the parts in hot soapy water.

5.6. Maintenance: Electric hot cupboard

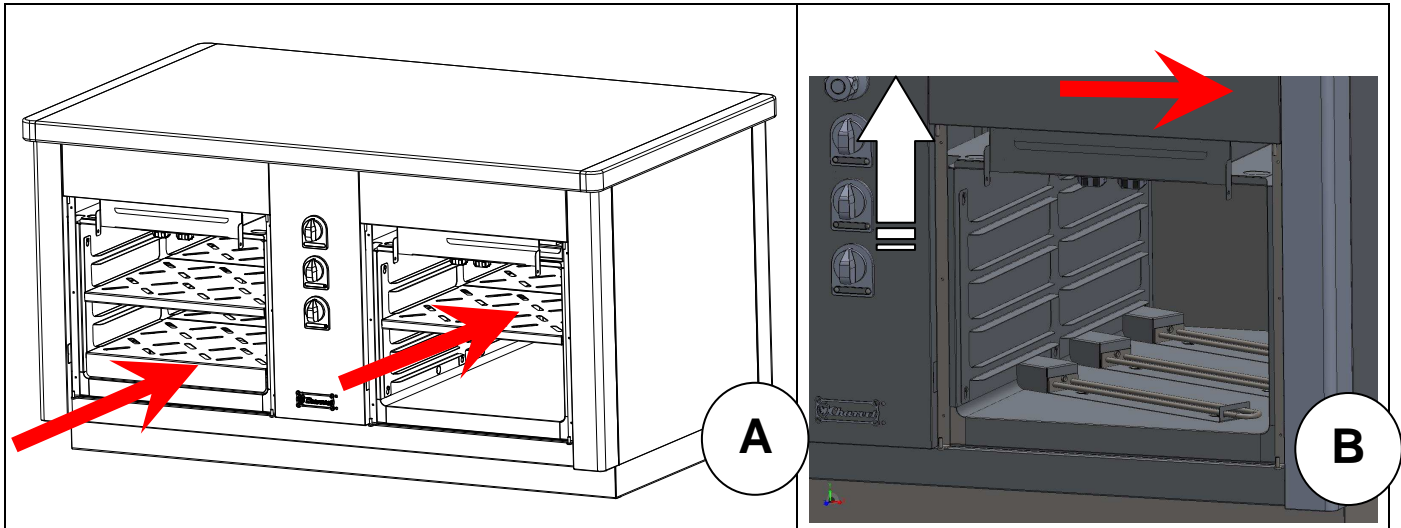

• Procedure

- Open the door and remove the shelves (A),
- Push them up before pulling them to the middle (B),
- Clean the parts in hot soapy water.

For best results, have your equipment serviced and cleaned on a regular basis by a qualified installer.

WARNING: Factory-sealed components must be serviced by neither installer nor user. Only a qualified electrician should replace the parts.

6. POSSIBLE CAUSES OF BREAKDOWN

Breakdown	Probable causes
Unsatisfactory heating	Clogging of the burners, injectors, etc.
	Incorrect gas pressure
	Incorrect grading of the injectors
	Clogging of the rear internal flue box (oven).
Incorrect oven temperature	Faulty thermostat
Incorrect ignition	Clogging of the pilot lights
	Clogging of the thermocouples
	Faulty thermocouples; incorrect flow of the pilot lights.
	Pilot lights badly positioned
	The control knobs are not pushed far enough
Faulty electric ignition	The spark plug is badly positioned.



Call for your installer to replace the faulty electric components in preparation for a next use.



The manufacturer and the installer cannot be held responsible if the user neglects to ask for assistance in case of breakdown.

7. DATA PLATE

TRANSFER below the information written on the DATA PLATE of your apparatus.

		CHARVET S.A.	
		38850 CHARAVINES	
Réf.	<input style="width: 100%;" type="text"/>		
Code:	<input style="width: 50%;" type="text"/>	Type:	<input style="width: 50%;" type="text"/>
N°FC:	<input style="width: 50%;" type="text"/>		<input style="width: 50%;" type="text"/>
N°OF:	<input style="width: 50%;" type="text"/>	Rep.	<input style="width: 50%;" type="text"/>
Cat.	<input style="width: 50%;" type="text"/>	<input style="width: 50%;" type="text"/>	
Gaz	<input style="width: 50%;" type="text"/>	<input style="width: 50%;" type="text"/>	<input style="width: 50%;" type="text"/>
P (mbar)	<input style="width: 50%;" type="text"/>	<input style="width: 50%;" type="text"/>	<input style="width: 50%;" type="text"/>
ΣQ_n (kW)	<input style="width: 50%;" type="text"/>	<input style="width: 50%;" type="text"/>	<input style="width: 50%;" type="text"/>
ΣV_n (m ³ /h)	<input style="width: 50%;" type="text"/>	<input style="width: 50%;" type="text"/>	<input style="width: 50%;" type="text"/>
ΣM_n (kg/h)	<input style="width: 50%;" type="text"/>	<input style="width: 50%;" type="text"/>	<input style="width: 50%;" type="text"/>
U	<input style="width: 50%;" type="text"/>	V	<input style="width: 50%;" type="text"/>
		Hz	<input style="width: 50%;" type="text"/>
P	<input style="width: 50%;" type="text"/>	kW	<input style="width: 50%;" type="text"/>
		<input style="width: 100%;" type="text"/>	
MADE IN FRANCE			

This will ease the communication between you and your supplier, and will help you with maintenance problems and spare parts.