



BOILING PANS - BOILING PANS - DIRECT HEATING

CYLINDRICAL TANK

Pro 900

Summary

Energy :

GAS

Code :

V03590

Designation :

GMF100CDL

Dimensions (W x D x H) :

850 x 900 x 900 mm

Power : 18 kW (gas)

Voltage/Electric p. : 1~230V+E / 0,180

Weight :

DEVICE DESCRIPTION

General description

Chassis :

Support frame in AISI 304 stainless steel, thickness 15 to 30/10, assembled by high intensity electric welds and lower rear release for passage of cables and supply tubes.

Top :

Top (frame) in AISI 304 stainless steel, 30/10 thick, with 55 mm front flanged edge and plywood.

Base :

Feet, height 200 mm, in AISI 304 stainless steel tube, diameter 60 mm with adjustable bases (0 / + 30).



Construction :

- . 100L boiler AISI304 stainless steel, thick. 20/10 - diameter 500 x depth 530 mm, AISI316L stainless steel tank bottom, sloped bottom, removable stainless steel strainer, centered drain valve.
- . AISI304 stainless steel cover th. 15/10 with spring-loaded hinge to keep it open and tube operating lever with insulating handle.
- . Heating by enamelled steel multi-ramp burner, with pilot burner and safety thermocouple, controlled by a gas thermostatic valve (combining the power supply, ignition, flame monitoring and regulation functions).
- . Electric ignition by spark train (manual ignition always possible).
- . Power : 18 kW gas + 0.01 kW in 1 / 230V + E.

Natural gas flow G20/20 :

Propane gas flow G31/37 :

OPTIONS

CODE







AISI 316 L tank - for saline and/or acid foods	V01433
Counter balanced lid - in all positions	Included
S/S rear panel fitted in factory - W : 415/840 x H : 645 mm	V01182
Double lid	Included
Mixer water tap CW/HW Ø 15x21 - swivel spout : 360°	V00561
Mixer water tap CW/HW Ø 15x21 - swivel spout : 180°	V01651
Hole cut to suit client's tap - tap supplied and fitted by client	V01292

ACCESSORIES

CODE

S/S clip on plinth panels - H : 170 mm for standard legs	V01187

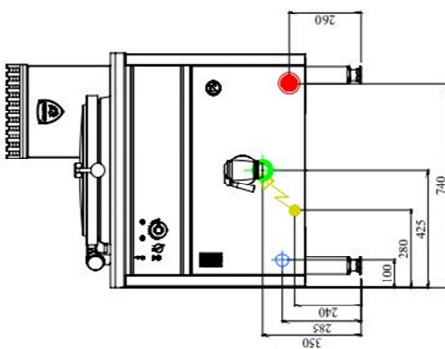
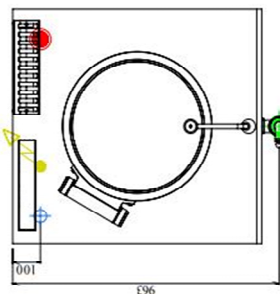
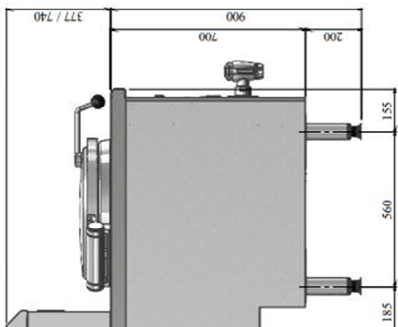
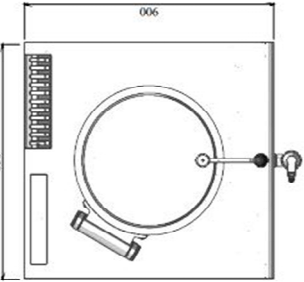
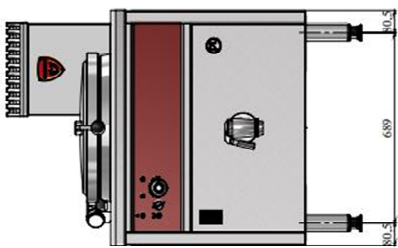
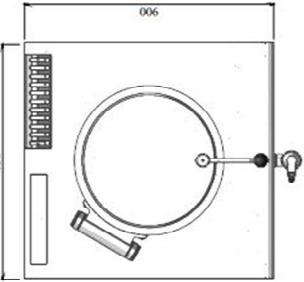

 <p>Connexion gaz Gas connection Gasanschluss Conexión gas</p>	 <p>Connexion électrique Electric connection Elektrische Verbindung Conexión eléctrica</p>	 <p>Options Optionen Ausstattungs Opciones</p>	 <p>Connexion eau froide Cold water connection Kaltwasseranschluss Conexión agua fría</p>	 <p>Connexion eau chaude Hot water connection Warmwasseranschluss Conexión agua caliente</p>	 <p>Connexion eau adoucie Softened water connection Wasserzulauf (gefiltertes wasser ≤ bars-ab. 7°GH) Conexión agua blanda ≤ 3 bars-ch...7°F</p>	 <p>Ecoulement eaux usées sewage outflow wasserablauf desagüe</p>	
							
				<p>Ø15x21 (1/2") 3~400V+N+PE - 4mm² Ø15x21 (1/2") Robinet de vidange 40x49</p>		<p>V03590 PRO900-G1-MF-100-EME/C</p>	



LES AUTHENTIQUES DE LA CUISSON

CHARVET

1170 rue principale - BP3 - 38850 Charavines - FRANCE

Tél: +33 (0)4 76 06 64 22 - info@charvet.fr

www.charvet.fr



YouTube

