











 <p>Connexion gaz Gasanschluss Gasanschluss Conexión gas</p>	 <p>Connexion électrique Electric connection Elektrische Verbindung Conexión eléctrica</p>	 <p>Options Optionen Aultraage Opciones</p>	 <p>Connexion eau froide Cold water connection Kaltwasseranschluss Conexión agua fría</p>	 <p>Connexion eau chaude Hot water connection Warmwasseranschluss Conexión agua caliente</p>	 <p>Connexion eau adoucie Softened water connection Wasserzulauf (gefiltertes wasser ≤ bars-ab. 7°GH) Conexión agua blanda ≤ 3 bars-ch...7°P</p>	 <p>Ecoulement eaux usées sewage outflow wasserablauf desagüe</p>
						
    		<p>1 ~ 230V + N + PE Ø2.5mm<sup>2</sup></p> <p>15X21 (1/2)</p>		<p>V03375 PRO900-1/2R-E1-BM-1/1-MULTI</p>		

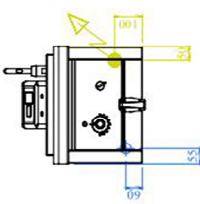
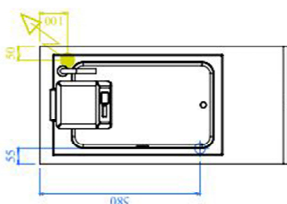
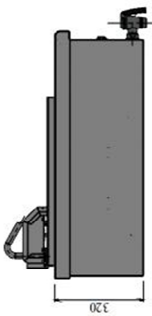
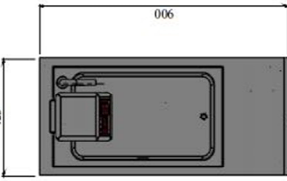

LES AUTHENTIQUES DE LA CUISSON

**CHARVET**

1170 rue principale - BP3 - 38850 Charavines - FRANCE

Tél: +33 (0)4 76 06 64 22 - info@charvet.fr

[www.charvet.fr](http://www.charvet.fr)



YouTube

