



BOILING PANS - WATER JACKETED - 150 L.

TILTING TANK

Pro 900

Summary

Energy :

GAS

Code :

V03242

Designation :

G1MBE150BME/C AERO

Dimensions (W x D x H) :

1275 x 900 x 900 mm

Power : 28 kW (gas)

Voltage/Electric p. : 1~230V+E / 0,180

Weight : 350 kg

DEVICE DESCRIPTION

General description

Chassis :

Support frame in AISI 304 stainless steel, thickness 15 to 30/10, assembled by high intensity.

Top :

Top (frame) in AISI 304 stainless steel, 30/10 thick, with 55 mm front flanged edge and plywood.

Base :

Feet, height 200 mm, in AISI 304 stainless steel tube, diameter 76 mm with adjustable bases (0 / + 30).

Cooking pot :

- . Cylindrical tank capacity 150 liters with plume:
 - . Boiled tank in 20/10 stainless steel, bottom of tank in 316L stainless steel and ferrule in AISI304 stainless steel, sloping domed bottom, large integrated spout
 - . Removable strainer in AISI304 stainless steel
 - . Chrome-plated bronze drain valve on the front with folding handle
 - . Internal ribs (mm): diameter: 595 x H: 550
 - . Lid in AISI304 stainless steel 15/10 thick with stainless steel spring hinges to keep it "open", and maneuvering lever in tube with insulating handle
 - . Drip grid included.
 - . Double envelope :
 - . External tank in AISI304 stainless steel 30/10 thickness
 - . Safety group (pressure gauge and safety valve)
- Heating :**
- . Burner in stainless steel tube (x2) total power 28 kW.
 - . Control by gas valve ensuring power supply, ignition (spark train) and flame monitoring.
 - . Regulation by thermostat.
 - . "Burner cut-off" safety when the tank is tilted; immediate restart when the latter is again in position.



Natural gas flow G20/20 :

2,96

Propane gas flow G31/37 :

2,18

OPTIONS

CODE

AISI 316 L tank for saline and/or acid foods	V01433
Automatic leveling - 1~230V+E / 0,022 kW	Included
Sequential regulation 1-230 V + E / 0.008 kW	Included
Counter balanced lid in all positions	Included
S/S rear panel fitted in factory W : 415/840 x H : 645 mm	V02977
Pan tilt safety cut-out included - stop heating when tilting	Included
Doubled lid	Included
Mixer water tap CW/HW Ø 15x21 - swivel spout : 360°	Included
Mixer water tap CW/HW Ø 20x27 - swivel spout : 360°	Included

ACCESSORIES

CODE



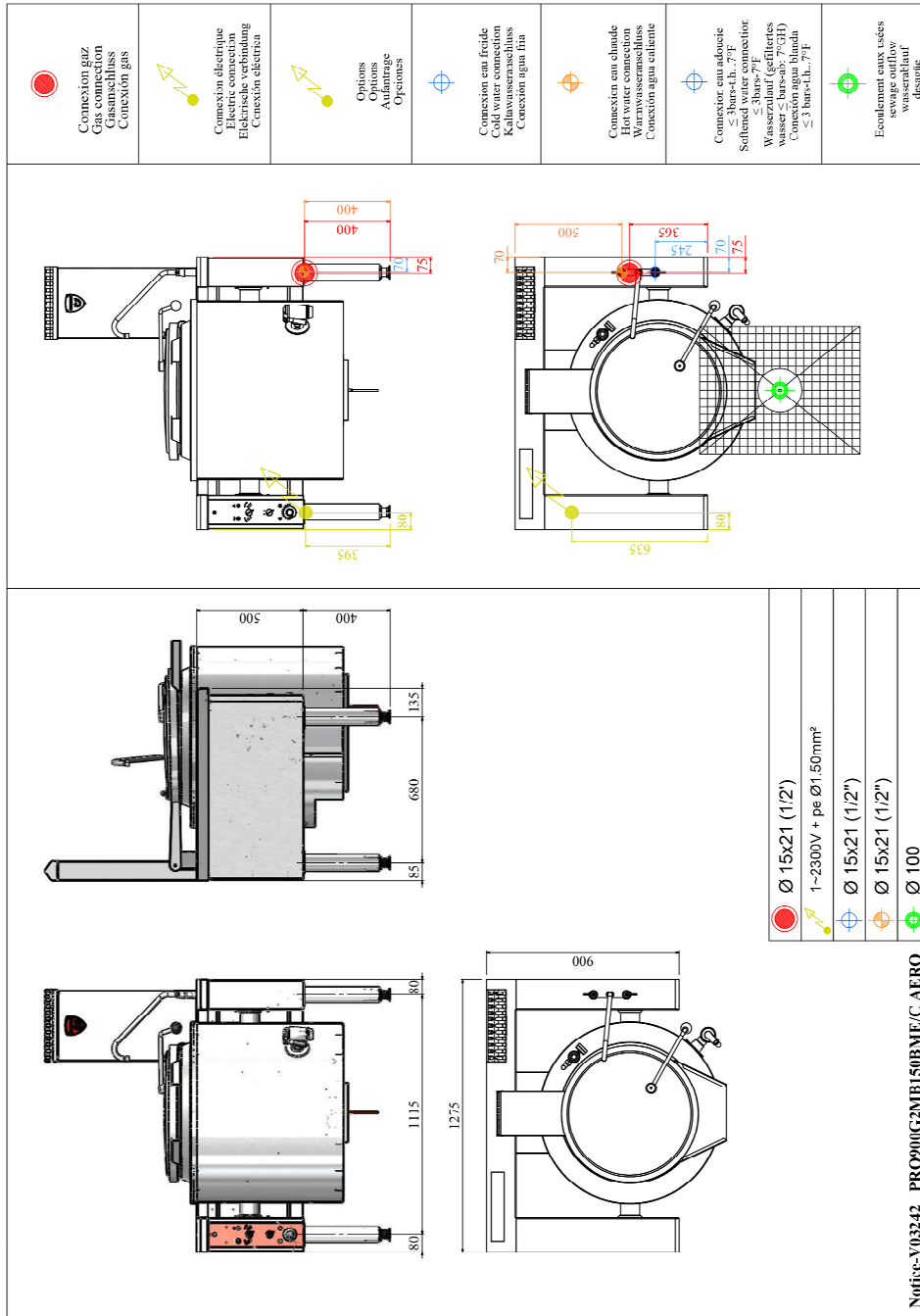

LES AUTHENTIQUES DE LA CUISSON

CHARVET

1170 rue principale - BP3 - 38850 Charavines - FRANCE

Tél: +33 (0)4 76 06 64 22 - info@charvet.fr

www.charvet.fr

