



ACCESSORIES FOR FRYERS - OIL FILTRATION

OIL FILTRATION UNIT

Pro 900

Summary

Energy :
NEUTRAL

Code :
V01819

Designation :
1/2SILOFRIT

Dimensions (W x D x H) :
425 x 900 x 900 mm
Power :
Voltage/Electric p. :
Weight :

DEVICE DESCRIPTION

General description

Chassis :

Carrying frame in 18-10 stainless steel, thickness 15 to 30/10, assembled by electrical welds.

Top :

Top (frame) in 18-10 stainless steel, thickness 30/10.



Above :

. Neutral top in 18-10 stainless steel to fix, with hopper

Below:

. 18-10 stainless steel guide rails

Endowment:

. 1 reception trolley under silo;

. Frame in 25x25 mm stainless steel tube;

. 18-10 stainless steel runners with 2 GN1 / 1 levels with clearance on the front face

. Cylindrical stainless steel handle

. 4 swivel wheels without brake

. 2 full stainless steel containers GN1 / 1 x 150 mm

Natural gas flow G20/20 :

Propane gas flow G31/37 :

OPTIONS

CODE

S/S rear panel fitted in factory W : 415 x H : 645 mm

V01181

ACCESSORIES

CODE



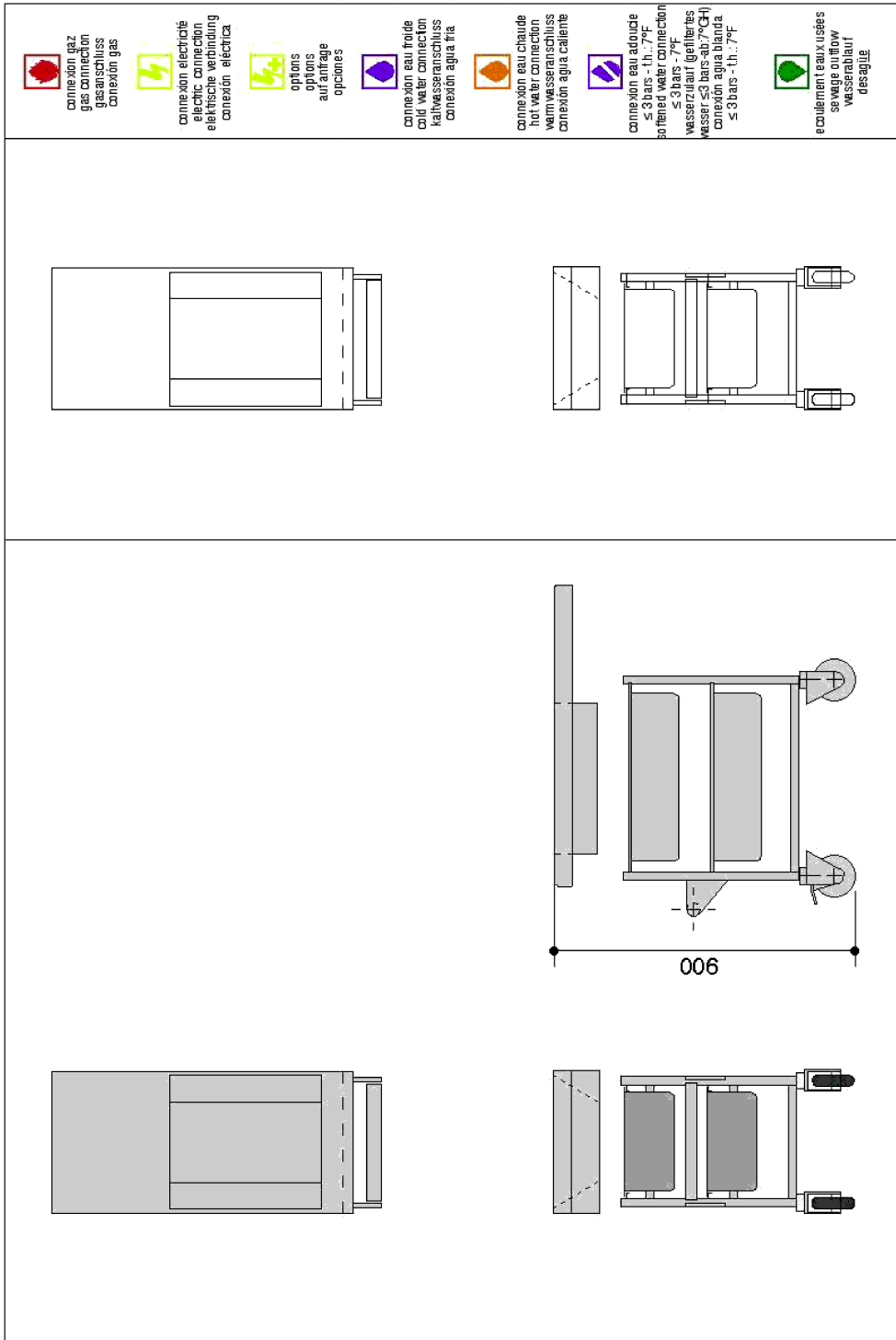

LES AUTHENTIQUES DE LA CUISSON

CHARVET

1170 rue principale - BP3 - 38850 Charavines - FRANCE

Tél: +33 (0)4 76 06 64 22 - info@charvet.fr

www.charvet.fr

