



MODULES W. 525 MM - 2 OPEN BURNERS

OPEN BASE GN 1/1

EXTEND Concept

Summary

Energy : GAS	Code : GMC0084	Designation : NA	Dimensions (W x P x H) : 525 x 1000 x 900 mm Power : 16 kW (gas) Voltage/Electric p. : 1-230V+E/ 0,01 Weight :
-------------------------------	---------------------------------	-----------------------------------	---

DEVICE DESCRIPTION

General description

Chassis :

. One-piece seam welded stainless steel chassis 3 mm thick duct at the back AISI 430 TI (F17 titan).

Top :

. AISI 430 Ti stainless steel top 3 mm thick (F17 tan) with a 55mm high edge and return to underside.

General :

- . AISI304 side and front panels 1.2mm thick polished in line, no visible screws.
- . Bright polished stainless steel (AISI304) corner column 1.2mm thick.
- . Chrome coated dial indicator and knob.
- . Mechanical assembly of the frames behind removable panels.



Top :

- . 2 open burners under cast iron grids 420 x 300 mm space 100 mm between grids.
- Bare lights :
- . 8 kW "I-system" double crown burner with central flames, with electric ignition, consisting of a solid brass skin and a cast iron body reinforced with an an 3 corrosion surface treatment.
- . Overflow protected pilot light and thermocouple safety.
- . Driven by "slow down, full fire" valves.
- . Removable retention tank in AISI 304 stainless steel, water tank with manual valve common to 2 burners, overflow drain removable.
- . Cast iron grid.
- Basement :
- . GN 1/1 open base, radiated corners in low part and removable ladders.

Natural gas flow G20/20 :
Propane gas flow G31/37 :

OPTIONS	CODE
Crossing GN 1/1 cupboard	GMC0149
GN 1/1 pass-through oven	GMC0147
1 electrical outlet 1-230V	GMC0117
2 electrical outlets 1-230V	GMC0118
Electric ignition	Included

ACCESSORIES	CODE
Center suite end kit	GMC0075
Suite End Wall Kit	GMC0097
Link kit between modules	GMC0074



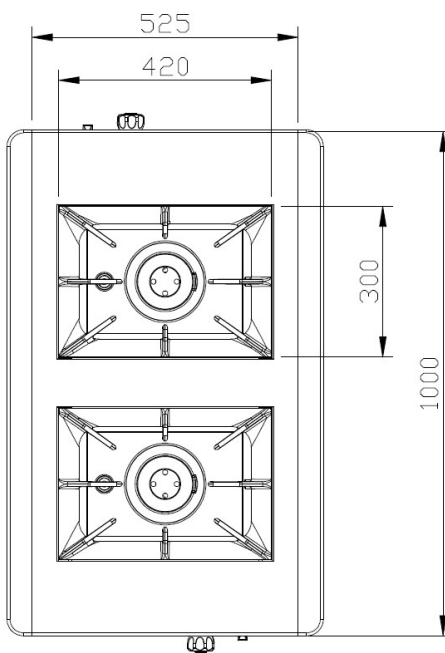
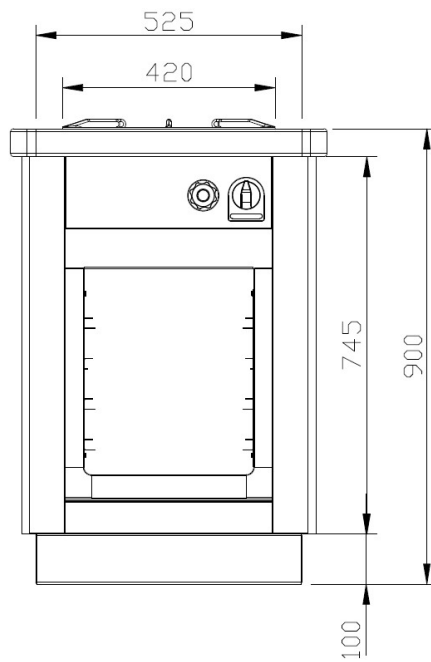

LES AUTHENTIQUES DE LA CUISSON

CHARVET

1170 rue principale - BP3 - 38850 Charavines - FRANCE

Tél: +33 (0)4 76 06 64 22 - info@charvet.fr

www.charvet.fr



YouTube

